

harman/kardon

AVR645

A/V DOLBY DIGITAL RECEIVER

SERVICE MANUAL



CONTENTS

ESD WARNING.....	2	PROCESSOR RESET.....	28
LEAKAGE TESTING.....	3	UNIT EXPLODED VIEW.....	29
BASIC SPECIFICATIONS.....	4	EXPLODED VIEW PARTS LIST.....	30
PACKAGE.....	5	IDLE CURRENT ADJUST.....	33
PACKAGE PARTS LIST.....	6	BLOCK DIAGRAM(S).....	36
FRONT PANEL CONTROLS.....	7	CIRCUIT DESCRIPTION.....	37
REAR PANEL CONNECTIONS.....	10	SEMICONDUCTOR PINOUTS.....	38
REMOTE CONTROL FUNCTIONS.....	13	PCB DRAWINGS.....	88
INSTALLATION/CONNECTIONS.....	17	ELECTRICAL PARTS LIST.....	100
OPERATION.....	20	SCHEMATICS.....	124
TROUBLESHOOTING GUIDE.....	28	WIRING DIAGRAM.....	139

harman/kardon, Inc.
250 Crossways Park Dr.
Woodbury, New York 11797

Rev0 – 11/2006

ELECTROSTATICALLY SENSITIVE (ES) DEVICES

Some semiconductor (solid state) devices can be damaged easily by static electricity. Such components commonly are called Electrostatically Sensitive (ES) Devices. Examples of typical ES devices are integrated circuits and some field effect transistors and semiconductor "chip" components.

The following techniques should be used to help reduce the incidence of component damage caused by static electricity.



1. Immediately before handling any semiconductor component or semiconductor-equipped assembly, drain off any electrostatic charge on your body by touching a known earth ground. Alternatively, obtain and wear a commercially available discharging wrist strap device, which should be removed for potential shock reasons prior to applying power to the unit under test.
2. After removing an electrical assembly equipped with ES devices, place the assembly on a conductive surface such as aluminum foil, to prevent electrostatic charge build-up or exposure of the assembly.
3. Use only a grounded-tip soldering iron to solder or unsolder ES devices.
4. Use only an anti-static solder removal device. Some solder removal devices not classified as "anti-static" can generate electrical charges sufficient to damage ES devices.
5. Do not use freon-propelled chemicals. These can generate electrical charge sufficient to damage ES devices.
6. Do not remove a replacement ES device from its protective package until immediately before you are ready to install it. (Most replacement ES devices are packaged with leads electrically shorted together by conductive foam, aluminum foil or comparable conductive material.)
7. Immediately before removing the protective material from the leads of a replacement ES device, touch the protective material to the chassis or circuit assembly into which the device will be installed.

CAUTION : Be sure no power is applied to the chassis or circuit, and observe all other safety precautions.

8. Minimize bodily motions when handling unpackaged replacement ES devices. (Otherwise harmless motion such as the brushing together of your clothes fabric or the lifting of your foot from a carpeted floor can generate static electricity sufficient to damage an ES devices.

PRODUCT SAFETY NOTICE

Each precaution in this manual should be followed during servicing.

Components identified with the IEC symbol  in the parts list are special significance to safety. When replacing a component identified with , use only the replacement parts designated, or parts with the same ratings or resistance, wattage, or voltage that are designated in the parts list in this manual. Leakage-current or resistance measurements must be made to determine that exposed parts are acceptably insulated from the supply circuit before returning the product to the customer.

SAFETY PRECAUTIONS

The following check should be performed for the continued protection of the customer and service technician.

LEAKAGE CURRENT CHECK

Measure leakage current to a known earth ground (water pipe, conduit, etc.) by connecting a leakage current tester between the earth ground and all exposed metal parts of the appliance (input/output terminals, screwheads, metal overlays, control shaft, etc.). Plug the AC line cord of the appliance directly into a 120V AC 60Hz outlet and turn the AC power switch on. Any current measured must not exceed 0.5mA.

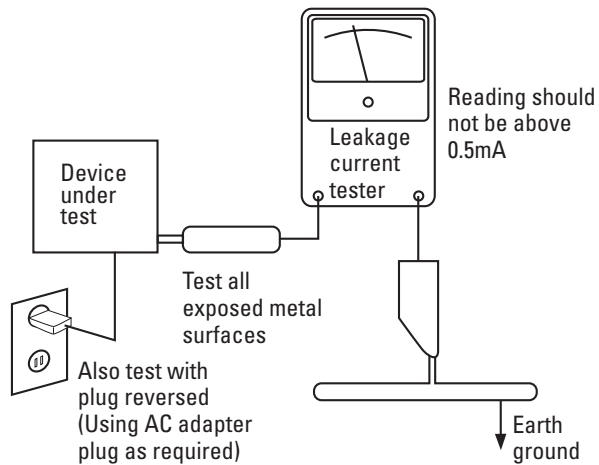

AC Leakage Test

ANY MEASUREMENTS NOT WITHIN THE LIMITS OUTLINED ABOVE ARE INDICATIVE OF A POTENTIAL SHOCK HAZARD AND MUST BE CORRECTED BEFORE RETURNING THE APPLIANCE TO THE CUSTOMER.

AVR 645 TECHNICAL SPECIFICATIONS

Audio Section

Stereo Mode

Continuous Average Power (FTC)

90 Watts per channel, 20Hz–20kHz,
@ <0.07% THD, both channels driven into 8 ohms

Seven-Channel Surround Modes

Power per Individual Channel

Front L&R channels:
75 Watts per channel
@ <0.07% THD, 20Hz–20kHz into 8 ohms

Center channel:
75 Watts @ <0.07% THD, 20Hz–20kHz into 8 ohms

Surround (L & R Side, L & R back) channels:
75 Watts per channel
@ <0.07% THD, 20Hz–20kHz into 8 ohms

Input Sensitivity/Impedance

Linear (High-Level) 200mV/47k ohms

Signal-to-Noise Ratio (IHF-A)

100dB

Surround System Adjacent Channel Separation

Dolby Pro Logic 40dB

Dolby Digital 55dB

DTS 55dB

Frequency Response

@ 1W (+0dB, -3dB) 10Hz – 130kHz

High Instantaneous

Current Capability (HCC)

±50 Amps

Transient Intermodulation

Distortion (TIM)

Unmeasurable

Slew Rate

40V/μsec

FM Tuner Section

Frequency Range 87.5–108.0MHz

Usable Sensitivity IHF 1.3μV/13.2dB

Signal-to-Noise Ratio Mono/Stereo 70/68dB

Distortion Mono/Stereo 0.2/0.3%

Stereo Separation 40dB @ 1kHz

Selectivity ±400kHz, 70dB

Image Rejection 80dB

IF Rejection 90dB

Supplied Accessories

The AVR 645 is supplied with the following accessory items. If any item is missing, please contact Harman Kardon customer service at www.harmankardon.com.

- Six AAA batteries
- System remote control
- ZR 10 remote control
- **IIIExSet/EQ** microphone
- Extender rod for microphone
- AM loop antenna
- FM wire antenna
- AC power cord

AM Tuner Section

Frequency Range 520–1720kHz
Signal-to-Noise Ratio 45dB
Usable Sensitivity Loop 500μV
Distortion 1kHz, 50% Mod 0.8%
Selectivity ±10kHz, 30dB

Video Section

Television Format NTSC
Input Level/Impedance 1V p-p/75 ohms
Output Level/Impedance 1V p-p/75 ohms
Video Frequency Response (Composite and S-Video) 10Hz–8MHz (-3dB)
Video Frequency Response (Component Video) 10Hz–100MHz (-3dB)
HDMI Version 1.1

General

Power Requirement AC 120V/60Hz
Power Consumption 120W at Power On, idle; 1,272W at rated power output (7 channels driven)

Dimensions

Dimensions	Product	Shipping
Width	17-5/16 inches (440mm)	20-1/16 inches (510mm)
Height	6-1/2 inches (165mm)	10 inches (254mm)
Depth	17-1/16 inches (435mm)	22-3/16 inches (565mm)
Weight	41 lb (18.6kg)	48 lb (21.8kg)

Depth measurement includes knobs, buttons and terminal connections.

Height measurement includes feet and chassis.

All features and specifications are subject to change without notice.

Harman Kardon, Harman International and Logic 7 are registered trademarks of Harman International Industries, Incorporated.

IIIExSet/EQ and **IIIExSet/EQ** are trademarks of Harman International Industries, Incorporated.

Dolby, Pro Logic and the Double-D symbol are registered trademarks of Dolby Laboratories. Manufactured under license from Dolby Laboratories.

DTS, DTS Surround, DTS-ES, DTS 96/24 and DTS Neo:6 are registered trademarks of DTS, Inc.

A-BUS and A-BUS/*READY* are registered trademarks of Leisure Tech Electronics Pty Ltd Australia.

SACD is a trademark of Sony Corporation.

iPod and iTunes are registered trademarks of Apple Computer, Inc.

HD-DVD is a trademark of the DVD Format/Logo Licensing Corporation (DVD FLLC).

HDMI, the HDMI logo and High-Definition Multimedia Interface are trademarks or registered trademarks of HDMI Licensing, LLC.

Microsoft, Windows and Windows Media are registered trademarks of Microsoft Corporation in the United States and other countries.

XM-Ready is a registered trademark of XM Satellite Radio, Inc.

Faroudja is a registered trademark of Faoudja, a division of Genisys Microchop.

RealPlayer is a registered trademark of RealNetworks.

Winamp is a registered trademark of America Online, Inc.

TiVo is a registered trademark of TiVo Inc.

RePlayTV is a registered trademark of Digital Networks North America, Inc.

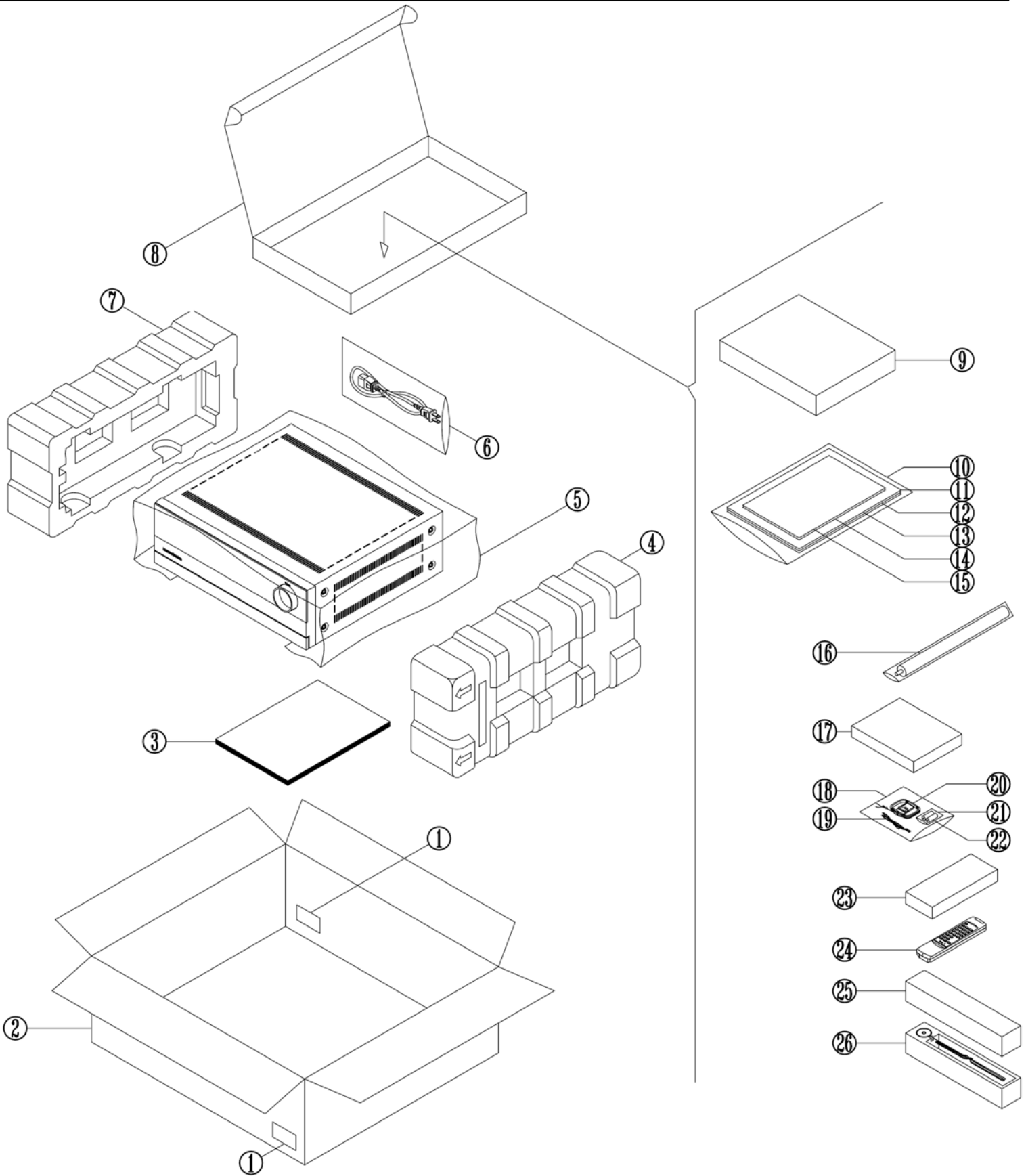

PACKING PARTS LIST FOLLOWING PAGE

AVR645 US/EU Packing Part List			
Item #	Part Number	Description	
1		LABEL BARCODE AVR TF PRINT	
2	ZKD2904HA01-R	BOX CARTON AVR645US	US
	ZKD3004HA00-R	BOX CARTON AVR645 EU	EU
3	ZKD2901HA00-R	OWNER'S MANUAL AVR645US	US
	ZKD3001HA00-R	OWNER'S MANUAL AVR645 EU	EU
4	ZQD1201HAWH-R	CUSHION POLY EPS RIGHT AVR	
5		FILM SHEET PE 920 X 1000	
6	H03-WAD022000BK-R	POWER CORD WR002 H05VV-F 0.75MMSQ 2G BLACK	
7	ZQD1202HAWH-R	CUSHION POLY EPS LEFT AVR	
8		AVR TOTAL ACCESSORY BOX	
9		REMOCON W/ ACCESSORY BOX AVR	
10		BAG PE 330 X245 T0.05	
11	ZKD2916HB00-R	QUICK SETUP GUIDE AVR645US	
12		LABEL SAFETY LEAFLET	
13	ZKC1113HA00-R	CARD WARRANTY	
14	ZKD1263HA00-R	BROCHURE AVR US	
15	ZKC1263HA00-R	INSERT RS232 NOTE PAPER	
16	H03-ZPD1212INBK-R	MICROPHONE ASSY EXTENSION PIECE	
17		INSERT RS232 NOTE PAPER	
18		BAG PE 160X180MM	
19	H03-WAB01200203-R	FM ANTENNA WIRE 75 T15011N-1	US
	H03-WAD01200303-R	ANTENNA WIRE 75 OHM WIRE T15011F-1	EU
20	H03-ATALF039ABK-R	AM ANTENNA WIRE ANTENNA LOOP-300	
21		POLYBAG BATTERY	
22		BATTERY ALKALINE 1.5V AAA	
23		BOX, ZONE II REMOTE CONTROL	
24	H03-RYD2702HA00-R	REMOCON ZONE II AVR	US
	H03-RYD2702HA01-R	REMOCON ZONE II AVREU	EU
25		BOX MIC	
26	H03-MCD12TWBKNN-R	AVR635 MICROPHONE ASSY	

FRONT - PANEL CONTROLS

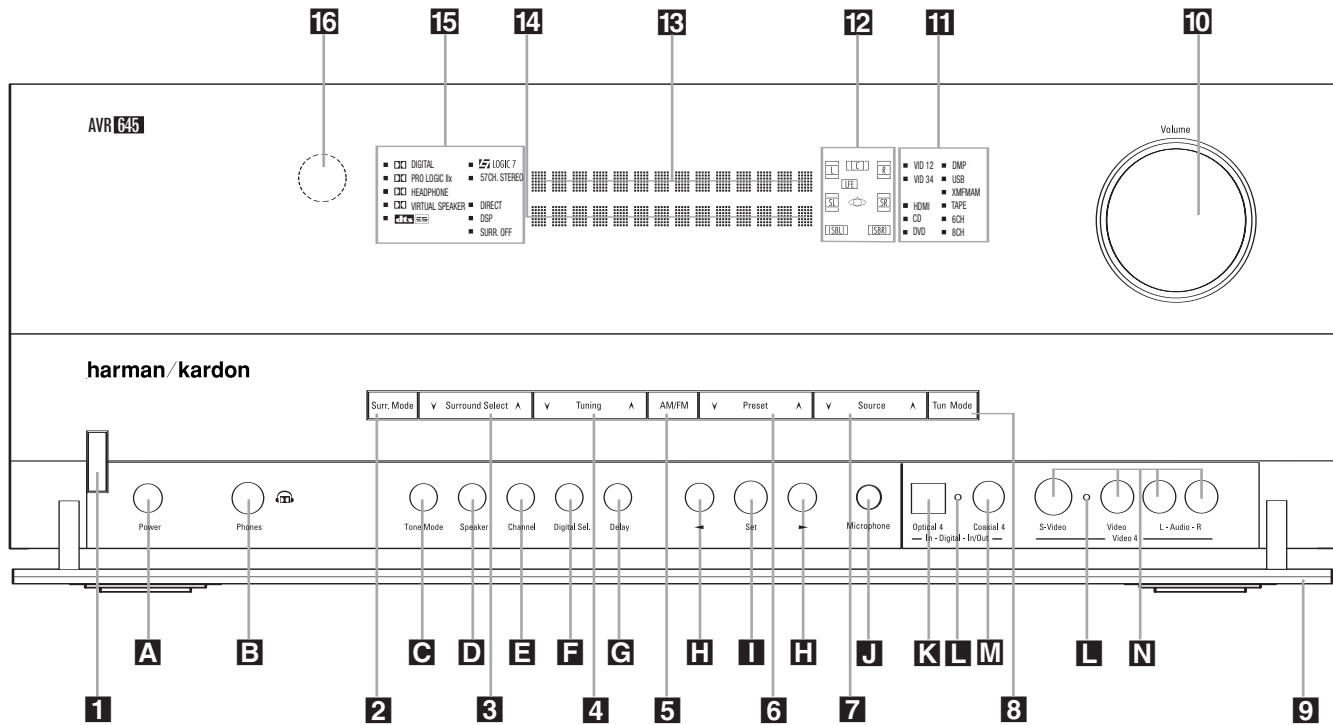

NOTE: To make it easier to follow the instructions that refer to this illustration, a larger copy may be downloaded from the Product Support section for this product at www.harmankardon.com.

The following controls and indicators are available on the AVR 645's front panel:

- 1** Standby/On Switch
- 2** Surround Mode Group Selector
- 3** Surround Mode Selector
- 4** Tuning Selector
- 5** Tuner Band Selector
- 6** Preset Station Selector
- 7** Input Source Selector
- 8** Tuning Mode Selector
- 9** Front-Panel Door
- 10** Volume Control
- 11** Input Indicators
- 12** Speaker/Channel Input Indicators
- 13** Upper Display Line
- 14** Lower Display Line
- 15** Surround Mode Indicators
- 16** Remote Sensor Window

The following controls and jacks are located behind the front-panel door. To open the door, place the edge of a finger on the left or right edge of the panel and gently swing the door down toward you.

- A** Main Power Switch
- B** Headphone Jack
- C** Tone Mode Button
- D** Speaker Selector Button
- E** Channel Adjust Selector
- F** Digital Input Selector
- G** Delay Adjust Selector
- H** ◀▶ Buttons
- I** Set Button
- J** EzSet/EQ Microphone Jack
- K** Optical 4 Digital Input
- L** Input/Output Status Indicators
- M** Coaxial 4 Digital Jack
- N** Video 4 Input/Output Jacks

1 Standby/On Switch: When the **Main Power Switch A** is "ON," press this button to turn on the AVR 645; press it again to turn the unit off. Note that the illumination surrounding the switch will turn blue when the unit is on, or in the Multiroom mode.

2 Surround Mode Group Selector: Press this button to select the top-level group of surround modes. Each press of the button will select one of the surround mode categories. Once the button is pressed so

that the name of the desired surround mode category appears in the on-screen display and in the **Lower Display Line 14**, press the **Surround Mode Selector 3** to cycle through the individual modes available. For example, press this button to select Dolby by modes, and then press the **Surround Mode Selector 3** to choose from the various mode options.

3 Surround Mode Selector: Press this button to select from among the available surround mode

options for the surround mode category selected. The specific modes will vary based on the number of speakers available, the surround mode category and whether the input source is digital or analog. For example, press the **Surround Mode Group Selector 2** to select a category such as Dolby or Logic 7, and then press this button to see the specific mode choices that are available. For more information on mode selection, see pages 37 and 60.

FRONT - PANEL CONTROLS

4 Tuning Selector: Press the left side of the button to tune lower-frequency stations and the right side of the button to tune higher-frequency stations. When the tuner is in the **MANUAL/MONO** mode, each tap of the Selector will increase or decrease the frequency by one increment. When the tuner receives a signal strong enough for adequate reception, **MANUAL TUNED** will appear in the **Lower Display Line 14** and in the on-screen display. When the tuner is in the **AUTO/STEREO** mode, press the button once, and the tuner will scan for a station with acceptable signal strength. When the frequency scan will stop and the **Lower Display Line 14** and the on-screen display will indicate **AUTO TUNED**. When an FM stereo station is tuned, the display will read **AUTO ST TUNED**. See page 41 for more information on using the tuner. When an XM-Ready module is connected and activated, and when there is sufficient signal strength for the XM system to operate, pressing this button will change the XM Radio channel.

5 Tuner Band Selector: Pressing this button will automatically switch the AVR 645 to the Tuner mode. Pressing it again will select the AM or FM frequency band, or XM Radio. (See page 41 for more information on the tuner.)

6 Preset Station Selector: Press this button to scroll up or down through the list of stations that have been entered into the preset memory. (See page 41 for more information on tuner programming.)

7 Input Source Selector: Press this button to change the input by scrolling up or down through the list of input sources.

8 Tuning Mode Selector: Press this button to select Auto or Manual tuning. When the button is pressed so that **AUTO/STEREO** appears in the **Upper Display Line 13**, the tuner will search for the next station with an acceptable signal when the **Tuning Selector 4 23 P** is pressed. When the button is pressed so that **MANUAL/MONO** appears in the **Upper Display Line 13**, each press of the **Tuning Selector 4 23 P** will increase the frequency. (See page 41 for more information on using the tuner.)

This button may also be used to switch between Stereo and Mono modes for FM radio reception. When weak reception is encountered, select the Manual/Mono tuning mode. Press and hold again to switch back to Stereo mode. (See pages 41 for more information on using the tuner.)

When an optional XM Connect & Play module is connected and activated, and when there is sufficient signal strength for the XM system to operate, this button has a different set of functions than when traditional AM or FM radio is in use. See page 41 for more information on XM Radio operation.

9 Front-Panel Door: To open the door so that the front-panel jacks and controls behind this door may be accessed, gently pull the door down and toward you, using either upper corner of the door.

10 Volume Control: Turn this knob clockwise to increase the volume, counterclockwise to decrease the volume. If the AVR 645 is muted, adjusting the volume control will automatically release the unit from the silenced condition.

11 Input Indicators: One of these indicators will light to identify the currently selected input. Note that the entire list will light briefly each time the unit is turned on, as a test.

12 Speaker/Channel Input Indicators: These indicators are multipurpose, indicating both the speaker type selected for each channel and the incoming data-signal configuration. The left, center, right, right surround and left surround speaker indicators are composed of three boxes, while the subwoofer is indicated by one box. The center box lights when a "small" speaker is selected, and the two outer boxes light when "large" speakers are selected. When none of the boxes are lit for the center, surround or subwoofer channels, no speaker has been assigned that position. The letters inside each box display the active input channels. For standard analog inputs, only the L and R will light, indicating a stereo input. For a digital source, the indicators will light to display the channels being received at the digital input. When the letters flash, the digital input has been interrupted. (See page 40 for more information on the Channel Indicators.)

13 Upper Display Line: Depending on the unit's status, a variety of messages will appear here. In normal operation, this line will show the current input source and identify whether an analog or digital input is in use. When the tuner is selected as the input, this line will identify the station as AM or FM and show the frequency and preset number, if any.

When an XM Connect & Play module is connected and activated, and when there is sufficient signal strength for the XM system to operate, the XM channel number and signal strength will appear here.

14 Lower Display Line: Depending on the unit's status, a variety of messages will appear here. In normal operation, the current surround mode will appear on this line. When an XM-Ready module is connected and activated, and when there is sufficient signal strength for the XM system to operate, a variety of messages and information, including the XM channel title name, the current artist and track title, the XM Radio channel category and, when available, local traffic and weather information, will appear here.

15 Surround Mode Indicators: One of these indicators will light to show the surround mode in use. Depending on the specific combination of input sources and surround mode selected, more than one indicator may light. (See page 38 for more information.)

16 Remote Sensor Window: The sensor behind this window receives infrared signals from the remote control. Aim the remote control at this area, and do not block or cover it unless an external remote sensor is installed.

FRONT-PANEL CONTROLS

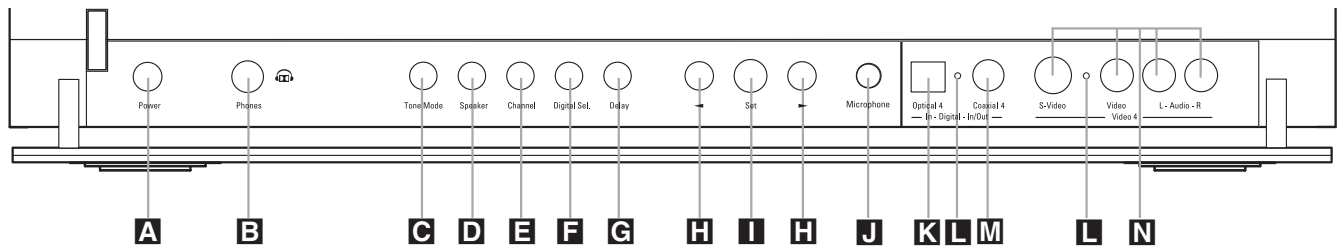

The following controls and jacks are located behind the front-panel door. To open the door, place the edge of a finger on the left or right edge of the panel and gently swing the door down toward you.

A Main Power Switch: Press this switch to apply power to the AVR 645. When the switch is pressed in, the unit is placed in a Standby mode, as indicated by the amber illumination surrounding the **Standby/On Switch 1**. This button **MUST** be pressed in to operate the unit. To turn the unit off and prevent the use of the remote control, this switch should be pressed until it pops out from the front panel so that the word "OFF" may be read at the top of the switch.

NOTE: This switch is normally left in the "ON" position.

B Headphone Jack: This jack may be used to listen to the AVR 645's output through a pair of headphones. Be certain that the headphones have a standard 1/4" stereo phone plug, or that you use an adapter, as needed, to convert the plug on your headphones to the 1/4" jack used on the AVR. When the headphone jack is in use, the main room speakers will automatically be turned off and the unit will output a standard stereo signal. You may also use the Dolby Headphone mode for an enhanced listening experience.

C Tone Mode Button: This button controls the tone mode settings, enabling adjustment of the bass and treble boost/cut. You may also use it to take the tone controls out of the signal path completely for "flat" response. The first press of the button displays a **TONE MODE** message in the **Lower Display Line 14** and in the on-screen display. To take the controls out of the signal path, press either of the **Navigation Buttons H** until the display reads **TONE OUT**. To change the bass or treble settings, press the button again until the desired option appears in the **Lower Display Line 14** and in the on-screen display and then press either of the **Navigation Buttons H** to enter the desired boost or cut setting. See page 37 for more information on the tone controls.

D Speaker Selector Button: Press this button to begin the process of manually configuring the AVR 645 for the type of speakers it is being used with. For complete information on configuring the speaker settings, see page 30.

E Channel Adjust Selector: Press the button to begin the process of manually adjusting the channel level outputs using the source currently playing through your AVR. For complete information on adjusting the channel output level, see page 33.

F Digital Input Selector: Press this button to begin the process of selecting a digital source for use with the currently selected input. Once the button has been pressed, use the **Navigation Buttons H** to choose the desired input and then press the **Set Button I** to enter the setting into the unit's memory. See page 37 for more information on digital audio.

G Delay Adjust Selector: Press this button to begin the process of adjusting the delay settings. See page 32 for more information on delay adjustments.

H Navigation Buttons: When making system configuration changes using the front-panel controls, press these buttons to scroll through the available choices for the option being adjusted.

I Set Button: When making system configuration changes using the front-panel controls, press this button to enter a setting into the unit's memory.

J EzSet/EQ Microphone Jack: Before starting the EzSet/EQ automated setup process, plug the microphone into this jack. The microphone does not need to be plugged in at other times.

K Optical 4 Digital Input: Connect the optical digital output of an audio or video product to this jack.

L Input/Output Status Indicators: These LED indicators will normally light green to show that the front-panel **Coaxial 4 Digital Jack M** and **Video 4 Input/Output Jacks N** are operating as inputs. When these jacks are configured for use as outputs, the appropriate indicator will turn red to show that the jack may be used as an output for recording. (See page 24 for more information on configuring the front-panel jacks as outputs, rather than inputs.)

M Coaxial 4 Digital Jack: Connect the coaxial digital input or output for a digital audio product such as a portable audio player or video game to this jack. The jack is normally an input, but may be switched to an output for recording, using the menu system. See page 24 for more information.

N Video 4 Input/Output Jacks: These audio/video jacks may be used as either inputs or outputs for temporary connection to video games or portable audio/video products such as camcorders and portable audio players. (See page 24 for more information on switching one of these jacks between an input and output.)

REAR-PANEL CONNECTIONS

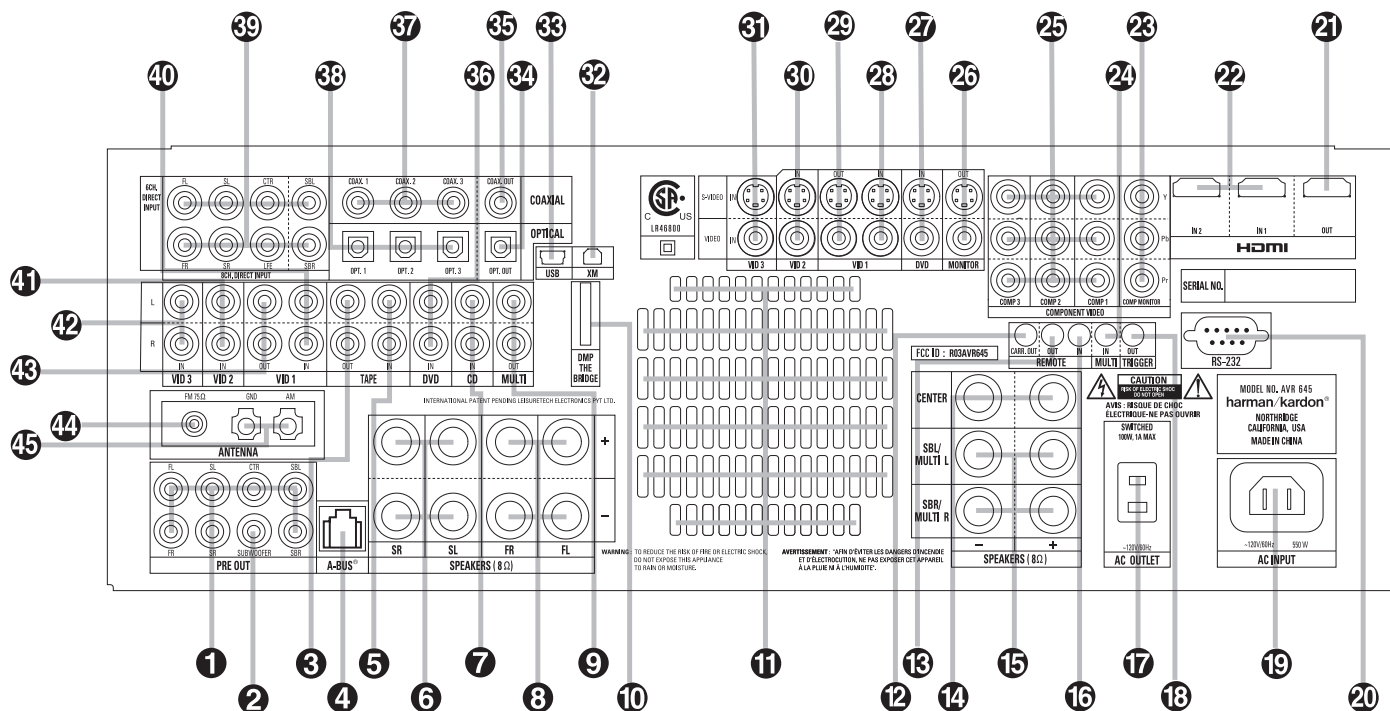

NOTE: To make it easier to follow the instructions that refer to this illustration, a larger copy may be downloaded from the Product Support section for this product at www.harmankardon.com.

- | | | |
|---|---|---|
| <ul style="list-style-type: none"> 1 Preamp Outputs 2 Subwoofer Output 3 Tape Outputs 4 A-BUS Connector 5 Tape Inputs 6 Surround Speaker Outputs 7 CD Audio Input 8 Front Speaker Outputs 9 Multiroom Audio Outputs 10 The Bridge™ Digital Media Player (DMP) Input 11 Fan Vents 12 Full Carrier IR Output 13 IR Output 14 Center Channel Speaker Outputs 15 Surround Back/Multiroom Speaker Outputs 16 IR Input | <ul style="list-style-type: none"> 17 Switched AC Accessory Outlet 18 Trigger Output 19 AC Power Cord Socket 20 RS-232 Port 21 HDMI Output 22 HDMI Inputs 23 Component Video Monitor Outputs 24 Multiroom IR Input 25 Component Video Inputs 26 Video Monitor Outputs 27 DVD Video Inputs 28 Video 1 Video Inputs 29 Video 1 Video Outputs 30 Video 2 Video Inputs 31 Video 3 Video Inputs 32 XM-Ready Module Input | <ul style="list-style-type: none"> 33 USB Connector 34 Optical Digital Audio Output 35 Coaxial Digital Audio Output 36 DVD Audio Inputs 37 Coaxial Digital Audio Inputs 38 Optical Digital Audio Inputs 39 8-Channel Direct Inputs 40 Video 1 Audio Inputs 41 Video 2 Audio Inputs 42 Video 3 Audio Inputs 43 Video 1 Audio Outputs 44 FM Antenna Jack 45 AM Antenna Connections |
|---|---|---|

<p>NOTE: To assist in making the correct connections for multichannel input, output and speaker connections, all connection jacks and terminals are color-coded as follows:</p>		
Front Left:	White	Surround Left: Blue
Front Right:	Red	Surround Right: Gray
Center:	Green	Surround Back Left: Brown
		Surround Back Right: Tan
		Subwoofer: Purple
		Coaxial Digital Audio: Orange
		Composite Video: Yellow
		Component Video "Y": Green
		Component Video "Pr": Red
		Component Video "Pb": Blue
		Optical Digital In: Black
		Optical Digital Out: Gray

REAR-PANEL CONNECTIONS

1 Preamp Outputs: Connect these jacks to an optional, external power amplifier for applications where higher power is desired.

2 Subwoofer Output: Connect this jack to the line-level input of a powered subwoofer. If an external subwoofer amplifier is used, connect this jack to the subwoofer amplifier input.

3 Tape Outputs: Connect these jacks to the Record/Input jacks of an audio recorder.

4 A-BUS Connector: Connect this jack to optional A-BUS®-certified products to extend the multiroom capabilities of your AVR 645. See page 19 for more information on A-BUS.

5 Tape Inputs: Connect these jacks to the Play/Out jacks of an audio recorder.

6 Surround Speaker Outputs: Connect these outputs to the matching + and – terminals on your surround channel speakers. In conformance with the CEA color-code specification, the blue terminal is the positive (+) terminal that should be connected to the red (+) terminal on the Surround Left speaker with older color-coding, while the gray terminal should be connected to the red (+) terminal on the Surround Right speaker with the older color-coding. Connect the black (–) terminal on the AVR to the matching black negative (–) terminals for each surround speaker. (See page 17 for more information on speaker polarity.)

7 CD Audio Inputs: Connect these jacks to the left/right analog audio output of a compact disc player or CD changer or other audio source.

8 Front Speaker Outputs: Connect these outputs to the matching + or – terminals on your left and right speakers. When making speaker connections, always make certain to maintain correct polarity by connecting the color-coded (white for front left and red for front right) (+) terminals on the AVR 645 to the red (+) terminals on the speakers and the black (–) terminals on the AVR 645 to the black (–) terminals on the speakers. See page 17 for more information on speaker polarity.

9 Multiroom Audio Outputs: Connect these jacks to the optional external audio power amplifier and video distribution system that delivers the source selected for multizone distribution.

10 The Bridge™ Digital Media Player (DMP) Input: With the AVR 645 turned off, connect the optional Harman Kardon The Bridge™ to this connector. Once this is done and with a compatible iPod® (optional) docked in The Bridge, selecting the The Bridge/DMP input allows you to play audio from the iPod and view navigation menus on the AVR's front panel and any video display connected to the AVR. You may control the iPod's functions and select tracks using the

▲/▼/◀▶ **14 G**, **Set** **16 C** and **Transport** **17 19 20 P** buttons. See page 40 for more information.

11 Fan Vents: These ventilation holes are the output of the AVR 645's airflow system. To ensure proper operation of the unit and to avoid possible damage to delicate surfaces, make certain that these holes are not blocked and that there is at least 3 inches of open space between the vent holes and any wooden or fabric surface. It is normal for the fan to remain off at most normal volume levels. An automatic temperature sensor turns the fan on only when it is needed.

12 Full Carrier IR Output: The output of this jack is the full signal received at the **Remote Sensor Window** **16** or input through the **IR Input** **16** including the carrier frequency that is removed from signals at the **IR Output** **13**. Use this output to extend IR signals to the input of compatible products either by direct connection or through the use of optional, external IR "blasters". If you are in doubt as to which of the IR Output jacks to use, we recommend that you consult with your dealer or installer, or check with the manufacturer of the external equipment you wish to control.

13 IR Output: This connection permits the IR sensor in the receiver to serve remote controlled devices with "stripped carrier." Connect this jack to the "IR IN" jack on compatible Harman Kardon equipment.

14 Center Channel Speaker Outputs: Connect these outputs to the matching + and – terminals on your center channel speaker. In conformance with the CEA color-code specification, the green terminal is the positive (+) terminal that should be connected to the red (+) terminal on speakers with the older color-coding. Connect the black (–) terminal on the AVR to the black negative (–) terminal on your speaker. (See page 17 for more information on speaker polarity.)

15 Surround Back/Multiroom Speaker Outputs: These speaker terminals are normally used to power the surround back left/surround back right speakers in a 7.1-channel system. However, they may also be used to power the speakers in a second zone, which will receive the output selected for a multiroom system. To change the output fed to these terminals from the default of the Surround Back speakers to the Multiroom Output, you must change a setting in the Advanced menu of the OSD system. See page 46 for more information on configuring this speaker output.

In normal surround system use, the brown and black terminals are the surround back left channel positive (+) and negative (–) connections and the tan and black terminals are the surround back right positive (+) and negative (–) terminals. For multiroom use, connect the brown and black SBL terminals to the red and black connections on the left remote zone speaker and connect the tan and black SBR terminals to the red and black terminals on the right remote zone speaker.

16 IR Input: If the AVR 645's front-panel IR sensor is blocked due to cabinet doors or other obstructions, an external IR sensor may be used. Connect the output of the sensor to this jack.

17 Switched AC Accessory Outlet: This outlet may be used to power any device you wish to have turned on when the AVR 645 is turned on with the **Standby/On Switch** **1**.

IMPORTANT NOTE: The power consumption of any device connected to the accessory outlet should not exceed 100 watts. Never connect high-power devices such as amplifiers or video displays to the accessory outlet.

18 Trigger Output: Connect this jack to the "Trigger In" jack of an optional external component such as an audio power amplifier that you want to be controlled to mirror the power state of the AVR 645. When this connection is used, the AVR 645 will automatically send a low-voltage signal to the connected device that turns it on when the AVR 645 is on, and off when the AVR 645 is placed in the Standby mode. The connected component must respond to 6-volt presence as the control signal.

19 AC Power Cord Socket: Connect the AC power cord here when the installation is complete. To ensure safe operation, use only the power cord supplied with the unit. If a replacement is required, it must be of the same type and capacity.

20 RS-232 Port: This jack may be used to control the AVR 645 over a bidirectional RS-232 serial control link to a compatible computer or programmable remote control system. Due to the complexity of programming RS-232 commands, we strongly recommend that connections to this port for control purposes be made by a trained and qualified technician or installer.

21 HDMI Output: Connect this jack to the HDMI input on a compatible HDMI-equipped video display.

22 HDMI Inputs: Connect the HDMI output of video sources such as a DVD player, set-top box or HDTV tuner to either of these jacks.

23 Component Video Monitor Outputs: Connect these outputs to the component video inputs of a video display.

24 Multiroom IR Input: Connect the output of an IR sensor in a remote room to this jack to operate the AVR 645's multiroom control system.

25 Component Video Inputs: These inputs may be used with any source device that is equipped with analog component video outputs, as assigned through the **IN/OUT SETUP** menu. See page 24 for more information on configuring the component video inputs.

REAR-PANEL CONNECTIONS

- 26 Video Monitor Outputs:** Connect these jacks to the composite or S-video input of a TV monitor or video projector to view the on-screen menus and the output of any standard video source selected by the receiver's video switcher.
- 27 DVD Video Inputs:** Connect the composite or S-video outputs of a DVD player or other video source to these jacks.
- 28 Video 1 Video Inputs:** Connect the composite or S-video PLAY/OUT jacks of a VCR or other video source to these jacks.
- 29 Video 1 Video Outputs:** Connect the composite or S-video REC/IN jacks of a VCR or other video recording device such as a DVD recorder or PVR to these jacks.
- 30 Video 2 Video Inputs:** Connect the composite or S-video PLAY/OUT jacks of a VCR or other video source to these jacks.
- 31 Video 3 Video Inputs:** Connect the composite or S-video PLAY/OUT jacks of a VCR or other video source to these jacks.
- 32 XM-Ready Module Input:** When an optional XM Connect & Play module is connected to this jack, and the XM service activated, you will be able to enjoy the XM Radio through your AVR 645. See page 41 for more information.
- 33 USB Connector:** Connect a cable with a USB "Mini B" connector to the AVR and the other end to a compatible computer running Windows® 2000, Windows XP or higher with the latest service packs installed, to use this port to listen to audio from the computer through the AVR 645. This connection is also used to connect a compatible computer to the AVR for firmware upgrades, when available. See page 39 for more information on playback of computer audio with the AVR. Instructions for upgrades will accompany the upgrade file download package.
- 34 Optical Digital Audio Output:** Connect this jack to the optical digital input connector on a CD-R/RW, MiniDisc or other compatible digital recorder.
- 35 Coaxial Digital Audio Output:** Connect this jack to the coaxial digital input of a CD-R/RW, MiniDisc or other compatible digital recorder.
- 36 DVD Audio Inputs:** Connect the left/right analog outputs of a DVD player or other audio source to these jacks.
- 37 Coaxial Digital Audio Inputs:** Connect the coax digital output from a DVD player, HDTV receiver, LD player or CD player to these jacks. The signal may be a Dolby Digital signal, DTS signal or a standard PCM digital source. Do not connect the RF digital output of an LD player to these jacks.
- 38 Optical Digital Audio Inputs:** Connect the optical digital output from a DVD player, HDTV receiver, LD player or CD player to these jacks. The signal may be a Dolby Digital signal, a DTS signal or a standard PCM digital source.
- 39 8-Channel Direct Inputs:** These jacks are used for connection to source devices such as high-resolution DVD players, DVD-Audio or SACD players with discrete analog audio outputs. Depending on the source device in use, all eight jacks may be used, though in many cases only connections to the front left/right, center, surround left/right and LFE (sub-woofer input) jacks will be used for 5.1 audio signals.
- 40 Video 1 Audio Inputs:** Connect the left/right PLAY/OUT audio output jacks on a VCR or other video source to these jacks.
- 41 Video 2 Audio Inputs:** Connect the left/right PLAY/OUT audio output jacks on a VCR or other video source to these jacks.
- 42 Video 3 Audio Inputs:** Connect the left/right PLAY/OUT audio output jacks on a VCR, PVR, cable set-top, satellite receiver, HDTV receiver or other video source to these jacks.
- 43 Video 1 Audio Outputs:** Connect the left/right REC/IN audio input jacks on a VCR or other video source to these jacks.
- 44 FM Antenna Jack:** Connect the supplied indoor or an optional external FM antenna to this terminal.
- 45 AM Antenna Connections:** Connect the AM loop antenna supplied with the receiver to these terminals. If an external AM antenna is used, make connections to the **AM** and **GND** terminals in accordance with the instructions supplied with the antenna.

MAIN REMOTE CONTROL FUNCTIONS

- 1 Power Off Button
- 2 Power On Button
- 3 LCD Information Display
- 4 Input Selectors
- 5 AVR Selector
- 6 Test Button
- 7 DSP Surround Mode Selector
- 8 Logic 7 Mode Select Button
- 9 Direct Button
- 10 Clear Button
- 11 EzSet/EQ On/Off Button
- 12 Tuning Mode Button
- 13 Channel Select Button
- 14 Navigation Button
- 15 Digital Select Button
- 16 Set Button
- 17 Transport Play Buttons
- 18 Volume Up/Down Selectors
- 19 Transport Fast-Play/Scan Buttons
- 20 Main Transport Controls
- 21 Track Skip Up/Down Buttons
- 22 Preset Up/Down Button
- 23 Tuning Up/Down Button
- 24 Disc Skip Button
- 25 Program Button
- 26 Light Button
- 27 Multiroom Button
- 28 Macro Buttons
- 29 Sleep Button
- 30 Night Mode Button
- 31 OSD Button
- 32 Tone Control Button
- 33 Dim Button
- 34 Tuner/FM Select Button
- 35 Channel Up/Down Selector
- 36 Delay Select Button
- 37 Speaker Select Button
- 38 Memory Button
- 39 Numeric Keys
- 40 Stereo Mode Select Button
- 41 DTS Neo:6 Mode Select Button
- 42 DTS Digital Mode Select Button
- 43 Dolby Mode Select Button
- 44 6-Channel/8-Channel Input Select
- 45 Mute Button
- 46 Lens

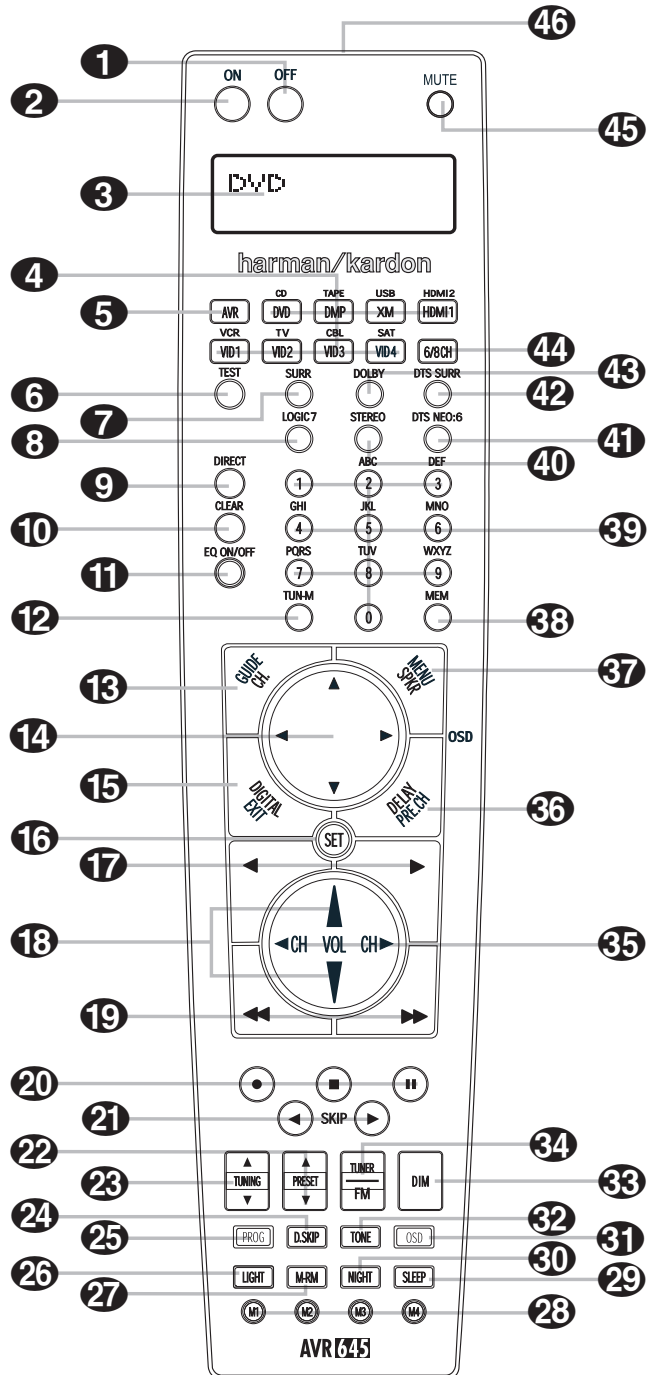

NOTES:

- The function names shown here are each button's feature when used with the AVR 645. Most buttons have additional functions when used with other devices. When a button is pressed, the function name will appear in the bottom line of the LCD Information Display 3.
- The jack on the upper right side of the remote is reserved for future use. Do not remove the plug provided or connect any device to the jack.
- To make it easier to follow the instructions that refer to this illustration, a larger copy may be downloaded from the Product Support section for this product at www.harmankardon.com.

MAIN REMOTE CONTROL FUNCTIONS

IMPORTANT NOTE: The AVR 645's remote may be programmed to control up to thirteen devices, including the AVR 645. Before using the remote, it is important to remember to press the **Input Selector Button 4** that corresponds to the unit you wish to operate. In addition, the AVR 645's remote is shipped from the factory to operate the AVR 645 and most Harman Kardon CD or DVD players and cassette decks. The remote is also capable of operating a wide variety of other products using the control codes that are part of the remote. Before using the remote with other products, follow the instructions on pages 48–51 to program the proper codes for the products in your system.

It is also important to remember that many of the buttons on the remote take on different functions, depending on the product selected using the **Input Selectors 4**. The descriptions shown here primarily detail the functions of the remote when it is used to operate the AVR 645.

1 Power Off Button: Press this button to place the AVR 645 or a selected device in the Standby mode. Note that this will turn off the main room functions, but if the Multiroom system is activated, it will continue to function.

2 Power On Button: Press this button to turn on the power to a device selected by first pressing one of the **Input Selectors 4**.

3 LCD Information Display: This two-line screen displays various information, depending on the commands that have been entered into the remote.

4 Input Selectors: Pressing one of these buttons will perform three actions at the same time. First, if the AVR 645 is not turned on, this will power up the unit. Next, it will select the source shown on the button as the input to the AVR 645. Finally, it will change the remote control so that it controls the device selected.

The buttons labeled DVD, DMP, XM and HDMI 1 are each used to select either of two input sources:

- The first press of the DVD Button selects the component connected to the DVD inputs. A second press of this button selects the component connected to the CD inputs.
- The first press of the button labeled DMP selects The Bridge as the input. A second press of this button selects the device connected to the Tape inputs.
- The first press of the XM button selects XM Radio as the input. A second press selects the source connected to the USB jack as the input.
- The first press of the HDMI 1 button selects the device that is connected to the HDMI 1 jack. A second press selects the device connected to the HDMI 2 jack.

In normal operation, the remote will revert to controlling the AVR when no button is pressed for 6 seconds. This allows the remote to automatically return to control of important functions such as volume, mute and surround mode selection after you have used the remote to control another device. If you wish to change the length of time that the remote operates another device, or to have the remote remain active for control of the other device (such as a DVD player or set-top box) until you manually return control to the AVR by pressing the **AVR Selector 5**, follow the instructions on page 57.

5 AVR Selector: Pressing this button will switch the remote so that it will operate the AVR 645's functions. If the AVR 645 is in the Standby mode, it will also turn the AVR 645 on.

6 Test Button: Press this button to begin the sequence used to manually calibrate the AVR 645's output levels. (See page 33 for more information on manually calibrating the AVR 645.)

7 DSP Surround Mode Selector: Press this button to select one of the DSP surround modes, such as Hall 1, Hall 2 or Theater. Each press of the button selects another mode. (See page 60 for more information on surround modes.)

8 Logic 7 Mode Select Button: Press this button to select from among the available Logic 7 surround modes. (See page 60 for available Logic 7 options.)

9 Direct Button: Press this button when the tuner is in use to start the sequence for direct entry of a station's frequency. After pressing the button, simply press the proper **Numeric Keys 39** to select a station. (See page 41 for more information on the tuner.)

10 Clear Button: When programming the remote or using the EzSet feature, press this button to cancel the current function. When using the remote to enter frequencies for direct tuner access, press this button to clear previous entries.

11 EzSet/EQ Button: Press this button to turn the filters used by EzSet/EQ on or off. This allows you to hear the difference in system performance when EzSet/EQ is engaged or out of the signal path.

12 Tuning Mode Button: When using listening to AM or FM stations, press this button to change the tuner mode between manual and automatic. When the button is pressed so that **AUTO/STEREO** appears in the **Upper Display Line 13** and in the on-screen display, only stations with acceptable signal quality will be tuned, and the tuner will play FM stations in stereo, when available. In the **AUTO** mode, when the **Tuning Up/Down Buttons 4 23 P** are pressed, the unit will automatically search for the next available station with good signal strength. When this button is pressed so that **MANUAL/MONO**

appears in the **Upper Display Line 13** and in the on-screen display, each press of the **Tuning Up/Down Buttons 4 23 P** will move the frequency up or down in single-step increments. When the FM band is in use, pressing the button so that the **MANUAL** mode is activated will enable you to tune stations with weak signals by changing to monaural reception. (See page 41 for more information on AM/FM tuner operation.) When listening to XM Radio, press this button to scroll through the following display options for the **Lower Display Line 14**: Channel Name → Channel Category → Artist → Title. (See pages 41–42 for more information on XM Radio operation.)

13 Channel Select Button: This button is used to start the process of manually setting the AVR 645's output levels to an external source. Once this button is pressed, press the **▲/▼ Navigation Button 14** to select the channel being adjusted, then press the **Set Button 16**, followed by the **▲/▼ Navigation Button 14** again, to change the level setting. (See page 42 for more information.)

14 Navigation Button: This single disc-like button is used to navigate through the on-screen configuration menus, to scroll through the options list and to select choices for the various settings such as delay, speakers, surround modes, digital inputs, etc. To use the button, simply press it left, right, up or down in the direction indicated by the **▲/▼/◀/▶** icons printed on the button disc. Depending on the menu being used, pressing the button will either change a specific menu or configuration choice, or change the option shown in the on-screen or front-panel display. The sections in this manual describing the unit's individual features and configuration options contain specific information on how navigation controls are used.

15 Digital Select Button: Press this button to assign one of the digital inputs **37 38 KIM** to a source.

16 Set Button: This button is used to enter settings into the AVR 645's memory. It is also used in the setup procedures for delay time, speaker configuration and channel output level adjustment.

17 Transport Play Buttons: These buttons have no direct function on the AVR 645, but they are used when the remote is programmed for a compatible DVD, CD or tape player. Pressing these buttons will transmit a forward- or reverse-play command, according to the capabilities of the player being controlled. In the factory default setting, these buttons are programmed for Harman Kardon DVD players so that you may control a compatible player without having to switch devices.

18 Volume Up/Down Selectors: These controls share the common disc in the lower third of the remote. To raise the volume, press the button marked **▲** by pressing toward the top of the remote. To lower

MAIN REMOTE CONTROL FUNCTIONS

the volume, press the button marked ▼ by pressing toward the bottom of the remote. The ◀▶ buttons on the left and right sides of this disc change channels up or down when the TV, cable box or satellite **Input Selectors** 4 have been pressed.

19 Transport Fast-Play/Scan Buttons: These buttons have no direct function on the AVR 645, but they are used when the remote is programmed for a compatible DVD, CD or tape player. Pressing these buttons will transmit a fast-play forward, fast-play reverse, or fast-forward or -reverse scan command, according to the capabilities of the player being controlled. In the factory default setting, these buttons are preprogrammed with the remote codes for Harman Kardon DVD players so that you may control a compatible player without having to switch devices.

20 Main Transport Controls: These buttons have no direct function on the AVR 645, but they are used when the remote is programmed for a compatible DVD, CD or tape player. Pressing these buttons will transmit a stop (■), record (●), or pause (⏸) command, according to the capabilities of the player being controlled. In the factory default setting, these buttons are programmed with the remote codes for Harman Kardon DVD players so that you may control a compatible player without having to switch devices.

21 Track Skip Up/Down Buttons: These buttons do not have a direct function with the AVR 645, but when used with a compatibly programmed CD or DVD changer, they will change the track or chapter currently being played. In the factory default setting, these buttons are programmed with the remote codes for Harman Kardon DVD players so that you may control a compatible player without having to switch devices.

22 Preset Up/Down Button: When the tuner is in use, press this button to scroll through the stations programmed into the AVR 645's memory.

NOTE: When the AVR 645 is used with The Bridge (optional) and your iPod, some of the buttons that are used to control the various transport functions on source devices are used to control the iPod, and navigate through its menus and content. Consult the owner's manual packed with The Bridge for more information.

23 Tuning Up/Down Button: Press this button when the tuner is in use to change the station to one with a higher or lower frequency, or to change the XM channel. When the tuner is in the **MANUAL/MONO** mode, each tap of the selector will increase or decrease the frequency by one increment. When the tuner receives a signal sufficient for adequate reception, **MANUAL TUNED** will appear in the **Lower Display Line 14** and in the on-screen display. When the tuner is in the **AUTO/STEREO** mode, press the button once, and the tuner will scan for a

station with acceptable signal strength. When the next higher- or lower-frequency station with a strong-enough signal is tuned, the frequency scan will stop and the **Lower Display Line 14** and the on-screen display will indicate **AUTO TUNED**. When an FM Stereo station is tuned, the display will read **AUTO ST TUNED**. See page 41 for more information on using the tuner.

24 Disc Skip Button: This button has no direct function for the AVR 645 but may be used to change the disc in a CD or DVD changer when the remote is programmed for that type of device.

25 Program Button: This button is used to begin the process of programming the remote. Press and hold this button for 3 seconds to place the remote in the programming mode. Once the red LED under the **Set Button 16** lights, release the button. You may then select from the desired option. (See pages 48–58 for more information on configuring the remote.)

26 Light Button: Press this button to activate the remote's backlight for ease of use in darkened rooms.

27 Multiroom Button: Press this button to begin the process of activating the multiroom system or to change the input or volume level for the second zone. (See page 46 for additional information on the multiroom system.)

28 Macro Buttons: Press these buttons to store or recall a "Macro", which is a preprogrammed sequence of commands stored in the remote. (See page 51 for more information on macros.)

29 Sleep Button: Press this button to place the unit in the Sleep mode. After the time shown in the display, the AVR 645 will automatically go into the Standby mode. Each press of the button changes the time until turn-off in the following order:

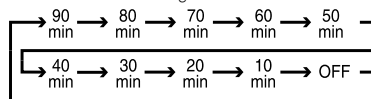

When the Sleep timer is in use, the front-panel display indicators will dim to half-brightness.

30 Night Mode Button: Press this button to activate the Night mode. The Night mode is available in specially encoded Dolby Digital sources, and it preserves dialogue (center channel) intelligibility at low volume levels.

31 OSD Button: Press this button to activate or turn off the On-Screen Display (OSD) system used to set up or adjust the AVR 645's parameters.

32 Tone Control Button: This button controls the tone mode settings, enabling adjustment of the bass and treble boost/cut. You may also use it to take the tone controls out of the signal path completely for "flat" response. The first press of the button displays a **TONE IN** message in the **Lower Display Line**

14 and in the on-screen display. To take the controls out of the signal path, press either of the ▲/▼ **Navigation Buttons 14** until the display reads **TONE OUT**. To change the bass or treble set-tings, press the button again until the desired option appears in the **Lower Display Line 14** and in the on-screen display and then press either of the ▲/▼ **Navigation Buttons 14** to enter the desired boost or cut setting. See page 37 for more information on the tone controls.

33 Dim Button: Press this button to activate the Dimmer function, which reduces the brightness of the front-panel display, or turns it off entirely. Press the button once to change the display to reduce the brightness by 50%, and press it again within 5 seconds and the main display will go completely dark. Note that this setting is temporary; regardless of any changes, the display will always return to full-brightness when the AVR is turned on. The blue illumination around the **Standby/On Switch 1** will always remain at full-brightness, regardless of the setting, to remind you that the AVR is still turned on. The blue accent lighting inside the volume control will also remain at full-brightness when the panel is at 50%, but go out when the panel lights are fully dimmed.

34 Tuner/FM Select Button: This button functions in two ways. Press it up, toward the top of the remote, to select the tuner as the AVR's input. The first press will call up the last-used station (or XM channel). Subsequent presses will select the last-used FM, AM and XM Radio station or channel. When the button is pressed down, toward the bottom of the remote, the last-tuned FM station is selected as the AVR's input.

35 Channel Up/Down Selector: This button has no function when the AVR is being controlled, but when programmed for use with a VCR, TV, cable box, satellite receiver or other similar product, it will change the channel up or down. See pages 48–58 for more information on programming the remote.

36 Delay Select Button: This button selects adjustments to the A/V Sync Delay and the individual channel delays. The first press of the button displays an **A/V SYNC DELAY** message in the **Lower Display Line 14** and in the on-screen display, which means that you may change the amount of time that all channels are delayed together behind the video. This enables you to compensate for the loss of lip sync that may be caused by digital video processing in your display or by television stations. To change the A/V Sync Delay, press the **Set Button 16** while the **A/V SYNC DELAY** message is visible, and then use the ▲/▼ **Navigation Buttons 14** to change the setting so that the sound and the video image are in sync. To change the delay for an individual output channel, press the ▲/▼ **Navigation Button 14** until the desired channel name is shown, and then press the **Set Button 16**.

MAIN REMOTE CONTROL FUNCTIONS

Use the ▲/▼ **Navigation Buttons 14** to change the delay amount. (See page 32 for more information on delay options.)

37 Speaker Select Button: Press this button to begin the process of manually configuring the AVR 645's bass management system. Then press the ▲/▼ **Navigation Buttons 14** to select the channel you wish to set up. Press the **Set Button 16** and then select another channel to configure. When all adjustments have been completed, press the **Set Button 16** twice to exit the settings and return to normal operation. (See page 30 for more information on manual speaker setup.)

38 Memory Button: Press this button to enter a radio station in the AVR 645's preset memory. First, tune the desired station, and then press this button. Within 5 seconds of when you see the station's frequency flash in the **Upper Display Line 13** and in the on-screen display, press the numeric keys for the preset number between 01 and 30 that you wish to assign to the station. (See page 41 for more information.)

39 Numeric Keys: These buttons serve as a 10-button numeric keypad to enter tuner preset positions. They are also used to select channel numbers when TV, Cable or SAT has been selected on the remote, or to select track numbers on a CD, DVD or LD player, depending on how the remote has been programmed. These buttons are also used to enter letters and numbers when renaming devices in the LCD Information Display. (See page 55 for more information on renaming devices and keys.)

40 Stereo Mode Select Button: Press this button to select a stereo listening mode. When the button is pressed so that **SURROUND OFF** appears in the **Lower Display Line 14**, the AVR will operate in a bypass mode with true, fully analog, two-channel left/right stereo mode with no surround processing or bass management, as opposed to other modes where digital processing is used. When the button is pressed so that **SURROUND OFF** appears in the **Lower Display Line 14**, and both the **DSP** and **Surround Off Surround Mode Indicators 15** are lit, you will enjoy a two-channel presentation of the sound, along with the benefits of bass management. Depending on whether your system is configured for 5.1 or 6.1/7.1 channels, the next press of the button will cause either **5 CH STEREO** or **7 CH STEREO** to appear, and the stereo signal will be routed to all five (or seven) speakers. (See page 60 for more information on stereo playback modes.)

41 DTS Neo:6 Mode Select Button: Press this button to select a DTS Neo:6 mode. (See page 60 for the available DTS Neo:6 options.)

42 DTS Digital Mode Select Button: When a DTS-encoded digital source is playing, each press of this button will scroll through the available DTS modes. The specific choice of modes will vary according to the type of encoding on the disc and your system's speaker configuration. When a DTS source is not in use, this button has no function. (See page 60 for the available DTS digital options.)

43 Dolby Mode Select Button: This button is used to select from the available Dolby Surround modes. Each press of this button will select one of the Dolby Pro Logic II, Dolby Pro Logic IIx or Dolby Virtual Speaker modes, as available for the number of speakers in your system. When a Dolby Digital-encoded source is in use, the Dolby Digital mode may also be selected. (See page 60 for the available Dolby surround mode options.)

44 6-Channel/8-Channel Input Select: Press this button to select the device connected to the **8-Channel Direct Inputs 39**.

45 Mute Button: Press this button to momentarily silence the AVR 645 or TV set being controlled, depending on which device has been selected.

46 Lens: The infrared emitters behind the plastic lens at the top of the remote communicate the remote codes to the AVR 645. Be certain that the lens is not covered when using the remote, and point the lens toward the AVR for best results. In learning mode, the remote receives IR codes to be learned through a sensor behind the lens.

NOTE: DO NOT remove the rubber plug that covers the jack on the upper right side of the remote. The jack is not active and is reserved for future use.

INSTALLATION AND CONNECTIONS

7. The default audio connection for a DVD player is to link the coaxial digital audio output on the DVD player to the **Coaxial 1 Digital Audio Input 47**, but you may also make a connection to either the **Coaxial 47** or **Optical 38** digital inputs, or the **Analog DVD Audio Inputs 36**. You may change the assignment in the **IN/OUT SETUP** menu as described on page 24, or by using the front-panel **Digital Input Selector F**.
8. To use a portable audio/video product such as a camcorder, media player or digital still camera with the AVR, or connect a video game console or other source that may not always be connected to the AVR, connect the video outputs of the source to the **Video 4 Input/Output Jacks N**, behind the **Front-Panel Door 9**. If the source has digital audio outputs, connect them to the **Optical 4 Digital Input K** or the **Coaxial 4 Digital Jack M**.

CONNECTION NOTES:

- When making connections to the **Component Video Inputs 25** or the **Coaxial 47** or **Optical 38** digital audio inputs, it is a good idea to make note of which jacks are connected to which source, using the Worksheet in the Appendix. This will help simplify the configuration process.
 - When connecting a source device such as a cable set-top box where the audio streams may change between digital and analog as you change channels, we recommend that you make both analog and digital connections. The AVR's Auto Poll feature will automatically sense when the digital stream is replaced by an analog output and switch the input accordingly. (See page 24 for more information on the Auto-Poll feature.) This dual connection is not required for sources (such as DVD players or video games) that always output a digital stream.
9. Connect the AVR to your video display using one of the following connections:
- If you have a video display with an HDMI or DVI input, make the connection using the **HDMI Output 21**, as described in the next section.
 - If your video display has component video inputs (Y/Pr/Pb), connect the **Component Video/Monitor Outputs 23**.
 - If your display does not have digital or component video inputs, connect the **Video Monitor Output 26** on the AVR to the matching input on your display. Only one connection is needed, and S-video is the higher quality signal.

HDMI Connections

HDMI™ is the abbreviation for High-Definition Multimedia Interface, which is quickly becoming the standard connection point between advanced video/audio source products and displays, particularly for high-definition video signals. HDMI is a digital connection, eliminating the need to con-

vert signals back and forth from digital to analog to deliver a higher quality signal when used with digital sources. The signals carried on HDMI may, but do not always, include audio, offering the possibility of a complete one-wire connection from a source to the AVR. However, it is important to note that there are a number of different versions of the HDMI standard in use. Before connecting any HDMI products to your AVR, it is helpful to find out in advance their level of HDMI connectivity.

Some source or display components in your system may use DVI (Digital Video Interface) for digital video connections. DVI carries the same digital video signals as HDMI but uses a larger connector and does not transport audio or control signals. In most cases, you may mix and match DVI and HDMI digital video connections by using optional connector adapters. Note, however, that some DVI-equipped video displays are not compatible with the HDCP copy protection coding that is increasingly carried with signals connected via HDMI. If you have an HDMI source and a DVI-equipped display, you may occasionally be unable to view a program if the display does not include HDCP. This is not the fault of the AVR or your source; it simply indicates that the video display is not compatible.

HDMI Input Connections

The different "Version" levels of HDMI define which type of audio signals it is compatible with. Based on the lowest level of HDMI among your sources, the connections to the AVR should be made as follows:

- **HDMI 1.0** sources carry digital video and multi-channel or 2-channel PCM audio signals only. Connect the HDMI output of a 1.0 source to either of the **HDMI Inputs 22** on the AVR. If the product is a DVD-Audio player or other source that has multichannel analog audio outputs, connect them to the **8-Channel Direct Inputs 49**. With an HDMI 1.0 source, particularly a DVD player, make certain that the menus in the source device are set to "Bitstream Out" or "Original" so that 5.1 digital audio is available. If you find that 5.1 Dolby Digital or DTS audio is not available on the HDMI connection, it will be necessary to make an additional connection between the source and the AVR 645 to either the **Coaxial 47/M** or **Optical 38/K Digital Inputs**.
- **HDMI 1.1** sources carry the multichannel digital audio output from DVD-Audio players in addition to the digital video. If you have an HDMI 1.1-equipped product, the only connection needed for listening in the main room is from the HDMI output of the source to either of the **HDMI Inputs 22** on the AVR. If the player has SACD capability, you will need to connect the analog outputs of the source to the **8-Channel Direct Inputs 49**.
- **HDMI 1.2** (and higher) sources should be connected as shown above for HDMI 1.1.
- It is not possible to feed an analog audio or composite or S-video signal to a recorder or the AVR's

multizone system when an HDMI input is in use. If an HDMI-equipped source also has analog audio and video outputs, connect them to the **Video 2** or **Video 3 Video 30/31** and **Audio 41/42** inputs.

- In some instances, HDMI-equipped sources will not permit more than one video output at a time, and thus you cannot use the same source in the main listening room, and with the recorder at the same time. This is not a fault of the AVR, but rather a function of the content-protection systems that are part of the HDMI standard.

HDMI Output Connections

Connect the **HDMI Output 21** to an HDMI input on your video display. Thanks to the AVR 645's video processing system, all video input signals are converted to an HDMI output, so only one connection is required between the AVR and your display.

System and Power Connections

The AVR 645 is designed for flexible use with multiroom systems, external control components and power amplifiers.

Main Room Remote Control Extension

If the receiver is placed behind a solid or smoked-glass cabinet door, the obstruction may prevent the remote sensor from receiving commands. In this event, an optional remote sensor may be used. Connect the output of the remote sensor to the **IR Input 16**.

If other components are also prevented from receiving remote commands, only one sensor is needed. Simply use this unit's sensor or a remote eye by running a connection from the **IR Output 13** to the Remote IR Input jack on Harman Kardon or other compatible equipment.

If other Harman Kardon-compatible source equipment is part of the main room installation, the **IR Output Jack 13** on the rear panel should be connected to the **IR IN** jack on source equipment. This will enable the remote room location to control source equipment functions.

When a remote IR sensor is used to control non-Harman Kardon source equipment, we recommend that you make a hard-wire connection or use an optional, external IR "blaster" connected to the **Full Carrier IR Output 12**. If you are in doubt as to which IR Output jack to use for the equipment in your system, contact your dealer or installer, or the manufacturer's support site and ask whether the unit to be controlled uses "full carrier" IR commands. When "full carrier" commands are used, make the connection to the **Full Carrier IR Output 11**. Otherwise, make the connection to the **IR Output 13**.

NOTE: All remotely controlled components must be linked together in a "daisy chain". Connect the **IR OUT** jack of one unit to the **IR IN** of the next to establish this chain.

INSTALLATION AND CONNECTIONS

Multiroom Audio Connections

The AVR 645 is equipped with multizone capabilities that allow it to send a separate audio source to the remote zone from the one selected for use in the main room.

Depending on your system's requirements, three options are available for audio connection:

Option 1: Use high-quality, shielded audio interconnect cable from the AVR 645's location to the remote room. In the remote room, connect the interconnect cable to a stereo power amplifier. The amplifier will be connected to the room's speakers. At the AVR 645, plug the audio interconnect cables into the **Multiroom Audio Outputs 9** on the AVR 645's rear panel.

Option 2: Connect the **Multiroom Audio Outputs 9** on the AVR 645 to the inputs of an optional stereo power amplifier. Run high-quality speaker wire from the amplifier to the speakers in the remote room.

Option 3: Taking advantage of the AVR 645's built-in seven-channel amplifier, it is possible to use two of the amplifier channels to power speakers in the remote room. When using this option, you will not be able to use the full 7.1-channel capabilities of the AVR 645 in the main listening room, but you will be able to add another listening room without external power amplifiers. To use the internal amplifiers to power a remote zone, connect the speakers for the remote room location to the **Surround Back/Multiroom Speaker Outputs 15**. Before using the remote room, you will need to configure the amplifiers for surround operation by changing a setting in the **MULTIROOM** menu, following the instructions shown on page 46.

NOTE: For all options, you may connect an optional IR sensor in the remote room to the AVR 645 via an appropriate cable. Connect the sensor's cable to the **Multiroom IR Input 24** on the AVR 645 and use the ZR 10 remote to control the room volume. You may install an optional volume control between the output of the amplifiers and the speakers in options 1 and 2.

A-BUS® Installation Connections

The AVR 645 is among the few receivers available that offer built-in A-BUS/READY operation. When used with an optional A-BUS product, you have all the benefits of remote zone operation without the need for an external power amplifier.

To use the AVR 645 with an approved A-BUS product, simply connect it to the AVR 645 using standard Category 5 wiring that is properly rated for the specific in-wall installation. Terminate the wiring at the receiver end to a standard RJ-45 connector in compliance with the instructions furnished with the A-BUS product. No further installation or adjustment is needed, as the A-BUS jack on the AVR 645 routes the signals to their

proper destination for power, signal source and control. The output fed to the A-BUS jack is determined by the AVR 645's multiroom system and menus.

RS-232 Connections

The AVR 645 is equipped with an **RS-232 Serial Connection Port 20** that may be connected to a compatible, optional, external computer, keypad or control system for bidirectional communications that enable the external system to control the AVR, and for the AVR to report status and handshake data back to the controller. Use of the RS-232 port for this type of control requires specific technical knowledge, and we recommend that any connection and programming for control be made by a trained installer or technician familiar with the equipment being used.

The physical connection to the AVR 645's RS-232 port is a standard D-SUB 9 connection, but to ensure compatible and proper operation, specific software commands and pin wiring schemes may be required.

USB Connections

The AVR 645 is one of the few AV receivers to offer a USB connection that may be used for both playback of compatible audio content from a computer and for loading of system updates (when available).

The physical connection between a computer and the AVR is a simple one, requiring only a cable with a USB "A" type connector on one side and a USB "Mini B" on the other.

Connect the larger, "A" connector on the cable to your computer or a USB hub and the end with the "Mini" USB connector to the **USB Port 33** on the AVR's rear panel.

NOTES ON USB:

- The USB port on the AVR 645 is for connection to a computer, or to a hub connected to a computer, only. DO NOT connect it directly to other devices such as card readers, USB memory storage devices, external hard drives, USB accessories, digital cameras or cellular phones. Connection to these devices may cause damage to the device and/or the AVR that is not covered by the AVR's warranty.
- The AVR 645's USB connection may only be used for audio playback and system upgrades. It may not be used for other purposes, such as system control, video or still-image playback.

Trigger Connection

The AVR 645 is equipped with a low-voltage trigger that may be used to control a wide variety of compatible, optional devices that respond to voltage actuation commands. This includes external audio power amplifiers, video screens, motorized blinds and other compatible products in a home theater or automation system.

Due to the complexity of interfacing with power-controlled devices, we strongly recommend that they be installed by a qualified professional.

The trigger jack delivers 5 volts DC when activated, and remove the voltage when they are off. The connection is a 3.5mm mono mini plug with the signal on the center pin ("tip") and the outer shaft ("ring") acting as the negative or ground connection.

The **Trigger Output 18** is for use with devices such as power amplifiers that you wish to activate whenever the AVR is turned on, regardless of the input selected.

After checking for voltage, current and polarity compatibility between the device being controlled and the AVR, simply connect one end of the trigger cable to the device being controlled and the other end to the **Trigger Output 18** on the AVR.

IMPORTANT NOTE ON THE TRIGGER CONNECTION:

The current draw from the trigger jack cannot exceed 1.0mA.

XM Radio Connections

XM Radio is a satellite-delivered, subscription-based, programming service that provides a wide range of music, sports, news and information programming with digital audio quality. The AVR 645 is XM Connect and Play-ready, which means that you can easily add the XM service to your home audio system by purchasing an XM antenna module or Passport system, activating an account with XM and then making a simple, single-cable connection to your AVR.

To purchase an XM antenna module or Passport system, consult your dealer, or contact XM Radio at www.xmradio.com. After following the instructions packed with the module, place the XM antenna near a south-facing window and run the cable to the AVR. Connect the plug at the end of the cable to the **XM-Ready Module Input 32**. If you are using an XM Passport system, remember that the Passport card must be inserted for the system to operate. Once the connection is made, follow the instructions on page 41 for more information on listening to XM Radio.

NOTES on XM Radio:

- XM Radio requires the purchase of additional, optional hardware and a separate subscription to the XM service.
- XM Radio is available only in the continental United States and Canada. It is not available in Alaska or Hawaii.
- XM reception requires that the antenna be able to "see" the XM satellites or receive a signal from one of the XM ground-based repeaters. Depending on your installation and location, XM service may not be available in some areas.

AC Power Connections

This unit is equipped with an accessory AC outlet that may be used to power accessory devices, but it should not be used with high-current draw equipment such as power amplifiers. The total power draw may not exceed 100 watts.

INSTALLATION AND CONNECTIONS

This **Switched AC Accessory Outlet 17** is powered only when the unit is on. This is recommended only for devices that have a mechanical power switch that may be left in the "ON" position.

NOTE: Many audio and video products go into a Standby mode when they are used with switched outlets. This type of product may not operate properly when used with the switched outlet.

The AVR 645 features a removable power cord that allows wires to be run in advance to a complex installation so that the unit itself need not be installed until it is ready for connection. When all needed connections have been made, connect the AC power cord to the **AC Power Cord Jack 19**.

The AVR 645 draws significantly more current than other household devices, such as computers, that use removable power cords. For that reason, it is important that only the cord supplied with the unit (or a direct replacement of identical capacity) be used.

Once the power cord is connected, you are almost ready to enjoy the AVR 645's incredible power and fidelity!

OPERATION

Basic Operation

Once you have completed the initial setup and configuration, the AVR 645 is simple to operate and enjoy. The following instructions will help you maximize the enjoyment of your new receiver:

Turning the AVR 645 On or Off

- When using the AVR for the first time, you must press the **Main Power Switch A** in until it latches. This places the unit in a Standby mode, as indicated by the amber illumination surrounding the **Standby/On Switch 1**.
- To turn the AVR on or off from the front panel, press the **Standby/On Switch 1**.
- To turn the unit on and select the input source that was in use the last time the AVR was on, press the **AVR Selector 5 C** on either remote.
- To turn the unit on and select a specific source, press any one of the **Input Selectors 4 34 44** on the main remote or **DEFR** on the ZR 10 remote .
 - When using the **Input Selector Buttons 4** labeled DVD, DMP, XM or HDMI on the main remote, remember that these are dual-input selectors. The first press of any button will turn the unit on and select the input name printed on the button. A second press of the button will select the input name printed above the button.
 - To turn the AVR on and select the Tuner as an input, press the **Tuner/FM Select Button 34** by pressing the button up towards the top of the remote. The first press of the button selects the frequency band and station or XM channel that was last tuned. Press the button again to select between FM, AM and XM.
 - To turn the AVR on and select the FM tuner as the input, press the **Tuner/FM Select Button 34** down towards the bottom of the remote.
 - When using any of the Input Selectors to turn the unit on (or when using them to change a source at any time) press the **AVR Selector 5 C** after the unit turns on to use any of the buttons on the remote to control AVR functions other than volume or source selection.

Whenever the AVR is turned on, you will see all of the front-panel indicators light up for a few seconds. This is normal, and it is part of the unit's power-on self-test procedure.

To turn the unit off at the end of a listening session, simply press the **Standby/On Switch 1** on the front panel or the **Power Off Button 1 A** on the remote. Power will be shut off to any equipment plugged into the rear-panel **Switched AC Accessory Outlet 17** and the illumination around the **Standby/On Switch 1** will turn amber.

When the remote is used to turn the unit "off," it is actually placing the system in a Standby mode, as indicated by the amber lighting around the **Standby/On Switch 1**.

- To put the AVR in the Sleep mode, press the **Sleep Button 29**. Each press of the button will decrease the time before the AVR shuts down in the following sequence.

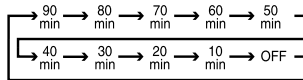

Once you have set the desired Sleep Time, the front-panel display will automatically dim to half-brightness. The display will return to full-brightness when any button on the front panel or a remote is pressed, and then return again to half-brightness. To view the time remaining until the unit shuts down, press the **Sleep Button 29** once. To cancel the Sleep function, press the **Sleep Button 29** as many times as needed until the words **SLEEP OFF** appear in the **Lower Display Line 14**.

When you will be away from home for an extended period of time, it is always a good idea to completely turn the unit off with the front-panel **Main Power Switch A**.

NOTE: All preset memories are lost if the unit is left turned off by using the **Main Power Switch A** for more than four weeks.

Source Selection

- To select an input source from the front panel, press the **Input Source Selector Button 7**. Each press of the button will move the input selection through the list of available choices. If the button is pressed when the AVR is in the Standby mode, the first press of the button will turn the unit on and select the last used input.
- When the AVR is already turned on, you may select the tuner directly by pressing the **Tuner Band Selector 5**. The first press will select the last tuned frequency band and station. Each subsequent press will change the band to the last tuned station or XM preset.
- To select a specific source using the main remote, press any one of the **Input Selectors 4 34 44** on the main remote. Remember that the Input Selector Buttons labeled DVD, DMP, XM or HDMI are dual-input selectors. The first press of any button will turn the unit on and select the input name printed on the button. A second press of the button will select the input name printed above the button.
- To directly select the Tuner as an input, press the **Tuner/FM Select Button 34** by pressing the button up towards the top of the remote. The first press of the button selects the frequency band and station or

XM channel that was last tuned. Press the button again to select between FM, AM and XM.

- To directly select the FM tuner as the input, press the **Tuner/FM Select Button 34** down towards the bottom of the remote.
- To select a specific source using the ZR 10 remote, press any of the **Input Selectors DEFR**. When selecting the **Tuner Selector E** scrolls through the choice of FM, AM or XM Radio (when an optional XM Ready or Passport module is installed and the XM service has been activated).

REMINDER: When using any of the Input Selectors to change a source, you must press the **AVR Selector 5 C** to control AVR functions other than volume or source selection.

- When a new input is selected, the AVR will automatically switch to the digital input (if selected), surround mode, component video input, A/V sync delay and Night mode configurations that were in effect the last time that input was used.
- The front-panel **Video 4 Inputs N**, **Optical Digital 4 Input K** or the **Coaxial Digital 4 Input M** may be used to connect a device such as a video game or camcorder to your home entertainment system on a temporary basis.
- As the input source is changed, the new input name will appear momentarily as an on-screen display in the lower third of the video display (except when 720p or 1080i sources are in use). The input name will also appear in the **Upper Display Line 13** and in the front-panel **Input Indicators 11**.
- When an audio only source is selected, the last video input used remains routed to the **Video 1/Video Monitor Outputs 25 29**. This permits simultaneous viewing and listening to different sources.

6-Channel/8-Channel Direct Input

There are four input choices available for use with sources such as DVD-Audio SACD player or HD-DVD or Blu-Ray disc player that are connected to the **8-Channel Direct Inputs 39**. Select the appropriate input according to the way your system and source equipment is configured:

- The **6 CH DIRECT** input should be used when the SBR and SBL inputs are NOT in use and the input source device has its own internal bass management system. This input passes the input from the source directly through to the volume control without any analog-to-digital conversion, and it mutes the unused input jacks to prevent unwanted noise from interfering with system performance.
- The **6 CH DVD AUDIO** input should be used when the SBR and SBL inputs are NOT in use and when the input source does NOT have its own i

OPERATION

internal bass-management system. When this input is in use, the analog source is converted to digital so that you may use the same bass-management options for the direct input as are used for all other inputs. This input also mutes the unused input jacks to prevent unwanted noise from interfering with system performance.

- The **B CH DIRECT** input should be used when an input is connected to all eight **8-Channel Direct Inputs 49** and when the input source device has its own internal bass-management system. This input passes the input from the source directly through to the volume control without any analog-to-digital conversion.
- The **B CH DVD AUDIO** input should be used when an input is connected to all eight **8-Channel Direct Inputs 49** and when the input source does not have its own internal bass-management system. When this input is in use, the analog source is converted to digital so that you may use the same bass-management options for the direct input as are used for all other inputs.

Volume and Tone Control

- Adjust the volume to a comfortable level using the front-panel **Volume Control 10** or remote **Volume Up/Down Buttons 18 H**.
- To temporarily silence all speaker outputs, press the **Mute Button 45 S**. This will interrupt the output to all speakers and the headphone jack, but it will not affect any recording or dubbing that may be in progress. When the system is muted, the word **MUTE** will flash in the on-screen display (except when 720p or 1080i sources are in use) and **Upper Display Line 13**; press the **Mute Buttons 45 S** again to return to normal operation.
- The unit's tone controls may be taken out of the signal path by pressing the **Tone Mode Button C32**. The first button press will show a message in the on-screen display (except when 720p or 1080i sources are in use) and **Lower Display Line 14** with the current status of the tone controls. The system default is **TONE IN**, which indicates that the bass and treble controls are active. Press the **▲/▼ Navigation Buttons 14 G** on the remote control or the **◀▶ Buttons H** on the front panel to change the setting to **TONE OUT**, which is "flat" response without the tone controls being active.
- When the tone controls are active, the amount of bass and treble boost/cut may be adjusted up to ± 12 dB in 2dB steps by pressing the **Tone Mode Button C32** two or three times until the desired setting (**BASS MODE** or **TREBLE MODE**) appears in the on-screen display and in the **Lower Display Line 14**. Next, use the

◀▶ Navigation Buttons 14 G on the remote or the **◀▶ Navigation Buttons** on the front panel **H** to change the setting as desired. The unit will return to normal operation within five seconds after the setting is changed.

- For private listening, simply place a standard 1/4" stereo headphone plug or adapter into the **Headphone Jack B** behind the door **9** on the front panel. The speakers will automatically mute and a two-channel stereo signal will be sent to the headphones. The **Lower Display Line 14** will read **DOLBY H: BP**, indicating that the headphone output is in the Bypass mode, and to confirm that no processing is being used. To listen through the headphones using the Dolby Headphone mode, simply press the buttons on the remote or front panel as shown below for changing a Dolby mode. **DOLBY H: DH** will appear in the Lower Display Line when the Dolby Headphone mode is in use.

Surround Mode Selection

One of the most important features of the AVR 645 is its ability to reproduce a full multichannel surround sound field from digital sources, analog matrix surround-encoded programs and standard stereo programs.

Selection of a surround mode is based on personal taste, as well as the type of program source material being used. For example, motion pictures or TV programs bearing the logo of one of the major surround-encoding processes, such as Dolby Surround or DTS Stereo may be played in either the Dolby Digital, Dolby Pro Logic II Cinema, DTS Neo:6 Cinema, or Logic 7 Cinema surround modes, depending on the source material.

NOTE: Once a program has been encoded with matrix surround information, it retains the surround information as long as the program is broadcast in stereo. Thus, movies with surround sound may be decoded via any of the analog surround modes such as Dolby Pro Logic II Cinema, Logic 7 Cinema or DTS Neo:6 Cinema, when they are broadcast via conventional TV stations, cable, pay-TV and satellite transmission. In addition, a growing number of made-for-TV programs, sports broadcasts, radio dramas and music CDs are also produced in surround sound. You may view a list of these programs at the Dolby Laboratories Web site at www.dolby.com.

Even when a program is not listed as carrying intentional surround information, you may find that the Dolby Pro Logic II, Dolby Pro Logic IIx, Logic 7 or DTS Neo:6, and the Hall or Theater modes often deliver enveloping surround presentations through the use of the natural information present in all stereo recordings.

Surround modes may be changed at any time by using either the front panel or remote control. To

select a new surround mode from the front panel, first press the **Surround Mode Group Selector Button 2** until the desired major surround mode group such as Dolby, DTS or Logic 7 is selected. Next, press the **Surround Mode Selector Button 3** to choose the specific individual surround mode.

To choose a surround mode using the remote, first press the button for the major surround mode group that includes the mode you wish to select. These buttons are the **Dolby Mode Select Button 43**, the **DTS Digital Model Select Button 42**, the **DTS Neo:6 Mode Select Button 41**, the **DSP Surround Mode Select Button 7** and the **Stereo Mode Select Button 40**. The first press of a button will show the current mode from that group if it is already in use, or the first available mode if you are currently using another mode. To cycle through the available modes in that group, press the button again until the desired mode appears in the **Lower Display Line 14**, the on-screen display (when a 480i source is in use) and the front-panel **Surround Mode Indicators 15**.

The Dolby Digital, Dolby Digital EX, DTS 5.1, DTS-ES Matrix and DTS-ES Discrete modes may only be selected when a digital input is in use. In addition, when a digital source is present, the AVR 645 will automatically select and switch to the correct mode, regardless of the mode that has been previously selected. For more information on selecting digital sources, see the Digital Audio Playback section below.

When the 6-channel/8-channel direct inputs are in use, there is no surround processing, as these inputs take the analog output signals from an external source device and carry them straight through to the volume control without any further digital processing.

To listen to a program in traditional two-channel stereo, using the front left and front right speakers only (plus the subwoofer, if installed and configured), press the **Stereo Mode Select Button 40** until **SURROUND OFF** appears in the **Lower Display Line 14**. From the front panel, press the **Surround Mode Group Selector 2** until the **Stereo** modes appear in the on-screen display and **Lower Display Line 14**. Next, press the **Surround Mode Selector Button 3** until **SURROUND OFF** appears in the on-screen display and **Lower Display Line 14**.

Digital Audio Playback

Digital audio is a major advancement over older analog surround processing systems. It delivers up to six discrete channels, and each channel reproduces a full-frequency range (20Hz to 20kHz) and offers dramatically improved dynamic range and significant improvements to signal-to-noise ratios. In addition, digital systems have the capability to deliver an additional channel that is specifically devoted to low-frequency information. This is

OPERATION

the “.1” channel referred to when you see these systems described as “5.1,” “6.1” or “7.1.” The bass channel is separate from the other channels, but since it is intentionally bandwidth-limited, sound designers have given it that unique designation. When a digital soundtrack is playing, the number of channels available will vary according to the way in which the program was recorded. Although most movies recorded with digital sound have 5.1 soundtracks, some have 6.1 or 7.1 sound, while others retain the original two-channel or even monaural sound. When the program source is a broadcast, cable or satellite delivered digital program, only one type of soundtrack may be delivered at a time, while optical sources such as DVD may provide more than one audio option. In either case, the decision of what type of sound track and how many channels to offer is up to the program’s producer. With the AVR 645 you are able to not only play back the original compatible digital format, but using the processing power of the Texas Instruments DSP processor, it is possible to decode the basic digital track for 2.0 or 5.1 sound and then select an additional “post-processing” mode to deliver additional channels.

Dolby Digital

Dolby Digital is the default format for DVD discs and for the (ATSC) high-definition system used in the United States and Canada. It is also used by the digital satellite program services and is available on most digital cable set-top boxes. When the AVR 645 is connected to a blue-laser-based high-definition optical disc player via an HDMI, coaxial or optical digital connection, the soundtrack from the player may be available in the standard Dolby Digital or DTS format, so that it may be decoded by the AVR.

An optional, external RF demodulator is required to use the AVR 645 to listen to the Dolby Digital soundtracks available on laser discs. Connect the RF output of the LD player to the demodulator and then connect the digital output of the demodulator to the **Optical** or **Coaxial Inputs** **KIM** **37** **38** of the AVR 645. A demodulator is not required for use with high-definition optical disc or DVD players, or with DTS-encoded laser discs.

In order to provide maximum playback compatibility with DVDs, the AVR 645 receiver will always default first to the playback mode embedded in a disc’s digital “flag” information. For Dolby Digital discs, the following playback modes are initially selected after the AVR locks on to the incoming digital audio data stream:

- When a Dolby Digital 5.1 data stream is detected, the choice of which surround mode is activated is determined by the setting on the **DEFAULT SURR** line of the **SURROUND CONFIG** menu (Figure 21), as shown on page 26.

- When a disc with the Dolby Digital EX flag is played, your system will automatically switch to the EX mode when seven main speakers are available.
- When a disc with 2.0 Dolby Digital data is detected, the default mode is Dolby Digital with Pro Logic II postprocessing when you have a 5.1 speaker system, or Dolby Digital with Dolby Pro Logic IIx postprocessing when you have a 7.1 speaker system.
- Depending on the number of speaker channels available in your system, once the AVR locks on to the digital signal, you may select any surround mode or postprocessing option that is available, based on the incoming data stream’s possible restrictions and the number of speakers in your system. For example, when a 5.1 or 2.0 audio stream is in use, you may select alternate postprocessing such as Logic 7/7.1-channel Movie mode postprocessing to create the rear surrounds in 7.1 speaker systems.

DTS

DTS is another digital audio system that is capable of delivering 5.1 or 6.1 discrete or matrix sound field reproduction. Although both DTS and Dolby Digital are digital, they use different methods of encoding the signals, and thus they require different decoding circuits to convert the digital signals back to analog.

DTS-encoded soundtracks are available on select DVD and LD discs, as well as on special audio-only DTS discs. You may use any LD or CD player equipped with a digital output to play DTS-encoded discs with the AVR 645. All that is required is to connect the player’s output to either an **Optical** or **Coaxial Input** on the rear panel **37** **38** or front panel **KIM**.

In order to listen to DVDs encoded with DTS soundtracks, the DVD player must be compatible with the DTS signal, which is indicated by a DTS logo on the player’s front panel. Early DVD players may not be able to play DTS-encoded DVDs. If you are in doubt as to the capability of your DVD player to handle DTS discs, consult the player’s owner’s manual.

When the AVR 645 is connected to a blue-laser-based high-definition optical disc player via an HDMI, coaxial or optical digital connection, the soundtrack from the player is also available in the standard DTS format so that it may be decoded by the AVR.

NOTE:

- Some DVD players have a default setting that does not pass through the DTS signal. Before playing DVDs with a DTS soundtrack, make certain that the settings in your DVD player have been properly adjusted so that DTS audio is passed through. Consult the owner’s manual for your DVD player for more information on making these settings.

- When selecting surround modes, any mode where the setting in its mode group (Dolby, DTS, Logic 7, PCM, etc.) has been set to **OFF** in one of the **SURROUND CONFIG** menus will not appear. You may change the settings in this list at any time by following the instructions on page 26.

Selecting a Digital Source

To utilize either digital mode, you must have properly connected a digital source to the AVR 645. Connect the digital outputs from DVD players, HDTV receivers, satellite systems or CD players to the **Optical** or **Coaxial Inputs** **KIM** **37** **38**. In order to provide a backup signal and a source for analog stereo recording, the analog outputs provided on digital source equipment should also be connected to their appropriate inputs on the AVR 645 rear panel (e.g., connect the analog stereo audio output from a DVD to the **DVD Audio Inputs** **36** on the rear panel when you connect the source’s digital outputs).

If you have not already configured an input for a digital source using the on-screen menus, as shown on page 24, first select the input using the remote or front-panel controls, as outlined in this manual. Next, press the **Digital Select Button** **15**, then press the **Navigation Buttons** **14** **16** on the remote or the **Button** **H** on the front panel to choose any of the **OPTICAL** or **COAXIAL** inputs, as they appear in the **Upper Display Line** **13** or on-screen display. When the digital source is playing, the AVR 645 will automatically detect which type of digital data stream is being decoded and display that information in the **Upper Display Line** **13**.

When both a digital and an analog connection are made between a source device and the AVR, the digital input is the default. If the digital stream is not present or is interrupted, the unit will automatically switch over to the analog inputs for the selected source.

If you wish to disable the auto-polling feature, you may do so by following the instructions shown for the **IN/OUT SETUP** menu (Figure 2), as shown on page 24.

Digital Bitstream and Surround Mode Indications

When a digital source is playing, the AVR 645 senses the type of bitstream data that is present, and automatically selects the proper surround mode. For example, DTS bitstreams will cause the unit to switch to DTS decoding, and Dolby Digital bitstreams will enable Dolby Digital decoding. When the unit senses PCM data from CDs or LDs, you may select any of the standard Dolby or DTS surround modes or Logic 7. Since the range of available surround modes is dependent on the type of digital data that is present, the AVR 645 shows you what type of signal is present to help you understand the choice of modes.

OPERATION

When a digital source is first detected, the AVR 645 will display a message to indicate the type of bitstream being received. It will remain in the **Lower Display Line 14** for about 5 seconds before that portion of the display returns to the normal surround mode indication.

For Dolby Digital and DTS sources, a numerical indication (such as **3/2/2.1**) will appear, showing the number of channels present in the data.

The first number in the display message indicates how many discrete front-channel signals are present.

- A "3" tells you that separate front left, center and front right signals are available. This will be displayed for Dolby Digital 5.1, Dolby Digital EX and DTS 5.1 or DTS-ES programs.
- A "2" tells you that separate front left and right signals are available, but there is no discrete center channel signal. This will be displayed for Dolby Digital bitstreams that have stereo program material.
- A "1" tells you that there is only a mono channel available in the Dolby Digital bitstream.

The middle number in the display message indicates how many discrete surround channel signals are present.

- A "3" tells you that separate, discrete left surround, center surround and right surround signals are present. This is available only on discs with DTS-ES digital audio.
- A "2" tells you that separate surround left and right signals are available. This will be displayed for Dolby Digital 5.1 and DTS 5.1 programs.
- A "1" tells you that there is only a single, surround-encoded surround channel. This will appear for Dolby Digital bitstreams that have matrix encoding.
- A "0" indicates that there is no surround channel information. This will be displayed for two-channel stereo programs.

The last number indicates whether there is a discrete low-frequency effects (LFE) channel. This is the ".1" in the common abbreviation of "5.1" sound and it is a special channel that contains only bass frequencies.

- A ".1" tells you that an LFE channel is present. This will be displayed for Dolby Digital 5.1 and DTS 5.1 programs, as available.
- A "0" indicates that there is no LFE channel information available. However, even when there is no dedicated LFE channel, low-frequency sound will be present at the subwoofer output when the speaker configuration is set to show the presence of a subwoofer.
- The information on the right side of the display will tell you whether the digital audio data contains a

special flag signal that will automatically activate the appropriate 6.1 or 7.1 mode. This will be shown as EX-ON or EX-OFF for Dolby Digital bitstreams and ES-ON or ES-OFF for DTS bitstreams.

When a 2.0 or 5.1 digital source is playing on a system configured for 5.1 operation, you may use Dolby Digital EX, DTS-ES, Logic 7/7.1 or Dolby Pro Logic IIx to add rear channels for full 7.1 sound fields. Note, however, that the availability of specific modes for postprocessing is dependent on the format of the incoming source material. While some combinations (e.g., a Dolby Digital or DTS 5.1 source with Logic 7/7.1 or Dolby Pro Logic IIx postprocessing) are allowable, others (e.g., a Dolby Digital 5.1 source with DTS Neo:6) are not. If you wish to add surround back channels to a 2.0 or 5.1 source, we recommend that you experiment with the various options to see which may be available and which are best suited to your taste and listening environment.

It is always a good idea to check the readout for the channel data to make certain that it matches the audio logo information shown on the back of a DVD package. In some cases, you will see an indication for "2/0/0" even when the disc contains a full 5.1, or 3/2/1, signal. When this happens, check the audio output settings for your DVD player or the audio menu selections for the specific disc being played to make certain that the player is sending the correct signal to the AVR.

PCM Playback

PCM is the abbreviation for Pulse Code Modulation, the digital signal format used for standard CD playback, and other non-Dolby Digital and non-DTS digital sources such as MiniDisc. When a **PCM** signal is detected, the **Lower Display Line 14** will briefly show a message with the letters PCM, in addition to a readout of the sampling frequency of the digital signal.

In most cases, this will be **PCM 44.1kHz** or **PCM 48kHz**, though in the case of specially mastered, high-resolution audio discs, you will see a **PCM 96kHz** indication. Note that the sampling rate displayed is that of the incoming digital signal, and not the upsampled rate that may be applied to PCM sources when Dolby Pro Logic or Dolby Pro Logic II processing is applied, as shown on page 26.

During PCM playback, you may select any surround mode except Dolby Digital or DTS/DTS-ES mode.

USB Playback

The AVR 645 is among the very few A/V receivers capable of direct connection to a computer for audio playback. Once the AVR is connected, audio streams and playback are possible through your AVR, with all the power and performance of the high-current ampli-

er, your own speakers, and the enhanced multichannel playback made possible through the use of Logic 7, Dolby Pro Logic II/IIx or DTS Neo:6 processing.

The AVR 645's USB connectivity may be used with PC-compatible computers running either Microsoft® Windows® 2000 with Service Pack 4 or higher installed, or Windows XP or Windows XP Media Center Edition with Service Pack 1 or higher installed. Connect one of the available USB ports on your computer or a USB hub to the **USB Port 63** on the AVR using a cable with a standard USB plug on one side and a USB "Mini B" plug on the other side. You may use an optional cable available at most electronics and computer stores for this purpose.

In addition, you will need to have a media player installed on the computer. The AVR 645 has been tested for operation with Windows Media® Player Version 8.0 and above, but it is also compatible with many other popular players such as iTunes®, Winamp® and RealPlayer.® In most cases, it is best to always make certain that you have the latest version of the player installed to ensure the best compatibility.

When the connection between a computer and the AVR is made for the first time, or if the USB connection is plugged into a different USB port on a computer or hub that has not been previously connected to the AVR, you will see a series of pop-up messages from Windows to indicate that the computer is configuring itself for the new device. Since the AVR provides a number of different functions, you may see the "Found New Hardware" message up to four times, one each for "A/V Receiver," "Compatible Device," "Audio Receiver" and "Human Interface Device." When all messages have appeared and then cleared the screen, you are almost ready to begin.

Before selecting the USB input, first make certain that one of the media players listed above has been opened on the computer. Then you may select the USB input in any of the following ways:

- To select USB as a source from the front panel, press the **Input Source Selector Button 7** until USB appears as the input name in the **Upper Display Line 13** and in the semi-OSD display, if available. The **USB Input Source Indicator 11** will also light up on the front panel.
- To select USB as the input using the main remote, press the **Input Selector 5** with DMP printed on the button twice.
- To select USB as the input using the ZR 10 remote, press the **USB Input Selector D**.

When the USB input is selected and the AVR 645 is connected to a compatible computer with one of the media players mentioned above open, you may then use either remote's transport controls to start and stop

OPERATION

playback, as well as move to the next track. Activity of the Transport buttons may vary from one media player to another, but at the very least you will be able to use the Play and Stop buttons.

Once playback is started, the audio from a USB source is treated the same as any other two-channel audio source, and you may apply any of the appropriate surround processing modes. When playing back audio from a computer via the USB connection, the internal speakers in a laptop computer are often muted.

Speaker/Channel Indicators

In addition to the bitstream indicators, the AVR 645 features a set of unique channel-input indicators that tell you how many channels of digital information are being received and/or whether the digital signal is interrupted (Figure 23).

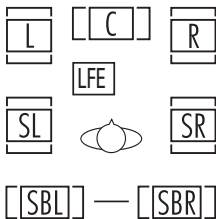

Figure 23

The letters inside the boxes tell you which channels are receiving an input signal. Since conventional analog audio is only two channels, the "L" and "R" letters will light with any analog source. When a digital source is in use, you will see letters displayed that correspond to the number of channels in the incoming data stream, which may be just the L and R for two-channel PCM or 2.0 Dolby Digital material. When a 5.1 signal is being received, the L/C/R/SL/SR indicators will light, with the LFE indication also being shown when an LFE signal is present. All seven indicators, including the SBL/SBR letters, will light for a 7.1 signal, and a horizontal line is shown to connect the SBL/SBR indicators when a 6.1 source is in use.

It is important to note that although Dolby Digital, for example, is referred to as a "5.1" system, not all Dolby Digital DVDs or programs are encoded for 5.1. Thus, it is sometimes normal for a DVD with a Dolby Digital soundtrack to trigger only the "L" and "R" indicators.

NOTE: Many DVD discs are recorded with both "5.1" and "2.0" versions of the same soundtrack. When playing a DVD, always be certain to check the type of material on the disc. Most discs show this information in the form of a listing or icon on the back of the disc jacket. When a disc does offer multiple soundtrack choices, you may have to make some adjustments to your DVD player (usually with the "Audio Select" button or in a menu screen on the disc) to send a full 5.1 feed to the AVR 645. It is also possible for the type of signal feed to change during the course of a DVD's

playback. In some cases, the previews of special material will only be recorded in 2.0 audio, while the main feature is available in 5.1 audio. The AVR 645 will automatically sense changes to the bitstream and channel count and reflect them in these indicators.

The letters used by the **Speaker/Channel Input Indicators** 12 will flash to indicate when a bitstream has been interrupted. This will happen when a digital input source is selected before the playback starts, or when a digital source such as a DVD is paused. The flashing indicators remind you that the playback has stopped due to the absence of a digital signal and not through any fault of the AVR 645. This is normal, and the digital playback will resume once the playback is started again.

The boxes around the channel indication letters are used to show which speakers are configured in your system. A small box around the letter indicates that a "Small" speaker has been assigned to that position, while a larger, double box indicates a "Large" speaker assignment.

Note that in some cases, such as an analog stereo or 2.0 digital sources you will see empty speaker position boxes, which indicates that the speaker is active and will receive sound, but that there is no discrete signal for that channel. In other cases you may see letters with no speaker boxes. This indicates that there is a discrete signal for that channel, but due to the mode in use (e.g., Dolby VS with a 5.1 source) there is no signal being sent to the channel.

Night Mode

A special feature of Dolby Digital is the Night mode, which enables specially encoded Dolby Digital input sources to be played back with full digital intelligibility while reducing the minimum peak level by 1/4 to 1/3. This prevents abruptly loud transitions from disturbing others, without reducing the impact of the digital source. The Night mode is available only when Dolby Digital signals with special data are being played.

The Night mode may be engaged at any time when a Dolby Digital source is playing by pressing the **Night Mode Button** 30. Each press of the button will change the Night mode setting, as shown in the lower third of the on-screen display (except when 720p or 1080i sources are in use). To turn the Night mode off, press the button as described, until **D-RANGE OFF** is shown.

The Night mode may also be selected to always be on at either level of compression using the options in the **DOLBY SURROUND** menu. See page 27 for information on using the menus to set this option.

IMPORTANT NOTES ON DIGITAL PLAYBACK:

- When playing DVDs, please note that even when you have selected a specific digital audio format for playback, an individual disc may change formats or the

number of available channels during playback. For example, even if you select a DTS mode for the movie, you may see Dolby Digital in use when the trailers, menus or copyright warnings are playing. This is not a fault with either the AVR or your DVD player, as both are responding to the way the disc was created.

- When viewing digital television signals, note that the number of audio channels available may vary during the course of a program, depending on the content. For example, while a sports event may have 5.1 sound, the commercials or local station content may be in 2.0. In addition, not all local stations are currently equipped for carrying the 5.1 digital audio signals. This may mean that even though the actual program is produced with 5.1, it may be transmitted in a 2.0 configuration in some areas. Your AVR will automatically change to react to the proper type of audio stream if it is changed by the broadcast station.
- Although the AVR 645 will decode virtually all current DVD movies, CDs and HDTV sources, it is possible that some future digital sources may not be compatible with the AVR 645.
- Not all digitally encoded programs contain full 5.1- or 6.1-channel audio. Consult the program guide that accompanies the DVD or laser disc to determine which type of audio has been recorded on the disc. The AVR 645 will automatically sense the type of digital surround encoding used and adjust to accommodate it.
- When a digital source is playing, you may not be able to select some of the analog surround modes such as Dolby Pro Logic II, Dolby Pro Logic IIx, Stereo, Hall, Theater or Logic 7.
- When a Dolby Digital or DTS source is playing, it is not possible to make an analog recording using the **Tape Outputs** 3 and **Video 1 Audio Outputs** 43. However, the digital signals will be passed through to the **Digital Audio Outputs** 34, 35, 36, 37, 38, 39, 40, 41, 42, 44, 45, 46, 47, 48, 49, 50, 51, 52, 53, 54, 55, 56, 57, 58, 59, 60, 61, 62, 63, 64, 65, 66, 67, 68, 69, 70, 71, 72, 73, 74, 75, 76, 77, 78, 79, 80, 81, 82, 83, 84, 85, 86, 87, 88, 89, 90, 91, 92, 93, 94, 95, 96, 97, 98, 99, 100.

Using The Bridge

The AVR 645 is equipped for use with Harman Kardon's optional **The Bridge** iPod docking station.

When The Bridge is connected to the AVR and an iPod properly docked, you may use either remote to control the iPod for audio playback while using the front-panel display and on-screen semi-OSD messages to help you locate tracks or view information about the track being played. In addition, connecting an iPod to the AVR 645 through The Bridge also charges the iPod's battery. Using the **DMP AUTO POWER** menu option, as described on page 45, you may even have the AVR 645 automatically turn on with your iPod as a playback source whenever the iPod is turned on.

OPERATION

To select The Bridge as the AVR's input source:

- From the front panel, press the **Input Source Selector 7** on the front panel as needed.
- From the main remote, press the **Input DMP Selector 4**.
- From the ZR 10 remote, press the **The Bridge / DMP Selector R**.

When The Bridge is connected and a compatible iPod properly docked, the iPod's menu will be replaced with "harman/kardon" at the top of the iPod's screen and the front-panel display and semi-OSD message will show messages that will guide you through the menu and content selection. If the **Lower Display Line 14** shows an **UNPLUGGED**... message, please check to see that the correct iPod adapter is used in The Bridge and that the iPod is properly seated.

The AVR's front-panel controls may also be used to access a limited number of iPod functions. Press the **Tuning Mode Button 8** to play or pause the current track. The **Tuning Selector 4** may be used to search in reverse (left side of button) or forward (right side of button) through the tracks. Press the **Tuner Band Selector 5** to call up the iPod's menu. Press the **Preset Station Selectors 6** to scroll and the **Set Button 1** to select. For complete information on using the remote or front-panel controls to operate an iPod, see the instructions that are included with The Bridge.

AM/FM Tuner Operation

The AVR 645's AM/FM tuner is capable of tuning AM, FM and FM Stereo broadcast stations. Stations may be tuned manually, or they may be stored as favorite station presets and recalled from a 30-position memory.

Tuner and Station Selection

The AVR 645's AM/FM tuner may be selected as the unit's source, and stations changed, by following one of these steps:

- From the front panel, press the **Input Source Selector 7** until the desired tuner frequency band (AM, FM or XM) appears. To change stations within a frequency band, press the **Tuning Selection 4**.
- You may also press the front panel's **Tuner Band Selector 5** to select the tuner. The first press will select the last used frequency band and station. Subsequent presses will change the frequency bands, selecting the last used station or XM program used. Press the **Tuning Selection 4** to change stations within a frequency band.
- From the main remote, press the **Tuner/FM Select Button 34** by pressing the button up towards the top of the remote. The first press of the button selects the frequency band and station or XM

channel that was last tuned. Press the button again to select between FM, AM and XM. You may also directly select the FM tuner by pressing the **Tuner/FM Select Button 34** down towards the bottom of the remote. To change stations, press the **Tuning Up/Down Button 23**.

- To select the tuner from the ZR 10 remote, press the **Tuner Selector E**, or for XM Radio press the **XM Radio Selector Button F** (when an optional XM Connect & Play or Passport module is connected and the programming service has been activated).
- To change the tuning mode, press the **Tuning Mode Button 8 12 O**.

When the button is pressed so that **AUTO / STEREO** appears in the **Upper Display Line 13**, each press will put the tuner in a scan mode that seeks the next higher or lower frequency station with acceptable signal strength. An **AUTO ST TUNED** indication will momentarily appear when the station stops at a stereo FM station, and an **AUTO TUNED** indication will momentarily appear when an AM or monaural FM station is tuned. Press the Tuning buttons again to scan to the next receivable station.

When the button is pressed so that **MANUAL / MONO** appears in the **Upper Display Line 13**, each tap of the Selector will increase or decrease the frequency by one increment. When the tuner receives a strong-enough signal for adequate reception, **MANUAL TUNED** will appear in the **Lower Display Line 14**.

- Stations may also be tuned directly in either the automatic or manual mode. To enter a station's frequency directly, first select the AM or FM band as shown above. Next, press the **Direct Button 9 M**. Within 5 seconds of when **DIRECT IN** scrolls in the **Upper Display Line 13**, enter the station frequency by pressing the **Numeric Keys 11 J**. If you press an incorrect button while entering a direct frequency, press the **Clear Button 10 L** to start over.

NOTE: When FM reception of a station is weak, audio quality will be increased by switching to Mono mode by switching to the **MANUAL / MONO** mode.

Preset Tuning

Using the remote, up to 30 AM or FM stations may be stored in the AVR 645's memory for easy recall, using the front-panel controls or the remote.

To enter a station into the memory, first tune the station using the steps outlined above. Then:

1. Press the **Memory Button 38 N**; the station's frequency will flash.

2. Within 5 seconds, press the **Numeric Keys**

39 J corresponding to the location where you wish to store this station's frequency. Once entered, the preset number will appear in the **Upper Display Line 13**.

3. Repeat the process after tuning any additional stations to be preset.

Recalling Preset Stations

- To manually select a station previously entered in the preset memory, press the **Numeric Keys 39 J** that correspond to the desired station's memory location.
- To manually tune through the list of stored preset stations one by one, press the **Preset Buttons 6 22** on the front panel or the main remote, or the **Prev/Next Transport Controls P** on the ZR 10 remote.

XM Radio Operation

XM Radio is a satellite-delivered service that offers hundreds of program channels, as well as local traffic and weather information for select cities. The AVR 645 is "XM Ready," which means that the unit is able to receive the XM service when an optional XM Connect and Play or Passport module is connected and the service activated. You may purchase the antenna module needed for XM Radio from many electronics or online retailers, or directly from XM Radio through the "Home Receivers" section of the XM Radio Store at www.xmradio.com.

Once you have purchased the XM module, follow the instructions accompanying it to activate the XM Service. Connect the plug on the XM module to the **XM Ready Module Input 22** on the rear panel of the AVR 645. For best results, point the antenna module out a window, again, following the instructions packed with the XM product. If a window view is not available for the antenna, XM Radio operates a series of terrestrial repeater stations that may be able to provide reception, though this service is not available everywhere.

IMPORTANT NOTE: XM Radio requires both the optional, external antenna module and a subscription to the XM Radio service. Antenna and service sold separately; XM Radio is not available in Alaska or Hawaii.

If you need to view the antenna module's number, connect it to the AVR and then follow one of the steps shown below to select XM Radio as the input source. Tune to "000" to get a readout of the number.

Once you have an activated module connected, follow one of these steps to select XM Radio as your system's audio source:

- From the front panel, press the **Input Source Selector 7**. If XM was the last-used tuner source,

OPERATION

it will appear; or press the button again until XM Radio is heard. Press the **Tuning Selector 4** to change stations within a frequency band. Press the **Tuning Selector 4** to select a different XM channel.

- From the main remote, press the **Tuner/FM Select Button 34** by pressing the button up towards the top of the remote as needed until XM Radio is shown as the source. To change stations, press the **Tuning Up/Down Button 23**.
- To select the tuner from the ZR 10 remote control, press the **XM Radio Selector Button F**. Channels are selected using the **Prev/Next Transport Controls P**.

While using XM Radio is similar in many ways to AM/FM terrestrial radio, the wide range of program choices available, as well as the ability of the XM service to add special data and information tags into the digital audio data stream, means that some of the front-panel and remote controls traditionally used for tuner operation have different functions with XM Radio.

- When XM Radio is the AVR's source, the channel number will appear in the **Upper Display Line 13**, along with an indication of the Preset number, if any, and a series of bars at the far right end of the display. These bars (not shown in the semi-OSD message), show the current signal strength similar to the signal strength displays on a cellular phone.
- The current channel's name will normally appear in the **Lower Display Line 14**. For local traffic information, the name of a city will be shown in place of the channel name. You may change this display to show the current artist and track title information by pressing the **Tuning Mode Selector 8 12 O**. When you are listening to a channel with local traffic information in the "200" series of channel numbers, these buttons change the display to show the temperature and current weather for the selected city.
- To tune a channel number directly, simply press the **Numeric Keys 39 J**. Unlike standard AM/FM tuner operation, it is not necessary to press the Direct button first.
- The AVR 645 has five banks of preset memories for XM Radio, each with eight memory positions and designated by a letter ("A" through "E"). To store a channel into a memory group, first press the **Set Button 16 Q** until **PRESET SEARCH** appears in the **Upper Display Line 13** and on the top line of the semi-OSD display. Next, press the **Navigation Buttons 14 G** until the desired preset memory bank letter appears in the **Lower Display Line 14** and in the bottom line of the semi-OSD display. Next, press the **Memory Button 38 N** and note that a dash will start to flash next to the preset memory bank

letter. Within five seconds, press the **Numeric Button 39 J** from 1 to 8 for the memory slot you wish to use.

- To tune up or down through a list of channels stored in the currently active preset memory, press the **Preset Up/Down Buttons 22**. You may also use the **Preset Station Selector 6** on the front panel, or the **Prev/Next Transport Controls P** on the ZR 10 remote. To change to another preset bank, press the **Set Button 16 I Q** and then press the **Navigation Buttons 14 G** until the desired preset memory bank letter appears in the **Lower Display Line 14** and in the bottom line of the semi-OSD display.
- Each XM Radio channel is assigned a category, which may be viewed by pressing the **Tuning Mode Selector 12 8 O**. You may search for an XM channel in any of the categories by first pressing the **Set Button 16 I Q** and then pressing the **Navigation Buttons 14 G** until the desired category name appears in the **Lower Display Line 14** and in the bottom line of the semi-OSD display. Press the **Set Button 16 I Q** again to start the search for the next channel in that category.
- Note that you may see a **LOADING** message, indicating that the XM tuner is downloading content and may not be able to operate. If the message continues to appear, check to see whether the XM antenna is properly positioned toward a south-facing window, experiment with the antenna position, or change to another input and then reselect XM Radio.

Recording

In normal operation, the audio or video source selected for listening through the AVR 645 is sent to the record outputs. This means that any program you are watching or listening to may be recorded simply by placing machines connected to the outputs for **Tape Outputs 3** or **Video 1 Audio and Video Outputs 29 43** in the record mode.

When a digital audio recorder is connected to the **Digital Audio Outputs 34 35 M**, you are able to record the digital signal using a CD-R, MiniDisc or other digital recording system.

NOTES:

- The digital outputs are active only when a digital signal is present, and they do not convert an analog input to a digital signal, or change the format of the digital signal. In addition, the digital recorder must be compatible with the output signal. For example, the PCM digital input from a CD player may be recorded on a CD-R or MiniDisc, but Dolby Digital or DTS signals may not.

- The **Front-Panel Video 4 N** and **Coaxial 4 M** jacks may be configured for use as outputs, allowing connection to a recorder, when the steps shown in the section below are followed.
- Please make certain that you are aware of any copyright restrictions on any material you copy. Unauthorized duplication of copyrighted materials is prohibited by federal law.

Front-Panel Connections

In addition to the rear-panel digital and analog outputs, the AVR 645 offers Harman Kardon's exclusive configurable front-panel output-jack feature. For easy connection of portable devices, you may switch the front-panel **Video 4 Jacks N** or the **Coaxial Digital 4 Jack M** from an input to an output by following these steps:

1. Press the **OSD Button 31 B** to view the **MASTER MENU** (Figure 1).
2. Press the **Set Button 16 Q** to enter the **IN/OUT SETUP** menu (Figure 2).
3. Press the **Navigation Button 14 G** so that the on-screen cursor is next to **VIDEO 4** or **COAXIAL 4**.
4. Press the **Set Button 16 Q** and then press the **Navigation Buttons 14 G** so that the word **OUT** is highlighted.
5. Press the **Set Button 16 Q** to enter the change.
6. Press the **OSD Button 31 B** to exit the menus and return to normal operation.

Once the setting is made, the **Input/Output Status Indicator L** will turn red, indicating that the jacks are now outputs, instead of in the default setting as inputs. Once changed to an output, the setting will remain as long as the AVR 645 is turned on, unless the setting is changed in the OSD menu system, as described above. However, once the AVR 645 is turned off, the setting is canceled. When the unit is turned on again, the front-panel jacks will return to their normal default setting as inputs. If you wish to use the jacks as outputs at a future time, the setting must be changed again using the OSD menu system, as described above.

Output Level Trim Adjustment

Normal output level adjustment for the AVR 645 is established using EzSet/EQ, as outlined on pages 27–30. In some cases, however, it may be desirable to trim the output levels using program material such as a test disc, or a selection you are familiar with. Additionally, the output level for the subwoofer can only be adjusted using this procedure.

To adjust the output levels using program material, first set the reference volume for the front left and front right channels using the **Volume Control** **10** **18** **H**.

Once the reference level has been set, press the **Channel Select Button** **13** **E** and **FRONT LEVEL** will appear in the **Lower Display Line** **14**.

To change the level, first press the **Set Button** **11** **16**, and then use the **▲/▼ Navigation Buttons** **H** **14** to raise or lower the level. DO NOT use the volume control, as this will alter the reference setting.

Once the change has been made, press the **Set Button** **11** **16** and then press the **▲/▼ Navigation Buttons** **H** **14** to select the next output-channel location that you wish to adjust. To adjust the subwoofer level, press the **▲/▼ Navigation Button** **H** **15** until **W O O F E R LEVEL** appears in the **Lower Display Line** **14** or on-screen display.

Repeat the procedure as needed until all channels requiring adjustment have been set. When all adjustments have been made and no further adjustments are made for 5 seconds, the AVR 645 will return to normal operation.

The output levels may also be adjusted using the on-screen menu system to either the internal test tone or an external test disc by following the instructions shown on page 33.

EzSet/EQ On/Off

If you wish to turn the filter settings established by EzSet/EQ on or off to demonstrate the impact EzSet/EQ has on the sound of your system, simply press the **EzSet/EQ On/Off button** **11**. Using this feature does not change the settings; it merely puts them in or out of the signal path.

Dim Function

Since the AVR 645 will often be used when movies or other kinds of video programming are viewed under low-light conditions, you may wish to lower the brightness of the front-panel displays and indicators so that they do not distract from the video presentation. You may dim the displays using the menu system, as shown on page 44, or you may control the brightness directly from the remote.

Simply press the **Dim Button** **33** once to dim the front panel to half the normal brightness level; press it again to turn the displays off. Note that when the displays are dimmed or turned off, the blue lighting around the **Standby/On Switch** **1** will continue to stay lit as a reminder that the AVR is still turned on. The accent lighting for the **Volume Control** **10** will remain at its normal level, rather than dim when the

panel displays are at half-brightness.

Note that all changes to the front-panel brightness level are temporary; the displays will return to full-brightness after the AVR is turned off and then on again. To return the displays to full-brightness without turning the unit off, press **Dim Button** **33** as needed until the displays are on.

In addition to lowering the brightness of the displays or turning them off completely, you may wish to have them appear whenever a button on the remote or front panel is pushed, and then gradually fade out after a set time period. You may do this by making the appropriate settings in the **VFD FADE TIME OUT** line of the **ADVANCED SELECT** menu, as shown on page 44.

Memory Backup

This product is equipped with a memory backup system that preserves the system configuration information and tuner presets if the unit is accidentally unplugged or subjected to a power outage. This memory will last for at least four weeks, after which time all information must be reentered.

TROUBLESHOOTING GUIDE

SYMPTOM	CAUSE	SOLUTION
Unit does not function when Main Power Switch is pushed	<ul style="list-style-type: none"> No AC Power 	<ul style="list-style-type: none"> Make certain that AC power cord firmly connected to the AC Power Cord Socket 19 and is plugged into a live outlet Check to see whether outlet is switch-controlled
Display lights, but there is no sound or picture	<ul style="list-style-type: none"> Intermittent input connections Mute is on Volume control is down 	<ul style="list-style-type: none"> Make certain that all input and speaker connections are secure Press Mute Button 45 S Turn up volume control
Unit turns on, but front-panel display does not light up	<ul style="list-style-type: none"> Display brightness is turned off 	<ul style="list-style-type: none"> Follow the instructions in the Display Brightness section on page 44 so that the display is set to VFD FULL
No sound from any speaker; light around power switch is red	<ul style="list-style-type: none"> Amplifier is in protection mode due to possible short Amplifier is in protection mode due to internal problems 	<ul style="list-style-type: none"> Check speaker wire connections for shorts at receiver and speaker ends Contact your local Harman Kardon service center
No sound from surround or center speakers	<ul style="list-style-type: none"> Incorrect surround mode Input is monaural Incorrect configuration Stereo or Mono program material 	<ul style="list-style-type: none"> Select a mode other than Stereo There is no surround information from mono sources Check speaker mode configuration The surround decoder may not create center- or rear-channel information from nonencoded programs
Unit does not respond to remote commands	<ul style="list-style-type: none"> Weak batteries in remote Wrong device selected Remote sensor is obscured 	<ul style="list-style-type: none"> Change remote batteries Press the AVR selector Make certain front-panel sensor is visible to remote or connect remote sensor
Intermittent buzzing in tuner	<ul style="list-style-type: none"> Local interference 	<ul style="list-style-type: none"> Move unit or antenna away from computers, fluorescent lights, motors or other electrical appliances
Letters flash in the channel indicator display and digital audio stops	<ul style="list-style-type: none"> Digital audio feed paused 	<ul style="list-style-type: none"> Resume play for DVD Check that Digital Input is selected
Fan does not appear to operate	<ul style="list-style-type: none"> Additional cooling may not be required 	<ul style="list-style-type: none"> The fan is activated only when additional cooling is required due to high internal temperature, it is normal for the fan to be inactive at normal volume levels

In addition to the items shown above, additional information on troubleshooting possible problems with your AVR 645, or installation-related issues, may be found in the list of "Frequently Asked Questions" which is located in the Product Support section of our Web site at www.harmankardon.com.

Processor Reset

In the rare case where the unit's operation or the displays seem abnormal, the cause may involve the erratic operation of the system's memory or microprocessor.

To correct this problem, first unplug the unit from the AC wall outlet and wait at least 3 minutes. After the pause, reconnect the AC power cord and check the unit's operation. If the system still malfunctions, a system reset may clear the problem.

To clear the AVR 645's entire system memory including tuner presets, output level settings, delay times and speaker configuration data, first put the unit in the

Standby Mode by pressing the **Standby/On Switch 1**. Next, press and hold the **Surround Mode Group Selector 2** and the **Tuning Mode Selector 3** buttons for 3 seconds.

The unit will turn on automatically and display the **RESET** message in the **Upper Display Line 13**.

NOTE: Resetting the processor will erase any configuration settings you have made for speakers, output levels, surround modes, and digital input assignments, as well as the tuner presets. After a reset, the unit will be returned to the factory presets, and all settings for these items must be reentered.

If the system is still operating incorrectly, there may have been an electronic discharge or severe AC line interference that has corrupted the memory or microprocessor.

If these steps do not solve the problem, consult an authorized Harman Kardon service center.

MRK	DATE	PNO	REVISION RECORD	DR.	MAK	DATE	PNO	REVISION RECORD	DR.
▲					▲				
▲					▲				
▲					▲				

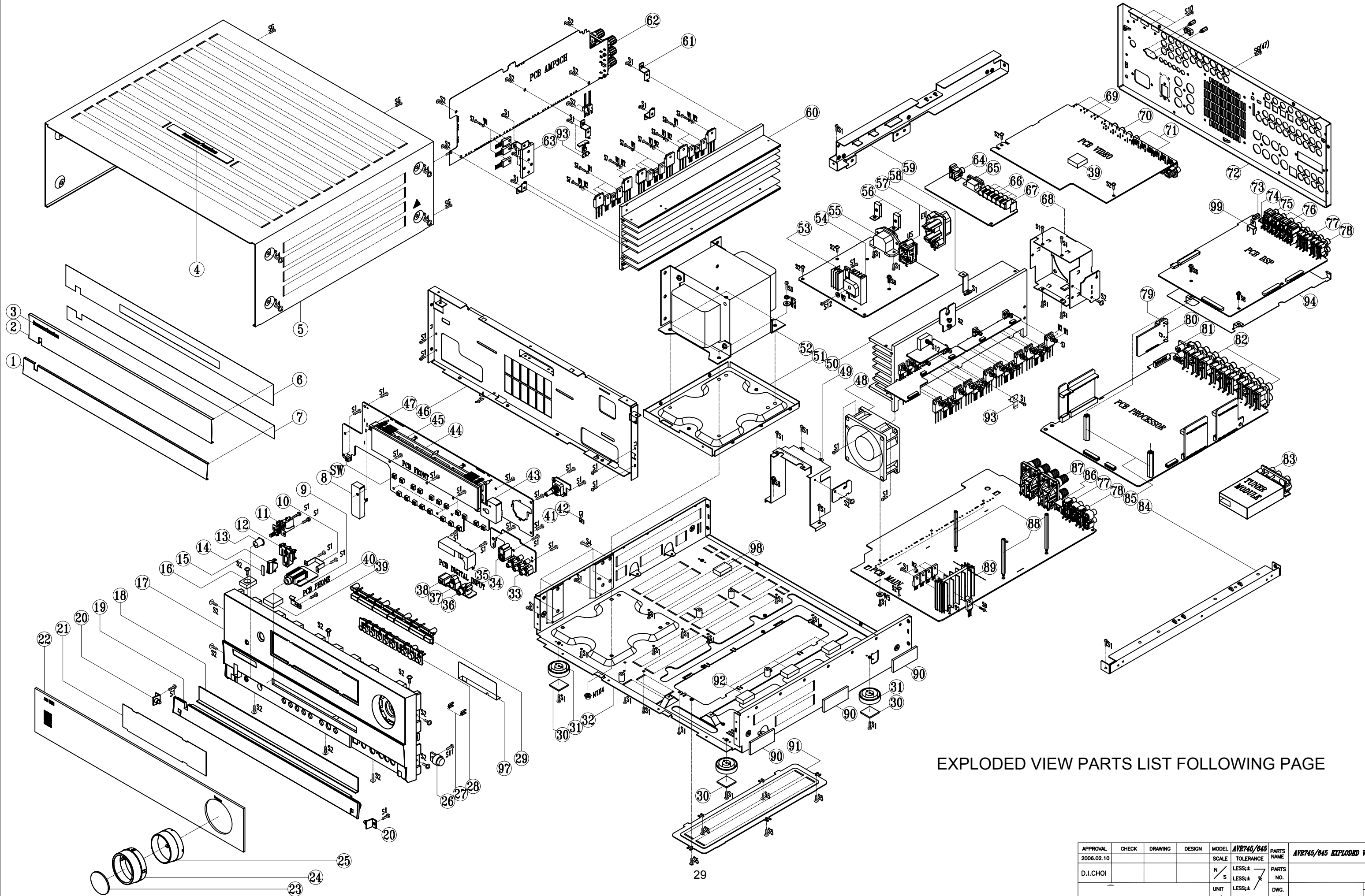

EXPLODED VIEW PARTS LIST FOLLOWING PAGE

APPROVAL	CHECK	DRAWING	DESIGN	MODEL	SCALE	TOLERANCE	PARTS NAME	PARTS NO.	DWG. NO.	REV.
2006.02.10				AVR745/045	N/S	LESS:±	AVR745/045 EXPLODED VIEW			
D.I.CHOI						LESS:±				
						UNIT				
						m/m				

AVR645 US/EU EXPLODED VIEW PARTS LIST				
		PART NO.		DESCRIPTION
#	645 US	645EU		QTY
1	H03-ZMC11S00200		AL DOOR AVR	1
2	H03-ZMD2702GAGY		AL PANEL FRONT AVR	1
3	H03-ZMD2703GAGY		BADGE FRONT AL AVR GREY HOT STAMPING	1
4	H03-ZMD27S20A00		BADGE harman/kardon COVER TOP AVR	1
5	H03-ZMD27S08A00		COVER TOP AVR	1
6	H03-ZVC11DWT200		TAPE PANEL	1
7	H03-ZVC11DWT100		TAPE DOOR	1
8	H03-ZMD12S01A00		SHIELD IR	1
9	H03-SOSS9CKX3NN		JACK PHONE 6.35 H70980110S 9P BK	1
10	H03-ZMB01S00100		BKT HEADPHONE	1
11	H03-SWA2B21PDA&		SW PUSH POWER SDDL15700	1
12	ZPC1006GAWH		BUTTON STANDBY	1
13	ZPC1003GAGY		BUTTON POWER	1
14	ZPC1007GAMW		INDICATOR STAND-BY	1
15	H03-ZMC11S12A00		CAP BUTTON STAND-BY AVR	1
16	ZFD122062SB		RUBBER TOP AVR	1
17	ZPD2701GAGY		PANEL FRONT AVR - USA	1
17	---	ZPD2801GAGY	PANEL FRONT AVR - 230V	1
18	H03-ZMC11S14A00		BRACKET DOOR	1
19	ZPC1002GAGY		DOOR AVR	1
20	H03-ZMD05S16A00		BKT HINGE AVR	2
21	H03-ZPC1018GART		FILTER VFD	1
22	H03-ZPD2919GABT		WINDOW DISPLAY AVR645+BADGE NAME	1
23	H03-ZPD0317GACR		CAP KNOB VOLUMN	1
24	H03-ZPD0316GASG		COVER KNOB	1
25	H03-ZPD0315GAMW		VOLUMN KNOB	1
26	H03-ZVC11GEAR01		DAMPER GEAR DP120	1
27	ZPC1102GAMW		INDICATOR VIDEO	2
28	ZPC1005GAGY		BUTTON 8 KEY	1
29	H03-ZPC1004GASG		BUTTON 7 KEY	1
29	---	H03-ZPD1004GASG	BUTTON 7 KEY EU	1
30	ZFNR19720SB		RUBBER FOOT 19.7X19.7X2T BK	4
31	ZPC1103GAGY		FOOT 50MM 15.8MM	4
32	H03-ZMD27S13A00		CHASSIS MAIN AVR	1
33	H03-SORA3313PNN		CON PHONOSCKT RCA-313P3PINS	1
34	H03-SORA8OSC5N8		JACK S-VIDEO 1P C40160261N	1
35	H03-ZMC12S17A00		AC PUN SHIELD DIGITAL ET	1
36	H03-SORA1JE01NN		JACK RCA 1P JE010003MN GND OR	1
37	H03-SOTORX177LT		FIBER OPTIC RECEIVING TORX177L (F, T)	
38	H03-SO3P5179NNN		JACK PHONE 3.5PI PJ0435179N	1
39	ZFD122072SB		RUBBER TOP AVR	3
40	H03-ZMC11S06A00		SPRING STOPPER AVR430/630	1
41	H03-SWE3A0505S1		SWIROT EC 16B24204A9 5V 500UOA 10T 3P 00	1
42	H03-ZMB01S02200		SPRING PLATE GND C5212 0.2T	9
43	H03-ZMD12S01B00		SHIELD MICROPHONE	1
44	H03-XD18BT19GNA		VFD 18-BT-19GINK	1
45	ZPC1017GABK		HOLDER VFD AVR	1
46	H03-ZMC11S07A00		CHASSIS FRONT AVR	1
47	H03-ICROMN338EC		REMOCON RECEIVER MODULE ROM-N338TEC	
48	H03-ZVJF0925S00-R-0		DC FAN JF0925S1M-003C651R 12V 92x92x25mm	
49	H03-ZMC11S09A00		BKT FAN FRONT AVR	1
50	H03-ZMD27HS0200		H/SINK MAIN AVR745	1
51	H03-ZMC12S08B00		BKT TRANS BOTTOM	1

52	H03-TXPWMEI95B0		PWR TRANSFORMER AVR645 MAIN 120V 60Hz	1
52	---	H03-TXPWMEI93B0	PWR TRANSFORMER AVR645 MAIN 230V 50Hz	1
53	H03-ZMC12HS0100		AC HEATSINK 17x15x30 AVR--ME	1
54	H03-ZMC11HS0400		HEATSINK DIODE 47x26x12 AVR	1
55	H03-SOXA27014NN		CON MAINS INLETAIC A/C INLET7014-NGP	1
56	H03-ZMC12S19A00		BKT AC INLET	2
57	H03-SOXA2202DNN		A202D0031P 2P	1
57	---	H03-SOXA0302DNN-R-3	A302D0061P AC Out Let (1P)	1
58	H03-ZMD27S06A00		BKT VIDEO	1
59	H03-ZMD27S04A00		BKT FRAME GUIDE AVR	1
60	H03-ZMD27HS0100		H/SINK AMP AVR	1
61	H03-ZMC12S09A00		BKT HEATSINK	5
62	H03-SOPA8SH0612		JACK SPEAKER 6P SH0612707P GN BN TA	1
63	H03-ZMD27HS0300		HEATSINK AMP SMALL	1
64	H03-SORA10003GN		JACK RCA 1P JE010003SG GND YELLOW GOCD CO	1
65	SOPA96063NN		JACK D-SUB 9P 87204-6063 W/DUST COVER BK	1
66	H03-SOJW2350SNN-R-7		JACK PHONE 3.6 EP-1401A 1P BK	5
67	H03-ZMC12S16A00		BKT GROUND	1
68	H03-ZMC11S10A00		BKT FAN REAR AVR	1
69	H03-SOYKF457009		JACKI HDMI YKF45-7009 JALCO	3
70	H03-SOR12BJ12NN		JACK RCA 12P BJ120154JN R4 BU4 G4	1
71	H03-SORA60031YN		JACK RCA+S-VIDEO 6P C8030031YN	2
72	H03-ZMD29S02A00		PANEL REAR AVR645US	1
72	---	H03-ZMD30S02A00	PANEL REAR AVR645EU	1
73	H03-SOUSB45810B		JACK R41-5810B (Mitsumi) XM/DT connector	1
74	H03-SOUSB5005K0		AU6-EC-005K0	1
75	H03-SOTX220750N		JACK RCA+OPTICAL TX YKC22-0750N	1
76	H03-SORX220751N		JACK RCA+OPTICAL RX YKC22-0751N	1
77	H03-SORA40RSANN		JACK RCA 4P JB040131ZN GN,BN,PP,TA	1
78	H03-SORA40RSCNN		JACK RCA 4P JB040131QN WH,BU,RD,GY	1
79	H03-ZMD27S05A00		BKT IPOD	1
80	H03-SO1R018H91E		DA1R018H91E	1
81	H03-SORA1J440GE		JACK RCA 1P PPJ-440FEG PP GOLD COLOR	1
82	H03-SORA64105NN		JACK RCA 6P JB060132PN WWWRRR	3
83	H03-ZVC11TUNE01		TUNER MODULE KST-MB011MW0-81 US	1
83		H03-ZVD01TUNE00	TUNER MODULE KST-MB114MW1-81 OEM EU	1
84	H03-ZMC11S04B00		BKT FRAME-GUIDE	1
85	ZMC12S13AYE		STANDOFF HEX M4x0.7 6x31.9H	2
86	SO0A18P8CNN		JACK-TELE SNAPG-IN GDLDEN TELECOM 1-8P8C 8T BK	1
87	H03-SOPA81900NN		CONN-SPE TERMINAL SPKR 8P SH081136JP FE 19MM 8 - 00	1
88	ZMC12S14AYE		STANDOFF HEX M4X0.7 6X61.9H	3
89	H03-ZMD27HS0400		H/SINK REG. TR AVR	1
90	ZFNR13830SB		RUBER SIDE	6
91	H03-ZMC12S07A00		COVER BOTTOM	1
92	ZUC1201AABK		SPONGE 30X30X10T BK	3
93	H03-ZMD2701ZANI		BRACKET POSISTOR,METAL,AVR	2
94	H03-ZMD12S01C00		SHIELD DSP AVR	1
95	---		BKT HDMI AVR	1
96	---		SPEAKER TERMINAL KNOB CORK B3M790BO	14
97	H03-ZMD27S07A00		SHIELD AL	1
98	H03-ZUD0301ABBK		SPONGE-UL 30X30X12T BK	1
99	H03-ZMD27S09A00		BRACKET BKT XM	1
SW	H03-SWC2A112FS1		SWITCH VERTICAL SKQNADD010	20

N1	ZNSSM4045HZ		NUT M4 HEXAGON CIRCULAR EXTERNAL	4
N2	ZNSSM3023HZ		NUT M3 ZN PLATED	1
S1	ZSTBM3010BB		SCREW ST BH 3X10	64
S2	ZSTWM3008BY		SCREW ST WPH 3X8	45
S3	ZSMCM4010BB		SCREW BM 4X10	4
S4	ZSTWM4008BC		SCREW ST WPH 4X8 SILVER CHROM	14

S5	ZSTWM3006BB		SCREW ST WPH 3X6	7
S7	ZSTBM3012BY		SCREW ST BH 3X12 PIVOT	43
S8	ZSMCM4008BY		SCREW BM 4X8	5
S9	ZSMBM3014BZ		SCREW M.S M3X14 ZN PLATED	1
S10	ZSMPM3006LB		SCREW M.S.M3X6 P/HD BLACK	3
S11	ZSTBM3008BY		SCREW ST BH 3X8	1
S12	ZSTBM3014BY		SCREW ST BH 3X14 PIVOT	1
SG	ZSTGM3010BB		SCREW ST BH 3X10 GROUND	51
W1	ZWM623108SZ		WASHER SPRING 3	42
W2	ZWM803305PZ		WASHER PLAIN 3	19
W3	ZWM763109SZ		AC SPRING WAS HER RT2250(PAV5005)	4
W4	ZWMC04810PZ		WASHER PLAIN 4	4

SERVICE PROCEDURE

ALIGNMENT PROCEDURES

1.MAIN AMP idling Adjustment

SET CONDITION

- 1) SEMI VOLUME POSITION at MAIN/SURROUND AMP Board
 MAIN:VR71.VR72
 SURROUND:VR73.VR74

 NO Signal/No Load
 AC Line Voltage:120V/60Hz.230V/50Hz
- 2) After turning on the unit keep it over than 25min (keep the power/Driver TR as normal temperature)
- 3) Adjust the voltage value of primary&secondary of wafer to be 25mV by rotating the semi volume of each channel to the right

CHANNEL	ADJUSTMENT	MEASUREMENT	VOLTAGE
FRONT-L CH	VR71	P817	23+/-2mV
FRONT-R CH	VR72	P805	23+/-2mV
SURROUND-L CH	VR73	P818	23+/-2mV
SURROUND-R CH	VR74	P806	23+/-2mV

- 4) CAUTION
 In case that power TR or DRIVER TR is needed to be replace for repairing the corresponding channel should be adjusted again

 FRONT AMP:Q437.Q433.Q435.Q439.Q438.Q434.Q436.Q440
 SURROUND AMP:Q333.Q329.Q331.Q335.Q334.Q330.Q332.Q336

2.SURROUND BACK AMP idling Adjustment

SET CONDITION

- 1) SEMI VOLUME POSITION at CENTER/SURROUND BACK AMP Board
 CENTER:VR501
 SURROUND BACK:VR201.VR301

 NO Signal/No Load
 AC Line Voltage:120V/60Hz.230V/50Hz
- 2) After turning on the unit keep it over than 25min (keep the power/Driver TR as normal temperature)
- 3) Adjust the voltage value of primary&secondary of wafer to be 25mV by rotating the semi volume of each channel to the right

CHANNEL	ADJUSTMENT	MEASUREMENT	VOLTAGE
CENTER	VR501	P501	23+/-2mV
SURR BACK-L CH	VR201	P201	23+/-2mV
SURR BACK-R CH	VR301	P301	23+/-2mV

- 4) CAUTION
 In case that power TR or DVIER TR is needed to be replace for repairing the corresponding channel should be adjusted again

 CENTER AMP:Q519,Q517.Q516,Q518
 SUR BACK AMP:Q319.Q317.Q316.Q318.Q219.Q217.Q216.Q218

3.Cautions for main adjustment

- 1) At MAIN/SUPPLY BOARD.use the below capacitor after discharging for sufficient time for preventing possible damage from electrical spark

MAIN BOARD	C571.C572	AVR745/645 15000/63V
	C571.C572	AVR445 12000/63V
SUPPLY BOARD	C201,C202	AVR745/645 10000/63V
	C201,C202	AVR445 8200/63V

- 2)The checking for MAIN/SUPPLY BOARD should have the discharging circuit discharge over 30sec.through(4R70hm 10W)resistor after push power sw off

Alignment and test position (MAIN AMP BOARD)

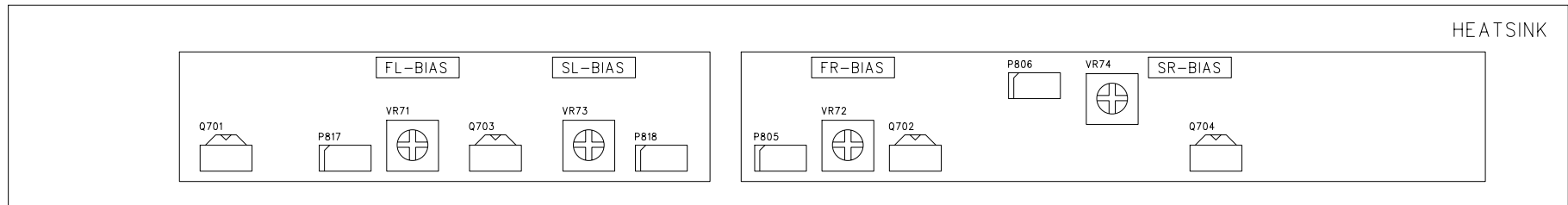
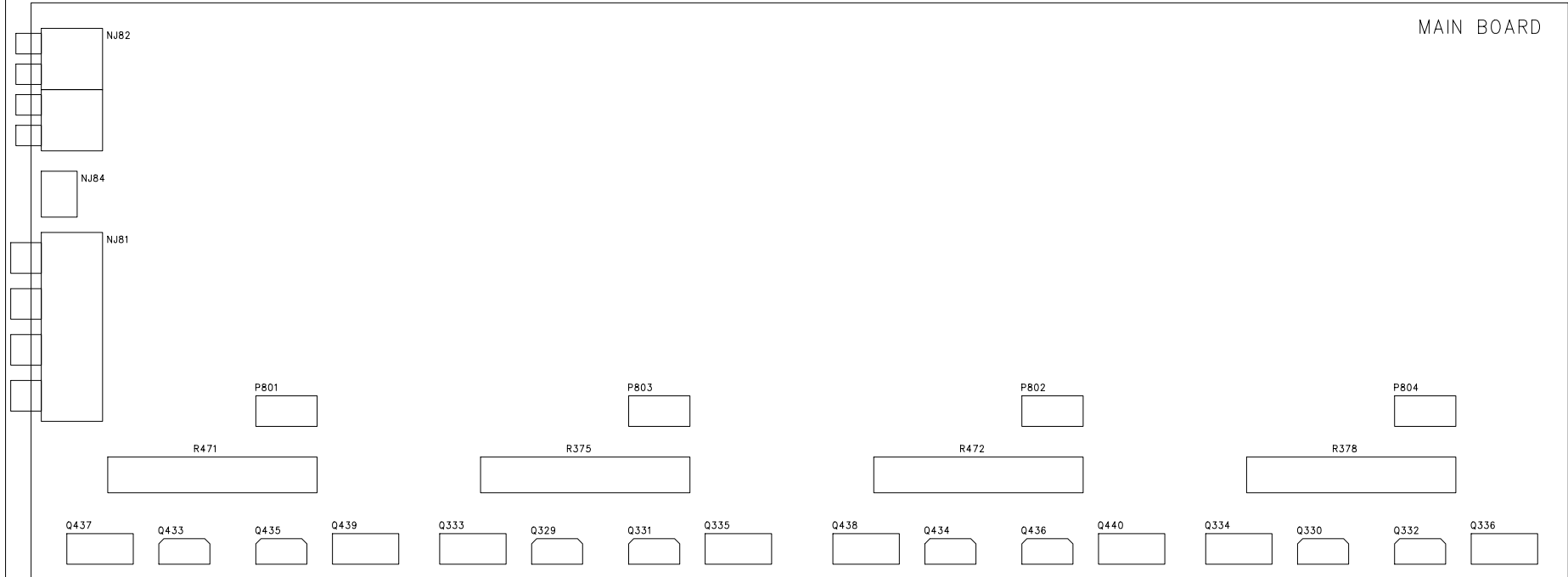

Alignment and test position (SURROUND BOARD)

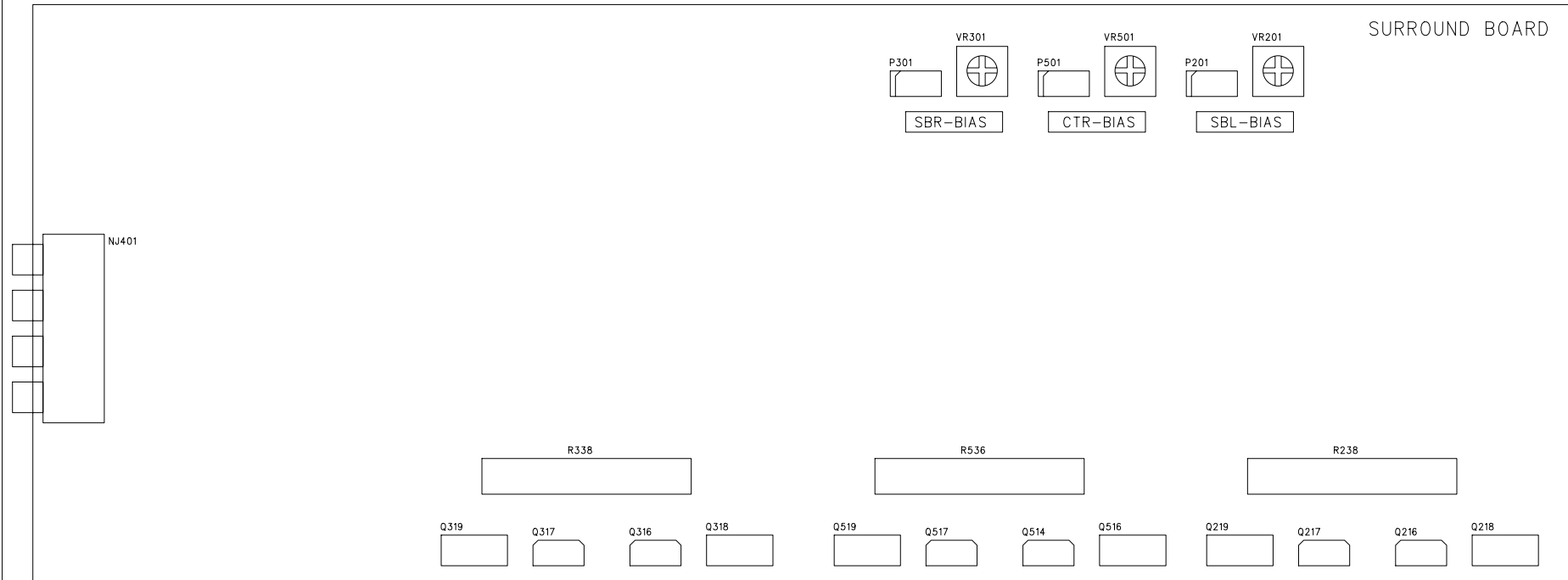

AVR645 BLOCK DIAGRAM

REVISION RECORD		
NO.	Date	Contents

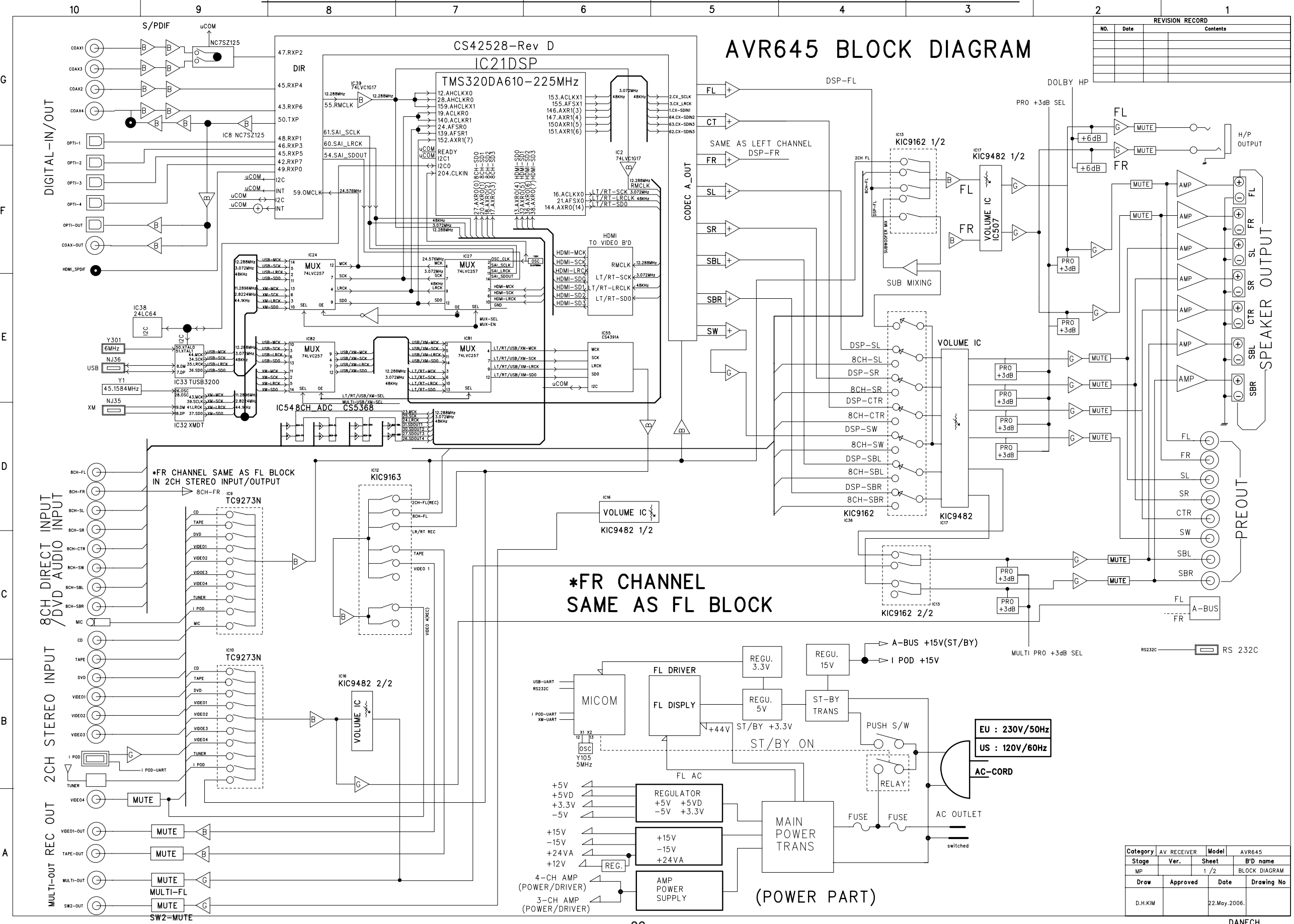

***FR CHANNEL SAME AS FL BLOCK**

***FR CHANNEL SAME AS FL BLOCK IN 2CH STEREO INPUT/OUTPUT**

(POWER PART)

Category	AV RECEIVER	Model	AVR645
Stage	Ver.	Sheet	B'D name
MP		1 / 2	BLOCK DIAGRAM
Draw	Approved	Date	Drawing No
D.H.KIM		22.May.2006.	

AVR645/445-CIRCUIT DESCRIPTION

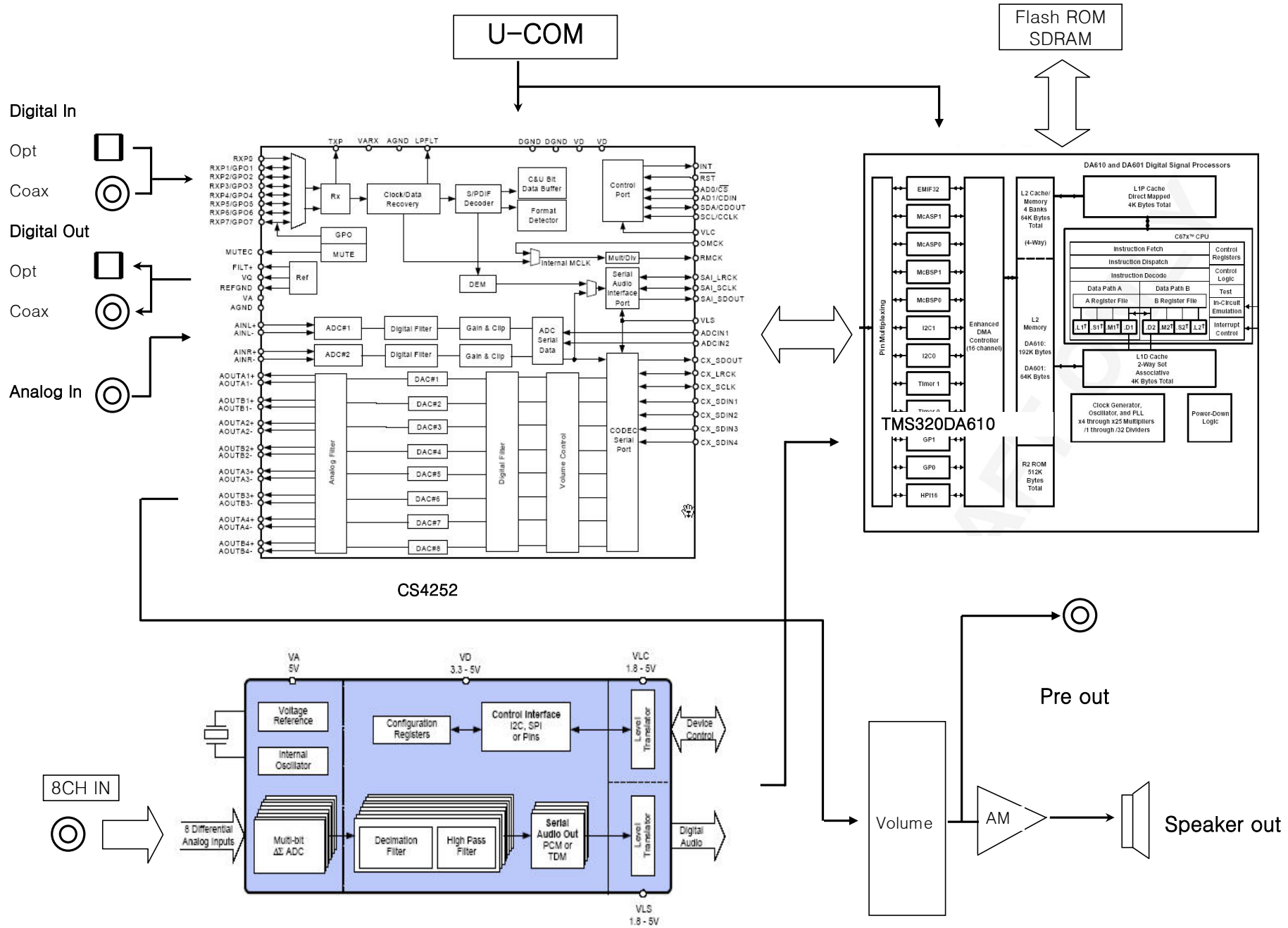

UPD70F3261YGC-8EA-A LQFP100 PORT DEFINE FOR AVR645_445

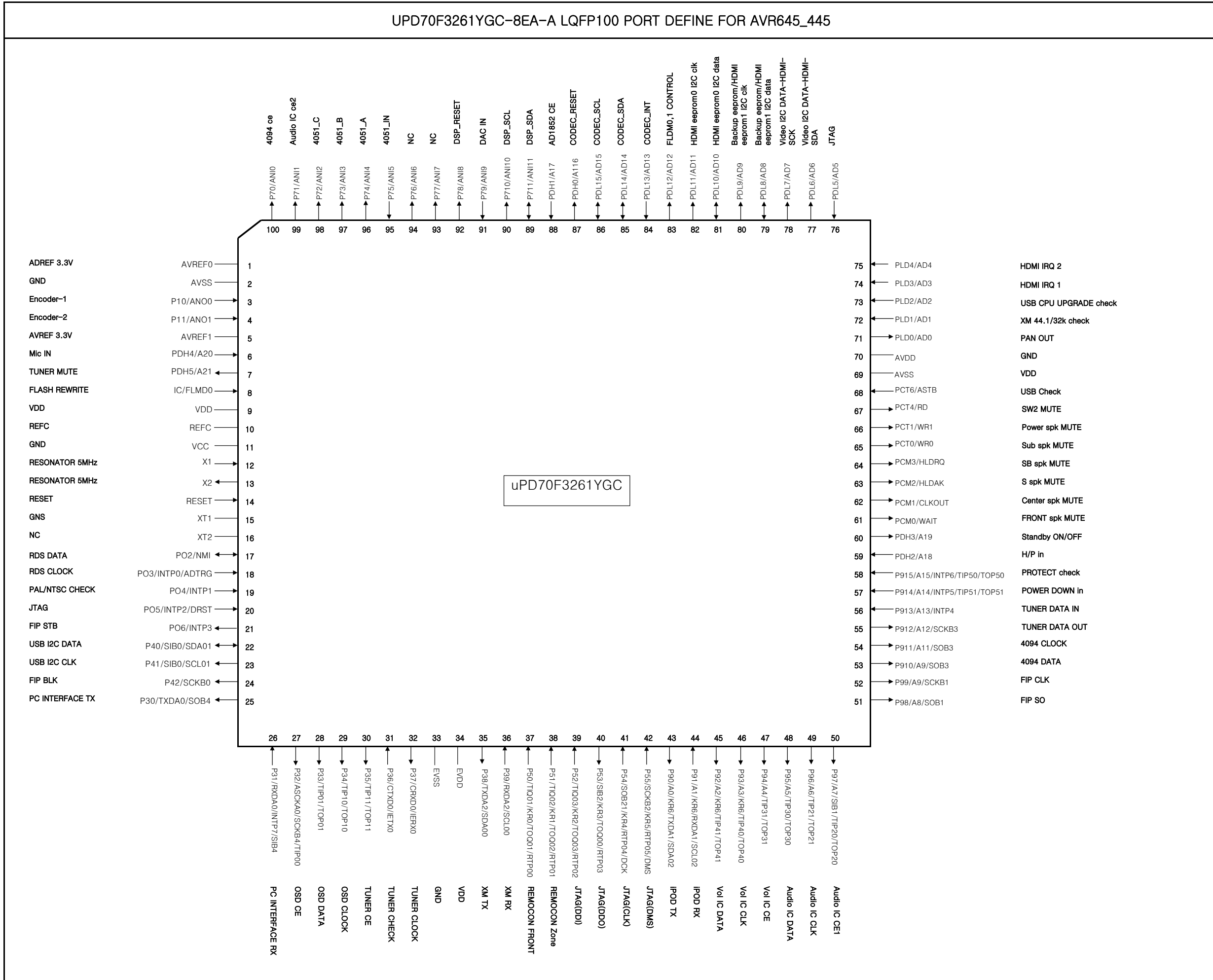

AVR645_445 MICOM PORT ASSIGN

PIN	PIN NAME	RECEIVER NAME	IN/OUT	FUNCTION
1	AV _{REF0}	3.3V	Supply	AD ref
2	AV _{SS}	GND	Supply	GND
3	P10/AN00	Encoder 1	IN	VOLUME ENCODER INPUT 1
4	P11/AN01	Encoder 2	IN	VOLUME ENCODER INPUT 2
5	AV _{REF1}	AVREF1	Supply	VDD
6	PDH4/A20	Mic in	IN	ROOM EQ mic in check
7	PDH5/A21	Tuner Mute	OUT	TUNER MUTE OUT
8	IC/FLMD0	Flash Rewrite	IC	Debug port
9	V _{DD}	VDD	Supply	VDD
10	REGC	REFC	Supply	VDD
11	V _{SS}	GND	Supply	GND
12	X1	RESONATOR 5MHz	IN	5.00MHz RESONATOR
13	X2	RESONATOR 5MHz	OUT	5.00MHz RESONATOR
14	/RESET	RESET	IN	LOW ACTIVE
15	XT1	GND	GND	clock port
16	XT2	NC	Open	NC
17	P02/NMI	RDS DATA(XM-IRQ)	IN/OUT	RDS_DATA (ext interrupt)
18	P03/INTP0/ADTRG	RDS Clock(XM-C/D)	IN	RDS_CLK (ext interrupt)
19	P04/INTP1	PAL/NTSC check	IN	ext interrupt
20	P05/INTP2/DRST	JTAG(DRST)	IN	Debug port
21	P06/INTP3	FIP STB	OUT	FIP DRIVER IC RESET / FL STROBE
22	P40/SIB0/SDA01	USB I2C DATA	IN/OUT	USB-SDA
23	P41/SOB0/SCL01	USB I2C CLK	OUT	USB-CLK
24	P42/SCKB0	FIP BLK	OUT	FIP DRIVER IC DATA IN / FL BLANK
25	P30/TXDA0/SOB4	PC INTERFACE TX	OUT	UART Interface
26	P31/RXDA0/INTP7/SIB4	PC INTERFACE RX	IN	UART Interface
27	P32/ASCKA0/SCKB4/TIP00	OSD CE	OUT	OSD CHIP ENABLE
28	P33/TIP01/TOP01	OSC DATA	OUT	OSD DATA
29	P34/TIP10/TOP10	OSC CLOCK	OUT	OSD CLK
30	P35/TIP11/TOP11	Tuner CE	OUT	TUNER PLL IC(LC72131) CHIP ENABLE
31	P36/CTXD0/IETX0	Tuned check	IN	TUNER PLL IC(LC72131) DATA IN / STEREO CHECK
32	P37/CRXD0/IERX0	Tuner CLOCK	OUT	TUNER PLL IC(LC72131) CLOCK
33	EV _{SS}	GND	Supply	GND
34	EV _{DD}	VDD	Supply	VDD
35	P38/TXDA2/SDA00	XM TX	OUT	UART Interface
36	P39/RXDA2/SCL00	XM RX	IN	UART Interface
37	P50/TIQ01/KR0/TOQ01/RTP00	Remocon Front	IN	Remocon Port
38	P51/TIQ02/KR1/TOQ02/RTP01	Remocon Zone	IN	Remocon Port
39	P52/TIQ03/KR2/TOQ03/RTP02	JTAG(DDI)	IN	Debug port
40	P53/SIB2/KR3/TOQ00/RTP03	JTAG(DDO)	OUT	Debug port
41	P54/SOB2/KR4/RTP04/DCK	JTAG(CLK)	IN	Debug port
42	P55/SCKB2/KR5/RTP05/DMS	JTAG(DMS)	IN	Debug port
43	P90/A0/KR6/TXDA1/SDA02	iPOD TX	OUT	UART Interface
44	P91/A1/RXDA1/SCL02	iPOD RX	IN	UART Interface
45	P92/A2/TIP41/TOP41	Vol IC DATA	OUT	TC9482/TC9459 DATA
46	P93/A3/TIP40/TOP40	Vol IC CLOCK	OUT	TC9482/TC9459 CLK
47	P94/A4/TIP31/TOP31	Vol IC CE	OUT	TC9482/TC9459 CE
48	P95/A5/TIP30/TOP30	Audio IC data	OUT	A DATA
49	P96/A6/TIP21/TOP21	Audio IC clk	OUT	A CLK
50	P97/A7/SIB1/TIP20/TOP20	Audio IC ce 1	OUT	TC9273/TC9162/TC9163 CE
51	P98/A8/SOB1	FIP SO	OUT	FIP DRIVER IC DATA OUT / FL DI
52	P99/A9/SCKB1	FIP CLK	OUT	FIP DRIVER IC CLOCK OUT / FL CLK
53	P910/A10/SIB3	4094 DATA	OUT	4094 DATA
54	P911/A11/SOB3	4094 CLOCK	OUT	4094 CLK
55	P912/A12/SCKB3	Tuner DATA out	OUT	72131 DIN
56	P913/A13/INTP4	Tuner DATA in	IN	72131 DOUT
57	P914/A14/INTP5/TIP51/TOP51	POWER DOWN check	IN	Ext Interrupt
58	P915/A15/INTP6/TIP50/TOP50	Protect check	IN	PROTECTION IN
59	PDH2/A18	H/P in	IN	HEADPHONE INPUT
60	PDH3/A19	Standby ON/OFF	OUT	MAIN POWER Relay control
61	PCM0/WAIT	Front spk Mute	OUT	FRONT SPEAKER MUTE
62	PCM1/CLKOUT	Gen spk Mute	OUT	CENTER SPEAKER MUTE
63	PCM2/HLDAK	S spk Mute	OUT	SURROUND SPEAKER MUTE
64	PCM3/HLDRQ	SB spk Mute	OUT	SURR BACK SPEAKER MUTE
65	PCT0/WR0	Sub spk Mute	OUT	SUB WOOFER MUTE
66	PCT1/WR1	Power Mute	OUT	POWER MUTE
67	PCT4/RD	SW2 MUTE	OUT	SUBWOOFER MUTE
68	PCT6/ASTB	USB CHECK	IN	USB CNT CHECK
69	BV _{SS}	VDD	Supply	VDD
70	BV _{DD}	GND	Supply	GND
71	PDL0/AD0	Fan Out	OUT	PWM control
72	PDL1/AD1	XM 44.1/32K CHECK	IN	XM-44.1/32K-CHECK
73	PDL2/AD2	USB CPU UPGRAD CHECK	IN	USB-UPGRADE
74	PDL3/AD3	HDMI IRQ 1	IN	HDMI IRQ 1
75	PDL4/AD4	HDMI IRQ 2	IN	HDMI IRQ 2

PIN	PIN NAME	RECEIVER NAME	IN/OUT	FUNCTION
76	PDL5/AD5/FLMD1	JTAG	IN	Debug port
77	PDL6/AD6	Video I2C DATA-HDMI-SDA	IN/OUT	HDMI i2c
78	PDL7/AD7	Video I2C CLK-HDMI-SCK	OUT	HDMI i2c
79	PDL8/AD8	backup eeprom/HDMI eeprom1 I2C data	IN/OUT	EEPROM DATA
80	PDL9/AD9	backup eeprom/HDMI eeprom1 I2C clk	OUT	EEPROM CLK
81	PDL10/AD10	HDMI eeprom0 I2C data	IN/OUT	EEPROM DATA
82	PDL11/AD11	HDMI eeprom0 I2C clk	OUT	EEPROM CLK
83	PDL12/AD12	FLDM0,1 CONTROL	OUT	Flash programming mode
84	PDL13/AD13	CODEC_INT	IN	CS42528
85	PDL14/AD14	CODEC_SDA	IN/OUT	CS42528
86	PDL15/AD15	CODEC_SCL	IN/OUT	CS42528
87	PDH0/A16	CODEC_RESET	OUT	CS42528
88	PDH1/A17	DAC CE	IN	DAC CE
89	P711/ANI11	DSP_SDA	IN/OUT	DSP I2C DATA
90	P710/ANI10	DSP_SCL	OUT	DSP I2C CLOCK
91	P79/ANI9	DAC IN	IN	CS4391A M1
92	P78/ANI8	DSP_RESET	OUT	DA610 RESET
93	P77/ANI7	NC	OUT	NC
94	P76/ANI6	NC	OUT	NC
95	P75/ANI5	4051_IN	IN	4051_IN
96	P74/ANI4	4051_A	OUT	4051_A
97	P73/ANI3	4051_B	OUT	4051_B
98	P72/ANI2	4051_C	OUT	4051_C
99	P71/ANI1	Audio ic ce2	OUT	TC9162_CE
100	P70/ANI0	4094 ce	OUT	4094 CHIP ENABLE

Semiconductor pinout drawings

•IC

1. 24LC256 (DSP: IC12)

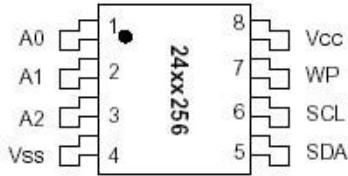

PIN FUNCTION TABLE

Name	Function
A0, A1, A2	User Configurable Chip Selects
Vss	Ground
SDA	Serial Data
SCL	Serial Clock
WP	Write Protect Input
Vcc	+1.8 to 5.5V (24AA256) +2.5 to 5.5V (24LC256)

BLOCK DIAGRAM

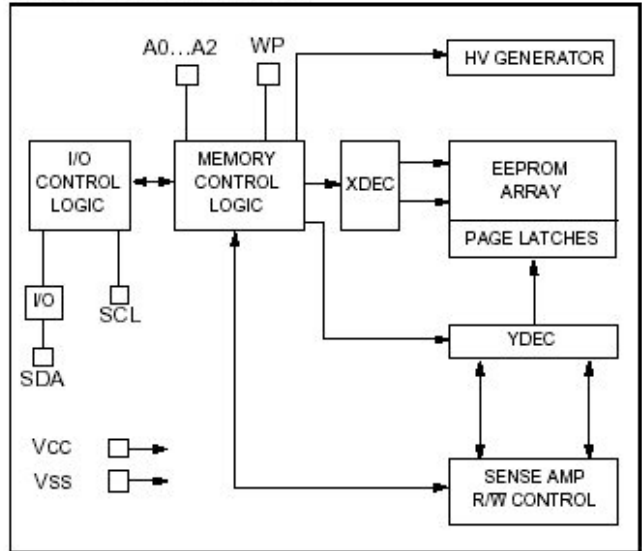

2. 24LC64-I/SNG (DSP: IC38)

Block Diagram

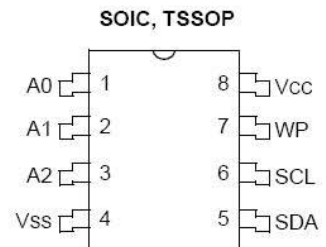
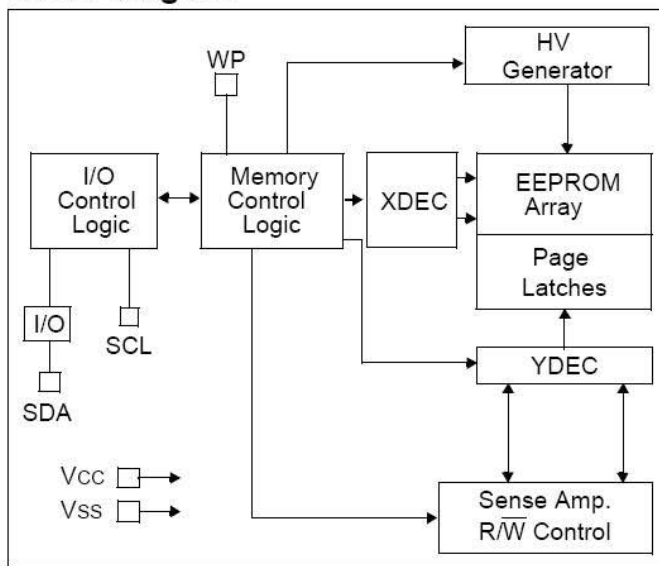

PIN FUNCTION TABLE

Name	Function
A0,A1,A2	User Configurable Chip Selects
Vss	Ground
SDA	Serial Data
SCL	Serial Clock
WP	Write Protect Input
Vcc	+1.8 to 5.5V (24AA64) +2.5 to 5.5V (24LC64)

3. 24LC08BT (VIDEO: IC43 IC46)

BLOCK DIAGRAM

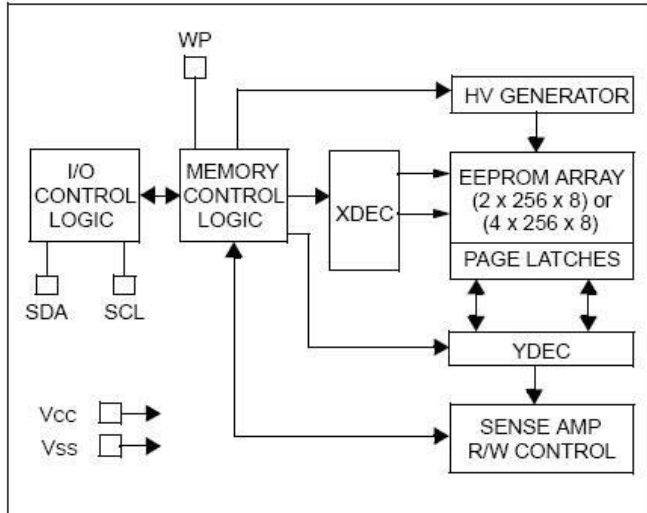

PDIP, SOIC

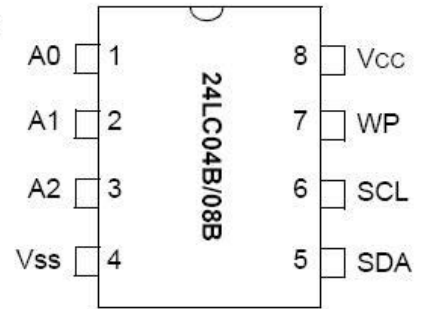

4. BU4094BCF SOP16 (DSP: IC14 IC15 IC17)
 (SUPPLY: IC406)
 (VIDEO: IC18 IC19 IC20 IC21 IC22)

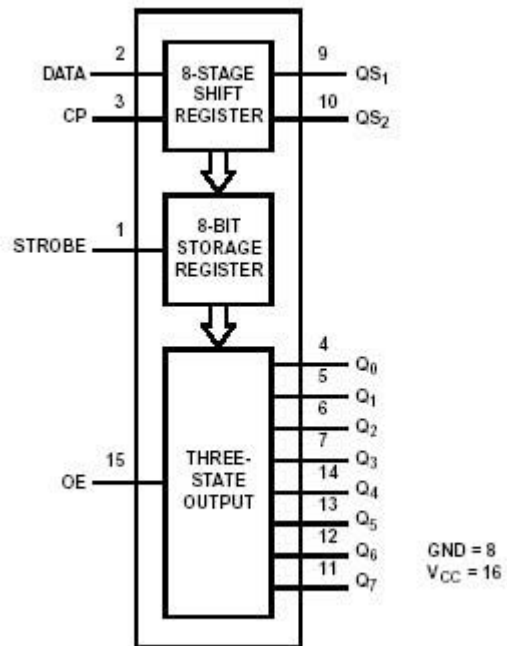
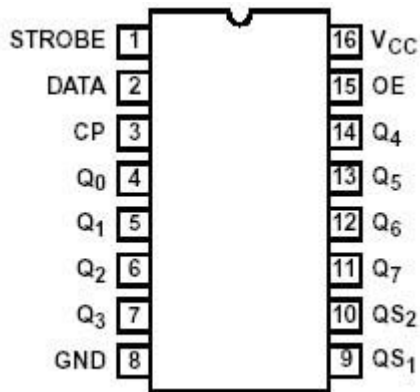

GND = 8
 Vcc = 16

5. BU4051BCF SOP16 (DSP: IC1)

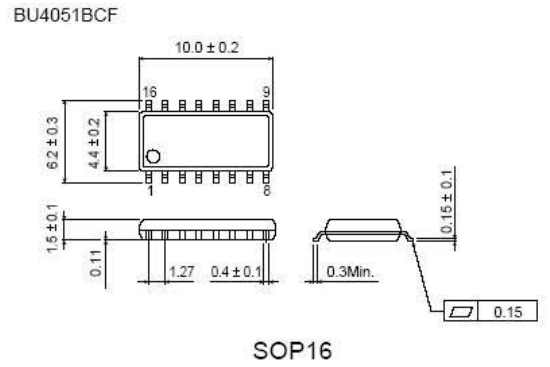
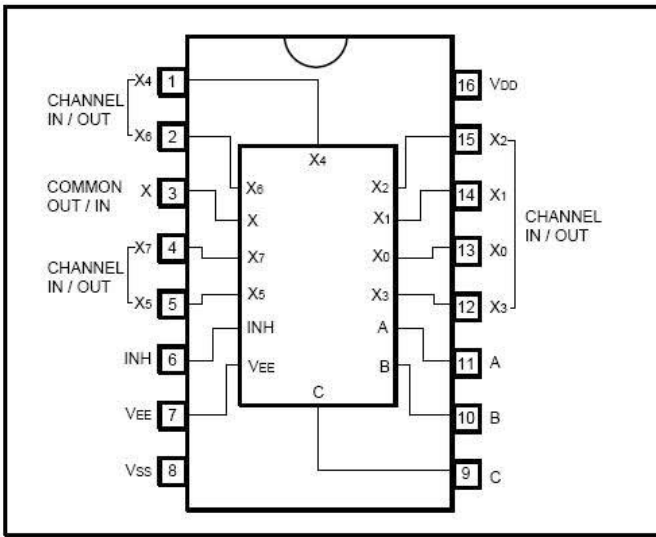

6. BU4052BCF SOP16 (SUPPLY: IC34)

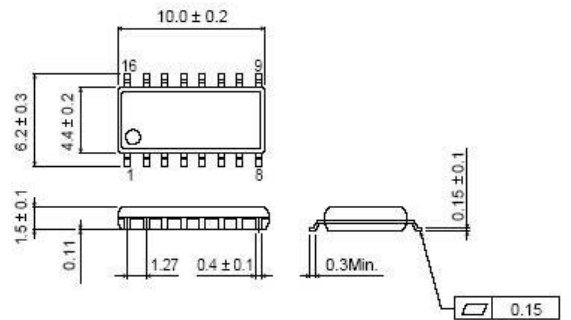
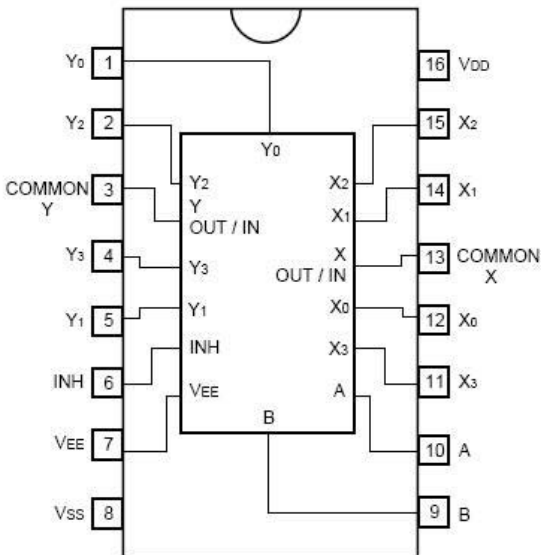

7. 74HCU04M (DSP: IC34 IC35)

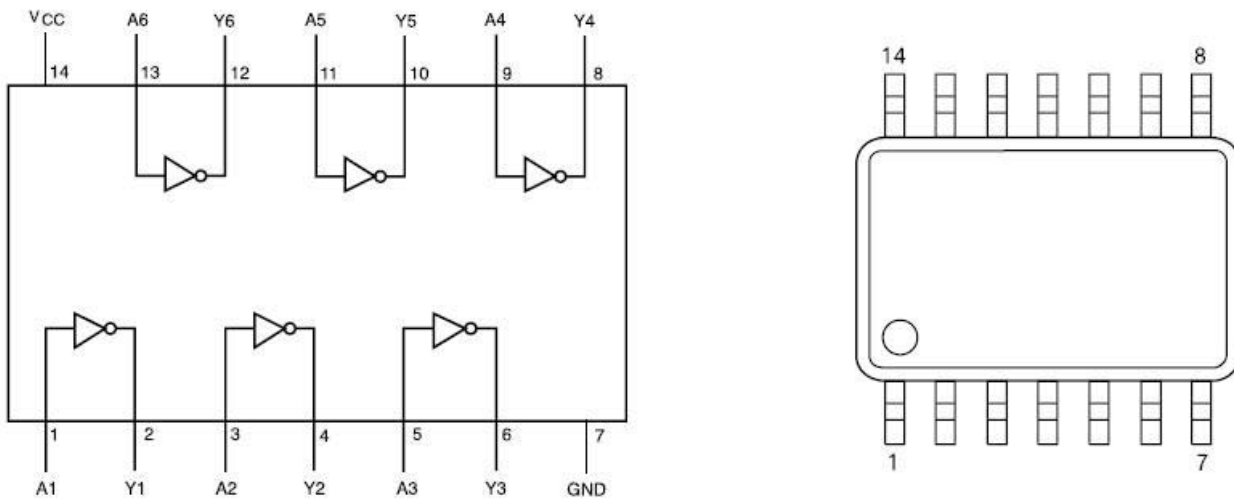

8. SN74ALVC244PWR (VIDEO: IC50 IC51 IC53)

LOGIC DIAGRAM (POSITIVE LOGIC)

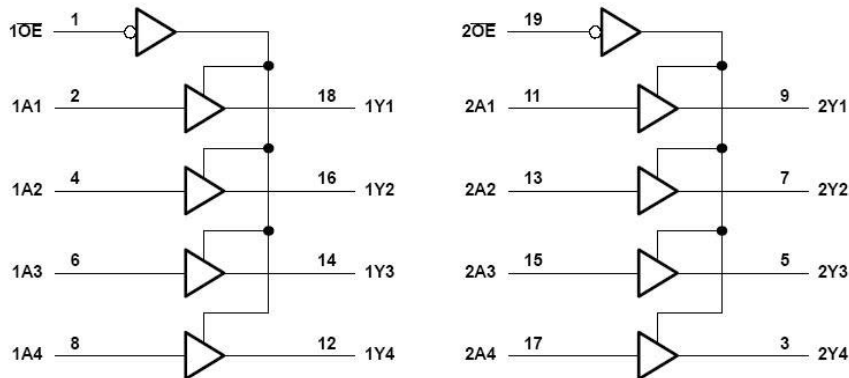

DIM	PINS **					
	8	14	16	20	24	28
A MAX	3,10	5,10	5,10	6,60	7,90	9,80
A MIN	2,90	4,90	4,90	6,40	7,70	9,60

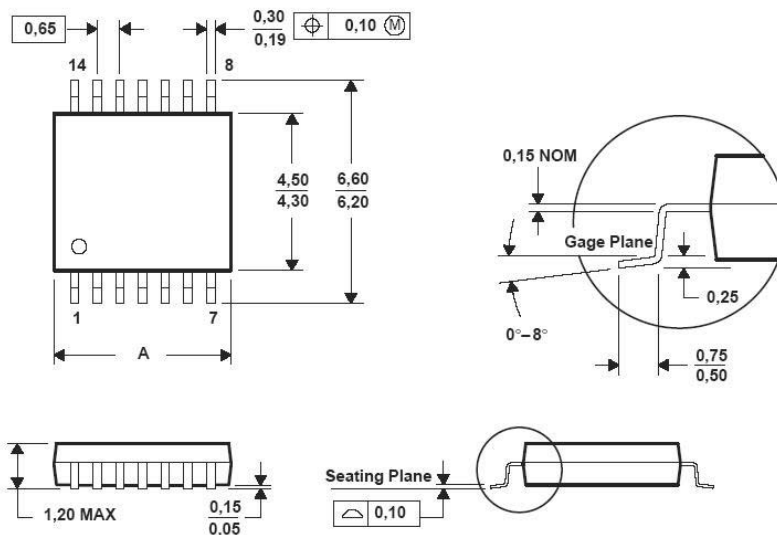

9. XMDIC QFP48 (DSP: IC32)

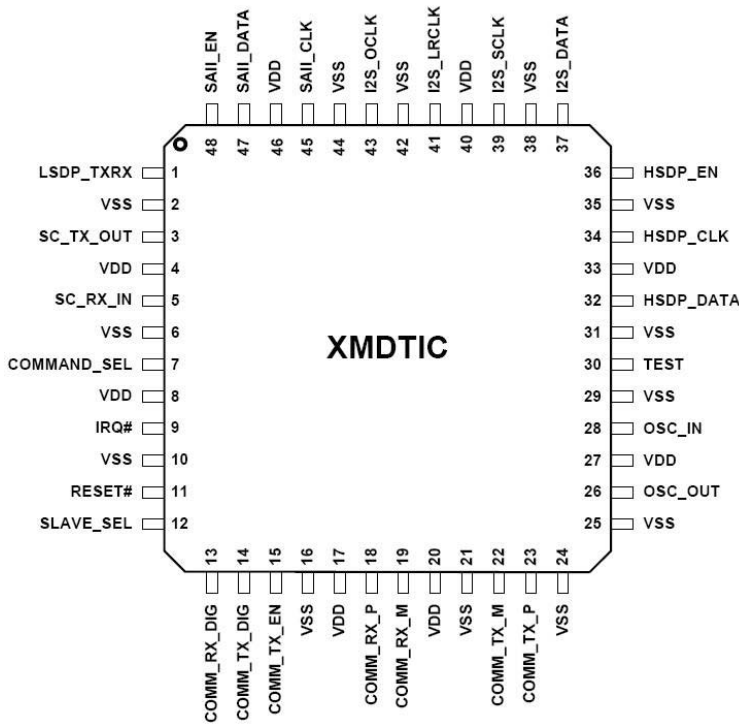
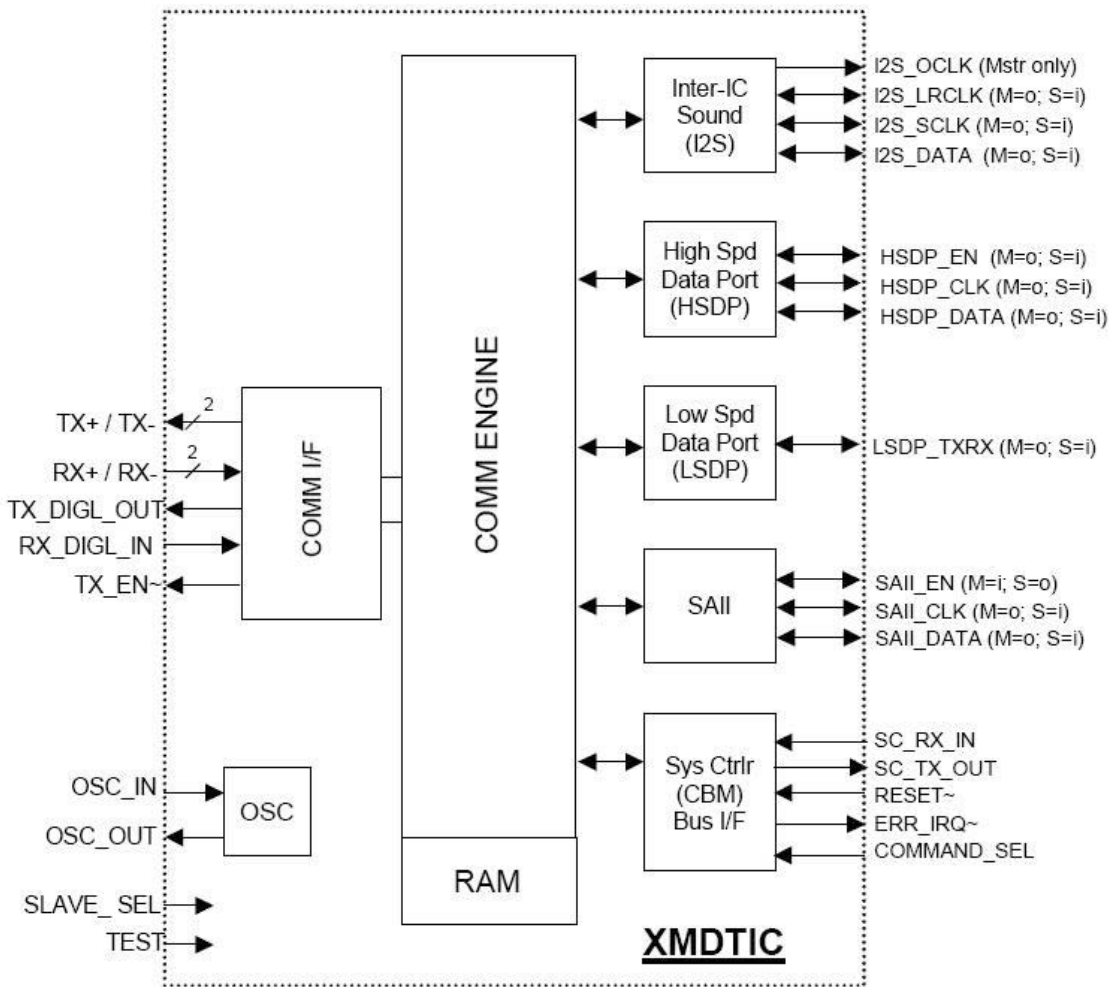

10. TMS320DA610-250 PQFP208 (DSP:IC21)

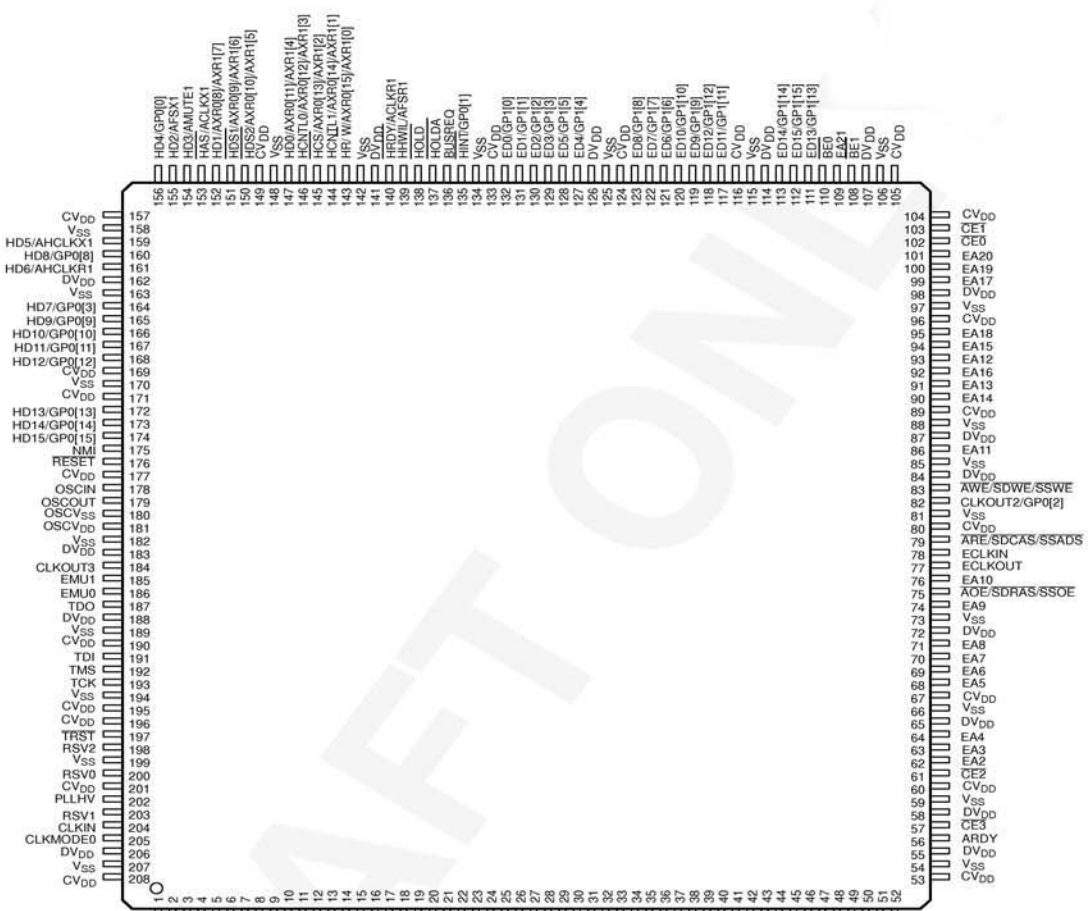

functional block and CPU (DSP core) diagram

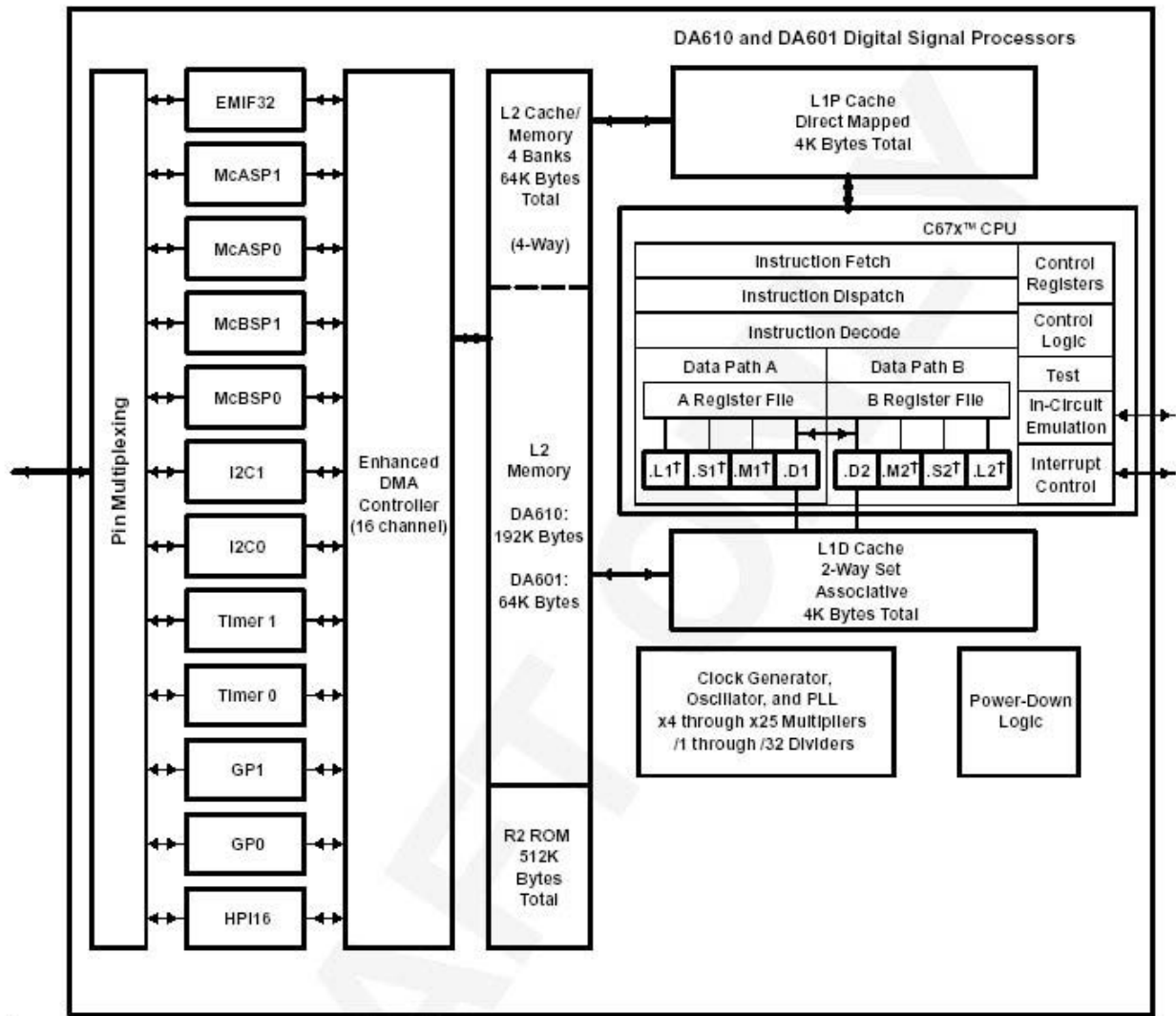

11. SN74LVC1G125DCKT (DSP: IC8, 36, 37)

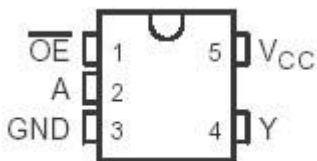

logic symbol†

FUNCTION TABLE

INPUTS		OUTPUT
OE	A	Y
L	H	H
L	L	L
H	X	Z



logic diagram (positive logic)

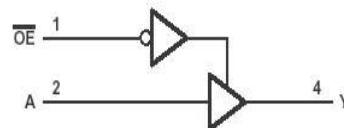

12. 74VHC244M (DSP:IC16)



PIN CONNECTION AND IEC LOGIC SYMBOLS

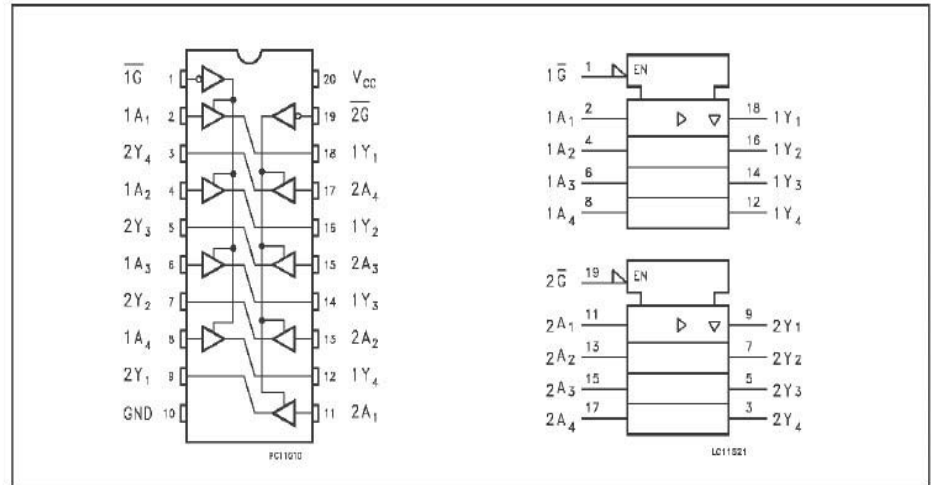

13. AT49BV163DT (DSP:IC22)

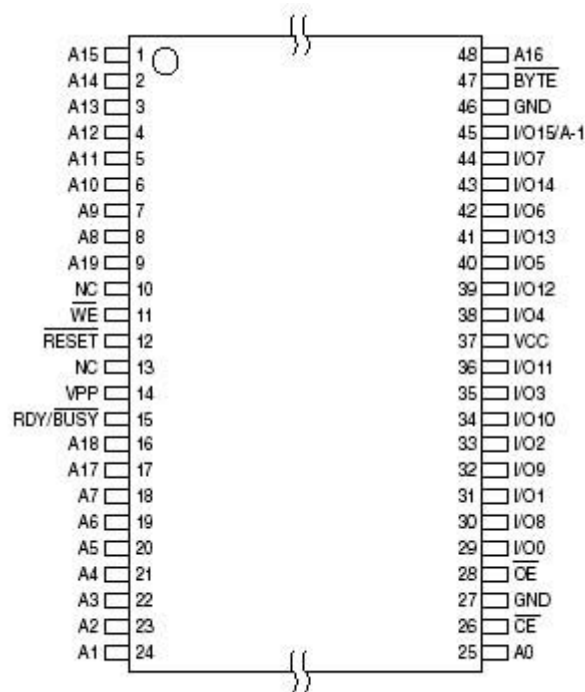

Block Diagram

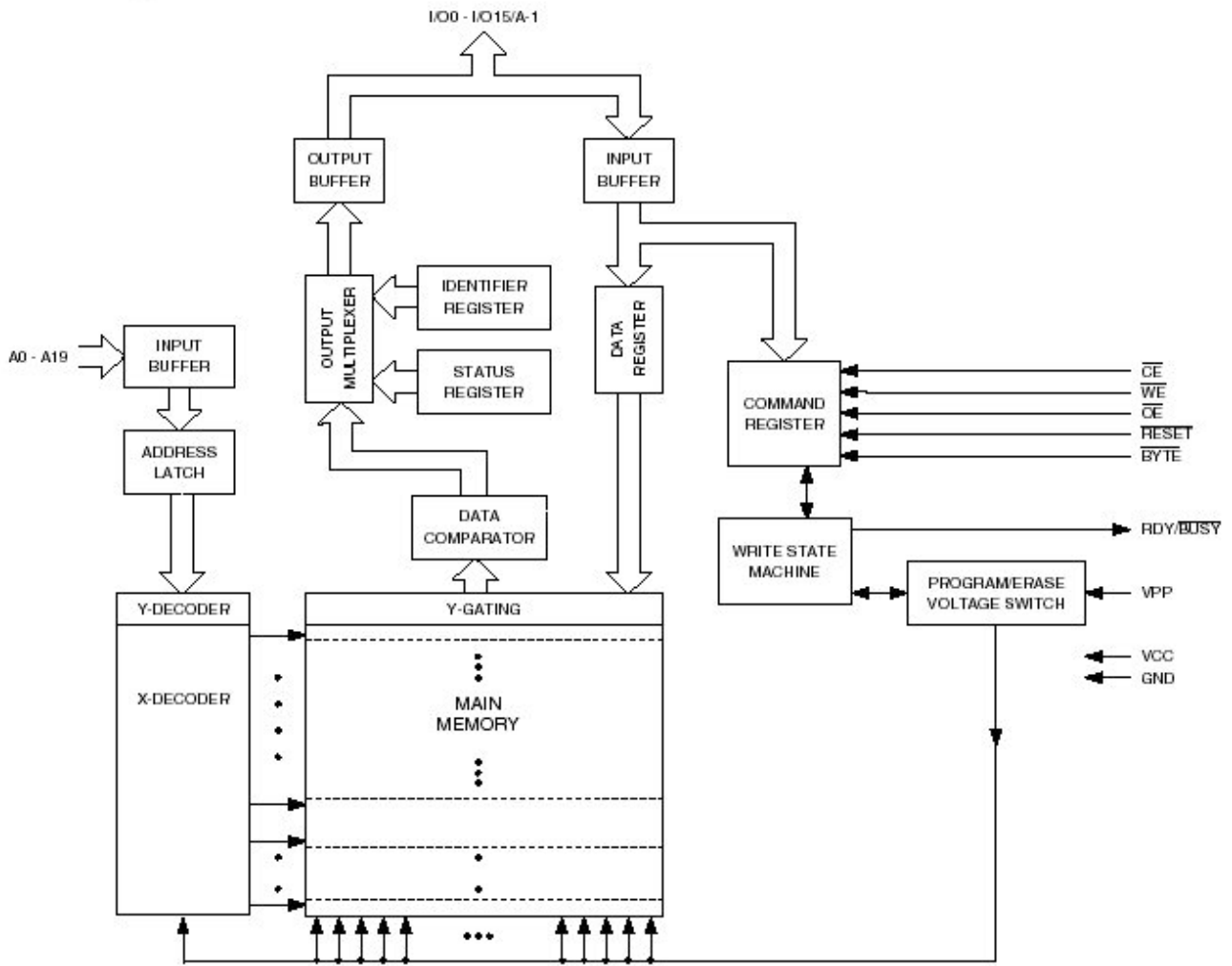

14. 74AHC1G (DSP: IC7)

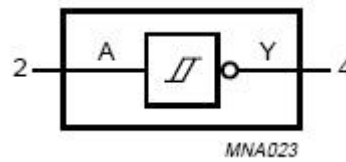
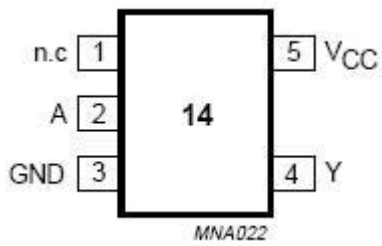

15. DS1233AZ (DSP: IC4)

BLOCK DIAGRAM Figure 1

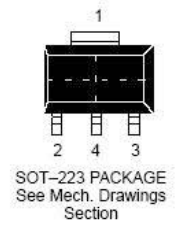
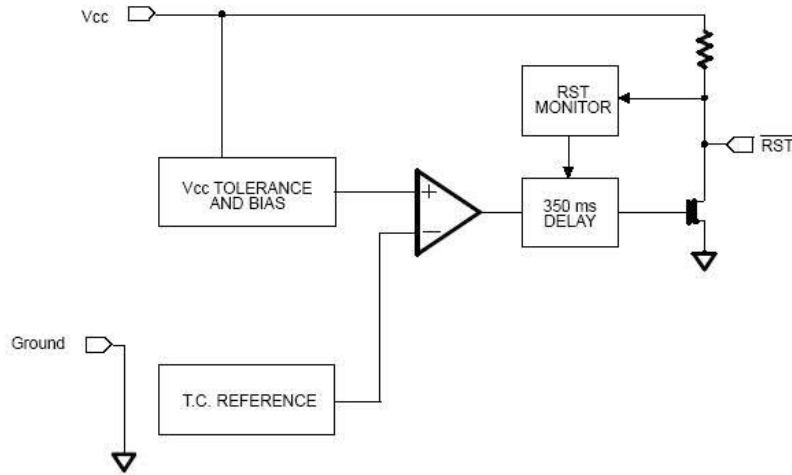

PIN DESCRIPTION

- PIN 1 GROUND
- PIN 2 RESET
- PIN 3 V_{CC}
- PIN 4 GROUND (SOT-223 ONLY)

16. BU4053BCF (VIDEO: IC12 IC42 IC45)

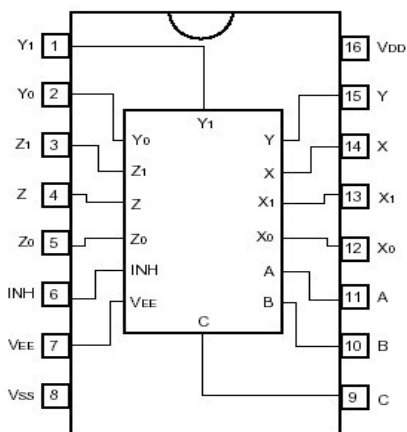

● Logic circuit diagram

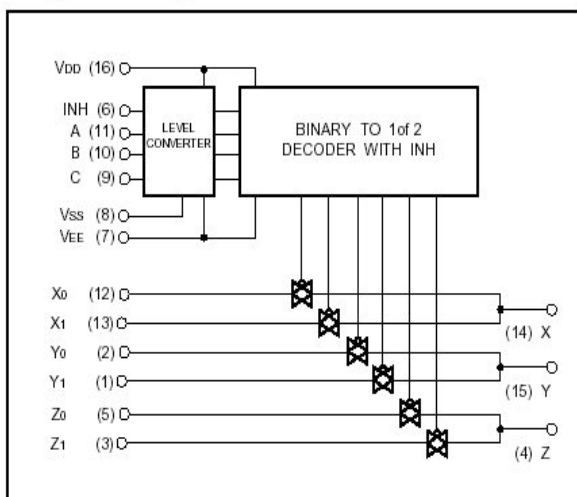

● Truth table

INH	A	B	C	ON SWITCH
L	L	L	L	X ₀ Y ₀ Z ₀
L	H	L	L	X ₁ Y ₀ Z ₀
L	L	H	L	X ₀ Y ₁ Z ₀
L	H	H	L	X ₁ Y ₁ Z ₀
L	L	L	H	X ₀ Y ₀ Z ₁
L	H	L	H	X ₁ Y ₀ Z ₁
L	L	H	H	X ₀ Y ₁ Z ₁
L	H	H	H	X ₁ Y ₁ Z ₁
H	X	X	X	NONE

X: Irrelevant

17. TUSB3200A (DSP: IC33)

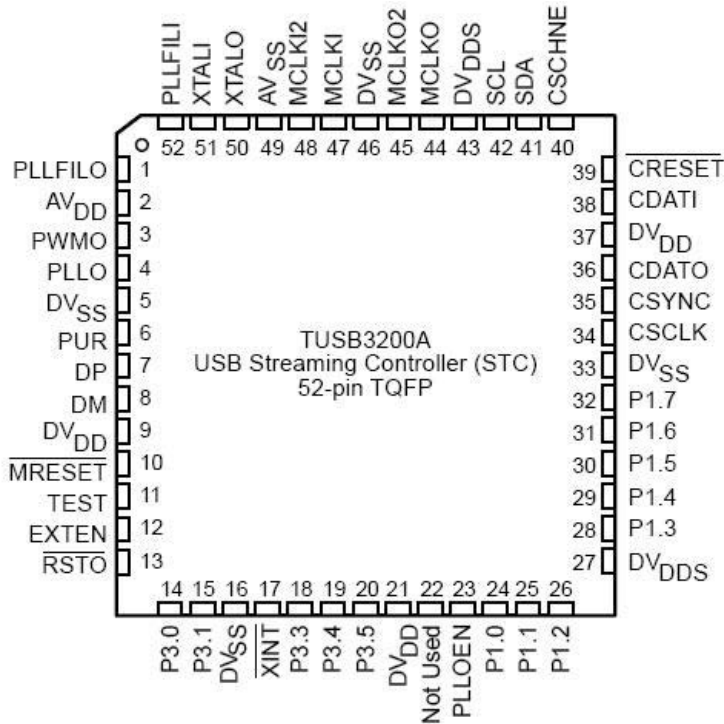
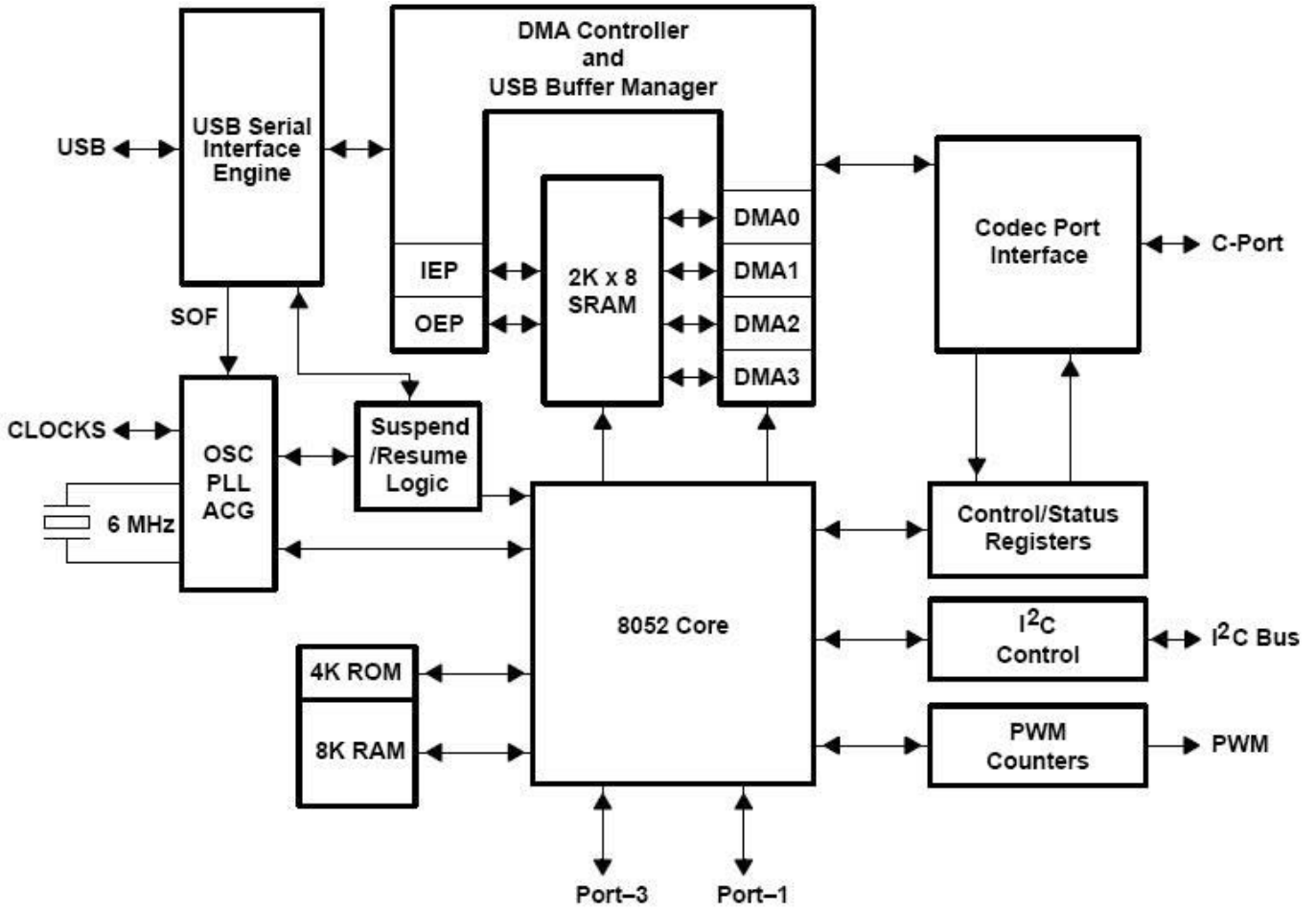

18. K4S161622H-UC60 (DSP:IC23)

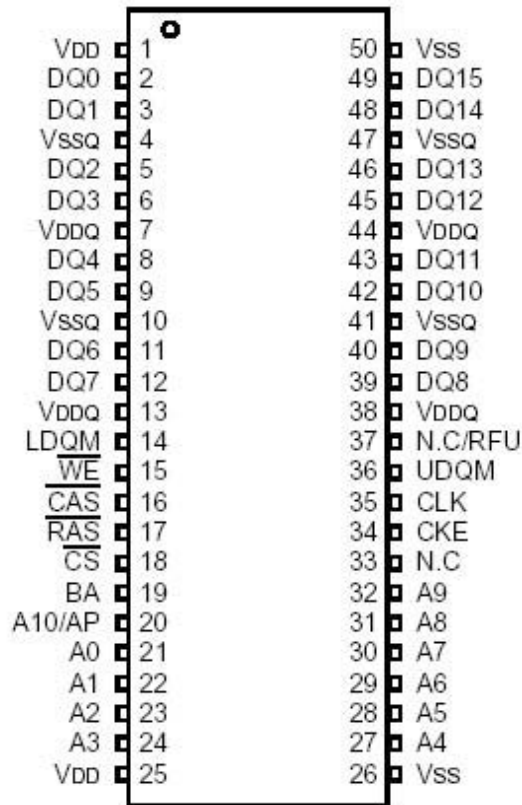

FUNCTIONAL BLOCK DIAGRAM

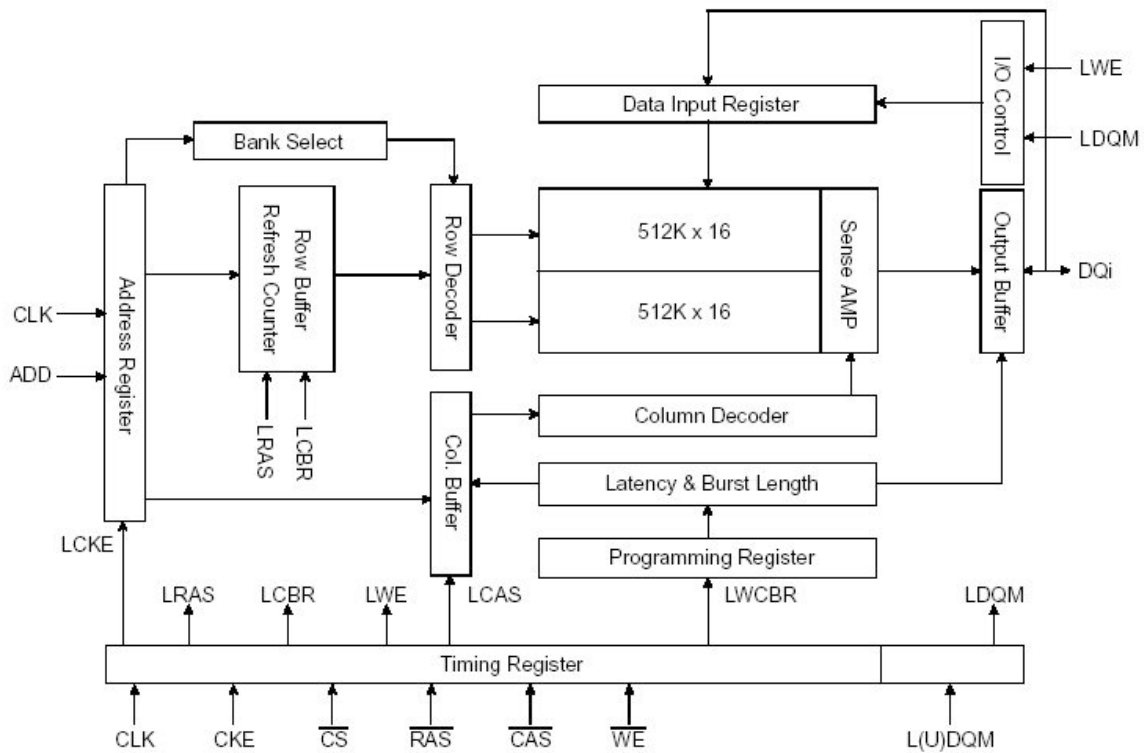

PIN FUNCTION DESCRIPTION

Pin	Name	Input Function
CLK	<i>System Clock</i>	Active on the positive going edge to sample all inputs.
$\overline{\text{CS}}$	<i>Chip Select</i>	Disables or enables device operation by masking or enabling all inputs except CLK, CKE and L(U)DQM
CKE	<i>Clock Enable</i>	Masks system clock to freeze operation from the next clock cycle. CKE should be enabled at least one cycle prior to new command. Disable input buffers for power down in standby.
A0 ~ A10/AP	<i>Address</i>	Row / column addresses are multiplexed on the same pins. Row address : RA0 ~ RA10, column address : CA0 ~ CA7
BA	<i>Bank Select Address</i>	Selects bank to be activated during row address latch time. Selects bank for read/write during column address latch time.
$\overline{\text{RAS}}$	<i>Row Address Strobe</i>	Latches row addresses on the positive going edge of the CLK with $\overline{\text{RAS}}$ low. Enables row access & precharge.
$\overline{\text{CAS}}$	<i>Column Address Strobe</i>	Latches column addresses on the positive going edge of the CLK with $\overline{\text{CAS}}$ low. Enables column access.
$\overline{\text{WE}}$	<i>Write Enable</i>	Enables write operation and row precharge. Latches data in starting from CAS, $\overline{\text{WE}}$ active.
L(U)DQM	<i>Data Input/Output Mask</i>	Makes data output Hi-Z, tSHZ after the clock and masks the output. Blocks data input when L(U)DQM active.
DQ0 ~ 15	<i>Data Input/Output</i>	Data inputs/outputs are multiplexed on the same pins.
VDD/VSS	<i>Power Supply/Ground</i>	Power and ground for the input buffers and the core logic.
VDDQ/VSSQ	<i>Data Output Power/Ground</i>	Isolated power supply and ground for the output buffers to provide improved noise immunity.
N.C/RFU	<i>No Connection/ Reserved for Future Use</i>	This pin is recommended to be left No Connection on the device.

19. KIC9162CFG (DSP: IC56 PROCESSOR: IC15)
 KIC9163CFG (PROCESSOR: IC12)

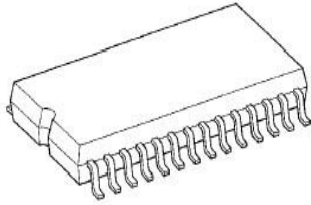

V _{SS}	1	28	V _{DD}
L-S ₁	2	27	R-S ₁
L-S ₂	3	26	R-S ₂
L-COM ₁	4	25	R-COM ₁
L-S ₃	5	24	R-S ₃
L-S ₄	6	23	R-S ₄
L-COM ₂	7	22	R-COM ₂
L-S ₅	8	21	R-S ₅
L-S ₆	9	20	R-S ₆
L-COM ₃	10	19	R-COM ₃
L-S ₇	11	18	R-S ₇
L-COM ₄	12	17	R-COM ₄
ST	13	16	DATA
GND	14	15	CK

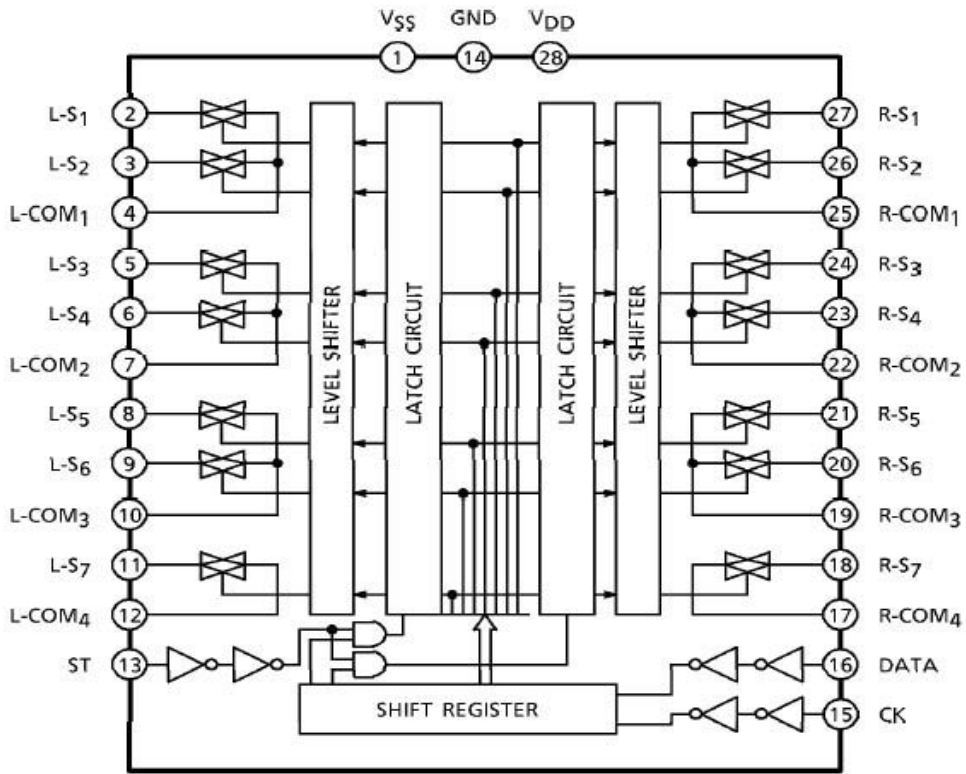

20. LC74763M (VIDEO:IC27)

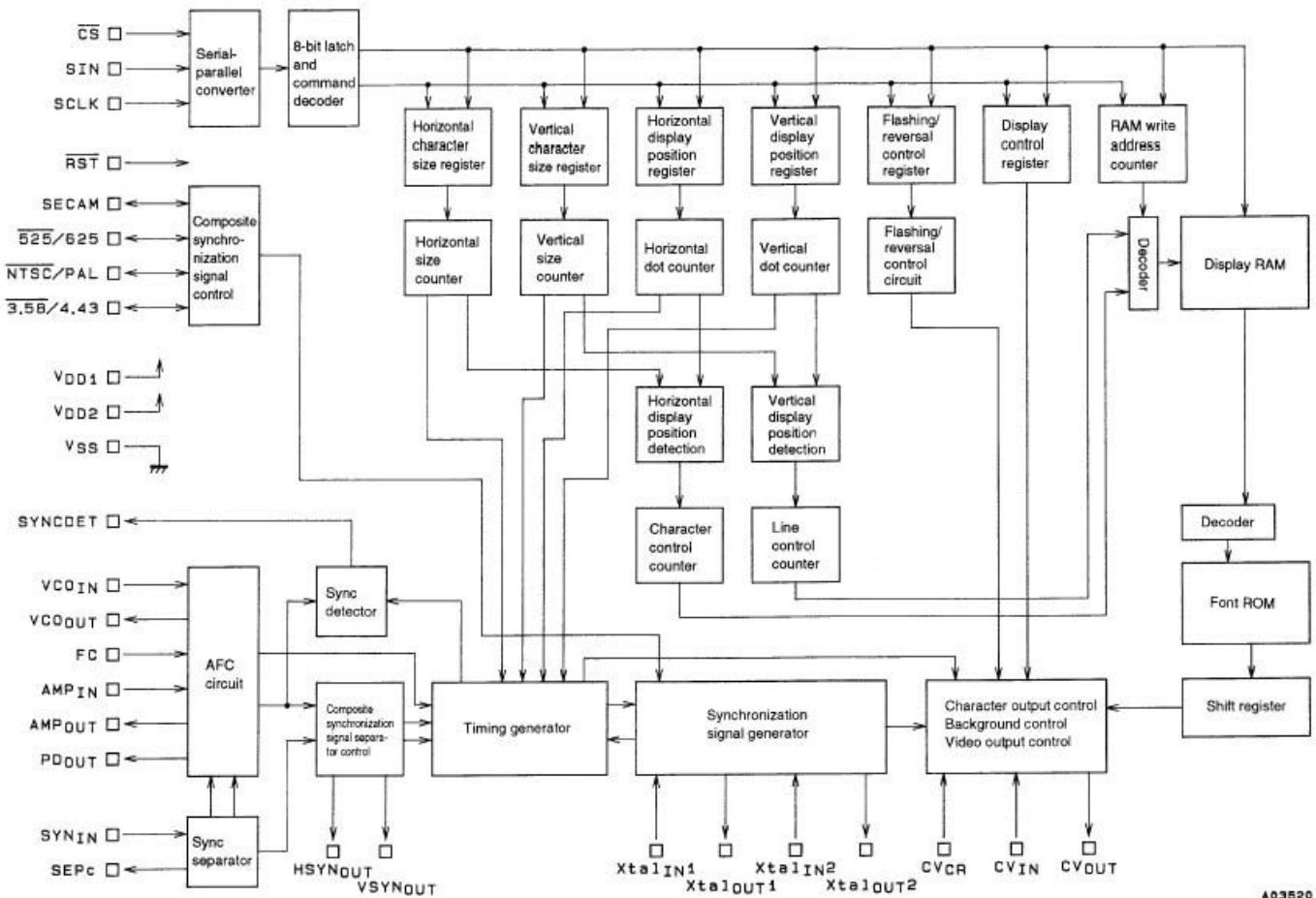
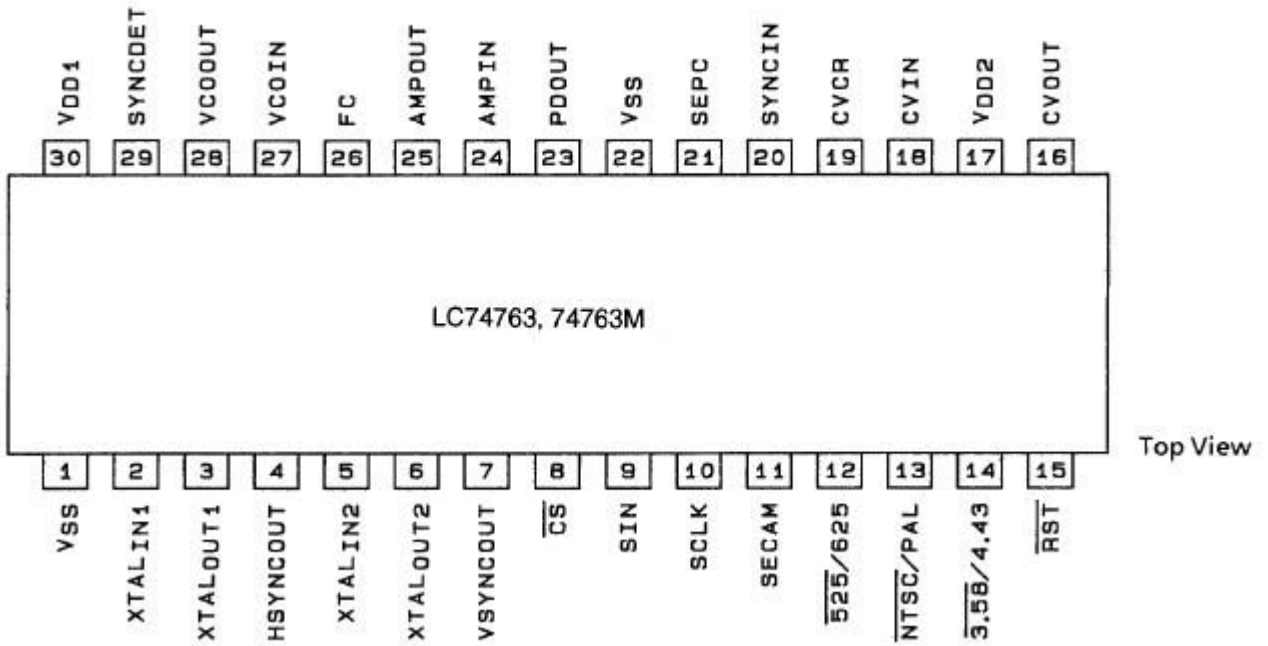

A03520

21. NJM2068M (DSP: IC61, 62, 63, 64, 65, 66, 67, 68, 69, 71, 72, 73, 74, 75, 76, 77, 78, 80)
 (FRONT: IC50, MAIN: IC22)
 (PROCESSOR: IC2, 3, 4, 5, 6, 7, 10, 11, 25, 13, 14, 18, 19, 21, 22, 23, 24, 26)
 (VIDEO: IC60)

NJM4580M (PROCESSOR: IC1)

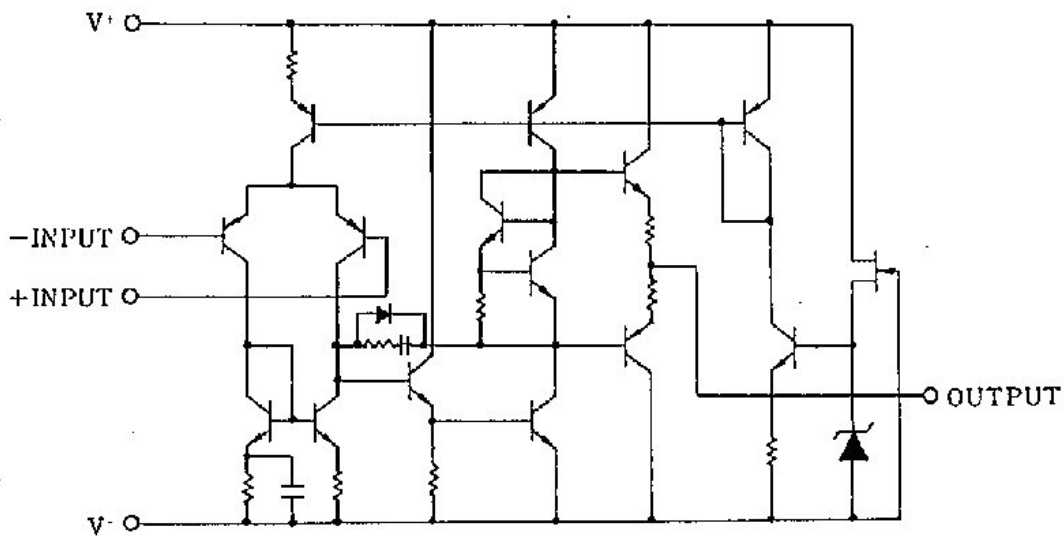

22. TC9482BFG (PROCESSOR:IC16, 17)

TC9482F

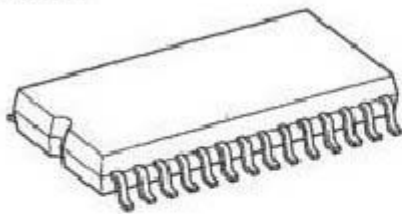

SOP28-P-450-1.27

V _{SS}	1	28	V _{DD}
NC	2	27	TEST
L-OUTA	3	26	R-OUTA
L-INA	4	25	R-INA
L-A-GNDA	5	24	R-A-GNDA
L-OUTB	6	23	R-OUTB
L-INB	7	22	R-INB
L-A-GNDB	8	21	R-A-GNDB
L-OUTC	9	20	R-OUTC
L-INC	10	19	R-INC
L-A-GNDC	11	18	R-A-GNDC
CS1	12	17	CS2
GND	13	16	STB
CK	14	15	DATA

23. NJM317DL1 (DSP: IC25)

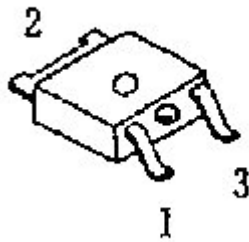

1. Adjustment
2. Output
3. Input

24. MAX3223CDWR (SUPPLY: IC31)

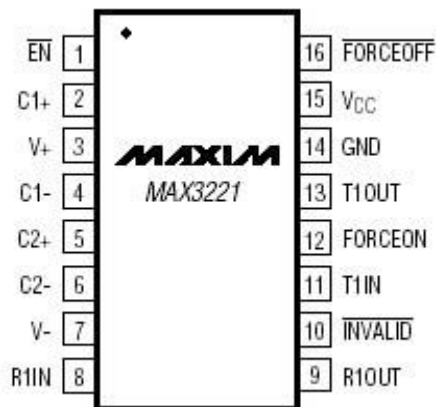

PIN			NAME	FUNCTION
MAX3221	MAX3223	MAX3243		
1	1	—	$\overline{\text{EN}}$	Receiver Enable Control. Drive low for normal operation. Drive high to force the receiver outputs into a high-Z state.
5	5	1	C2+	Positive terminal of inverting charge-pump capacitor
6	6	2	C2-	Negative terminal of inverting charge-pump capacitor
7	7	3	V-	-5.5V generated by the charge pump
8	9, 16	4-8	R_IN	RS-232 Receiver Inputs
13	8, 17	9, 10, 11	T_OUT	RS-232 Transmitter Outputs
11	12, 13	12, 13, 14	T_IN	TTL/CMOS Transmitter Inputs
9	10, 15	15-19	R_OUT	TTL/CMOS Receiver Outputs
—	—	20	R2OUTB	Noninverting Receiver Output—active in shutdown
10	11	21	$\overline{\text{INVALID}}$	Output of the valid signal detector. Indicates if a valid RS-232 level is present on receiver inputs logic "1".
16	20	22	FORCEOFF	Drive low to shut down transmitters and on-board power supply. This overrides all automatic circuitry and FORCEON (Table 1).
12	14	23	FORCEON	Drive high to override automatic circuitry keeping transmitters on (FORCEOFF must be high) (Table 1).
4	4	24	C1-	Negative terminal of the voltage doubler charge-pump capacitor
14	18	25	GND	Ground
15	19	26	VCC	+3.0V to +5.5V Supply Voltage
3	3	27	V+	+5.5V generated by the charge pump
2	2	28	C1+	Positive terminal of the voltage doubler charge-pump capacitor

25. MM1511XNRE (VIDEO: IC32)

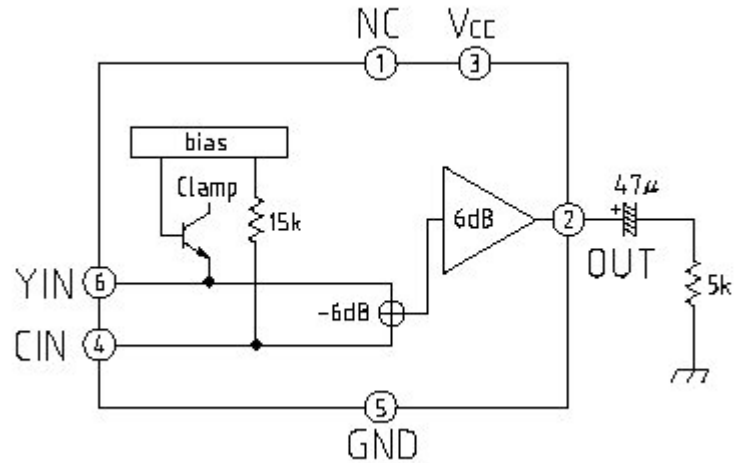

26. MM1503XNRE (VIDEO: IC25 IC26 IC33 IC34 IC35 IC36 IC37)

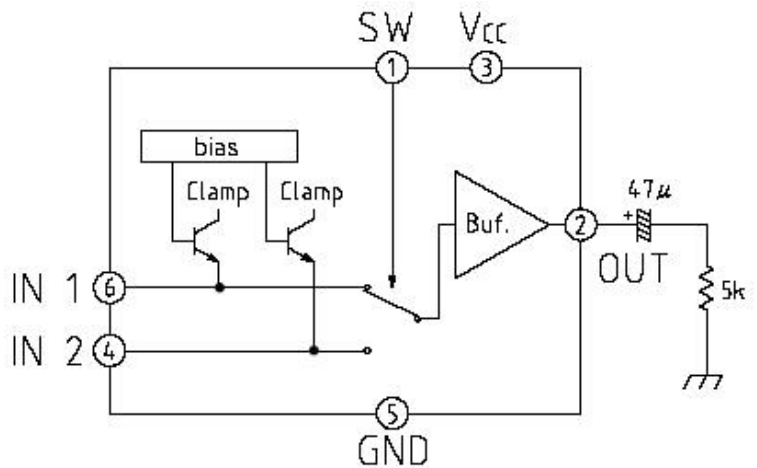

27. NJM2872AF33 (DSP: 6)

■ PIN CONFIGURATION

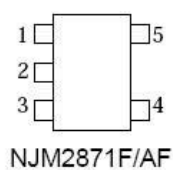

PIN FUNCTION
 1. CONTROL (Active High)
 2. GND
 3. NOISE BYPASS
 4. V_{OUT}
 5. V_{IN}

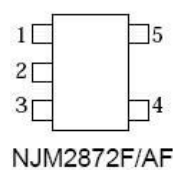

PIN FUNCTION
 1. V_{IN}
 2. GND
 3. CONTROL (Active High)
 4. NOISE BYPASS
 5. V_{OUT}

■ EQUIVALENT CIRCUIT

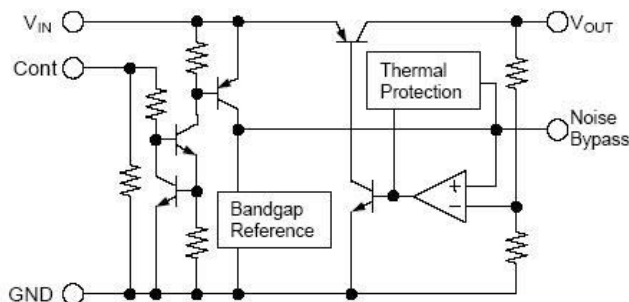

28. NJM2296M (VIDEO:IC13, 14, 15)

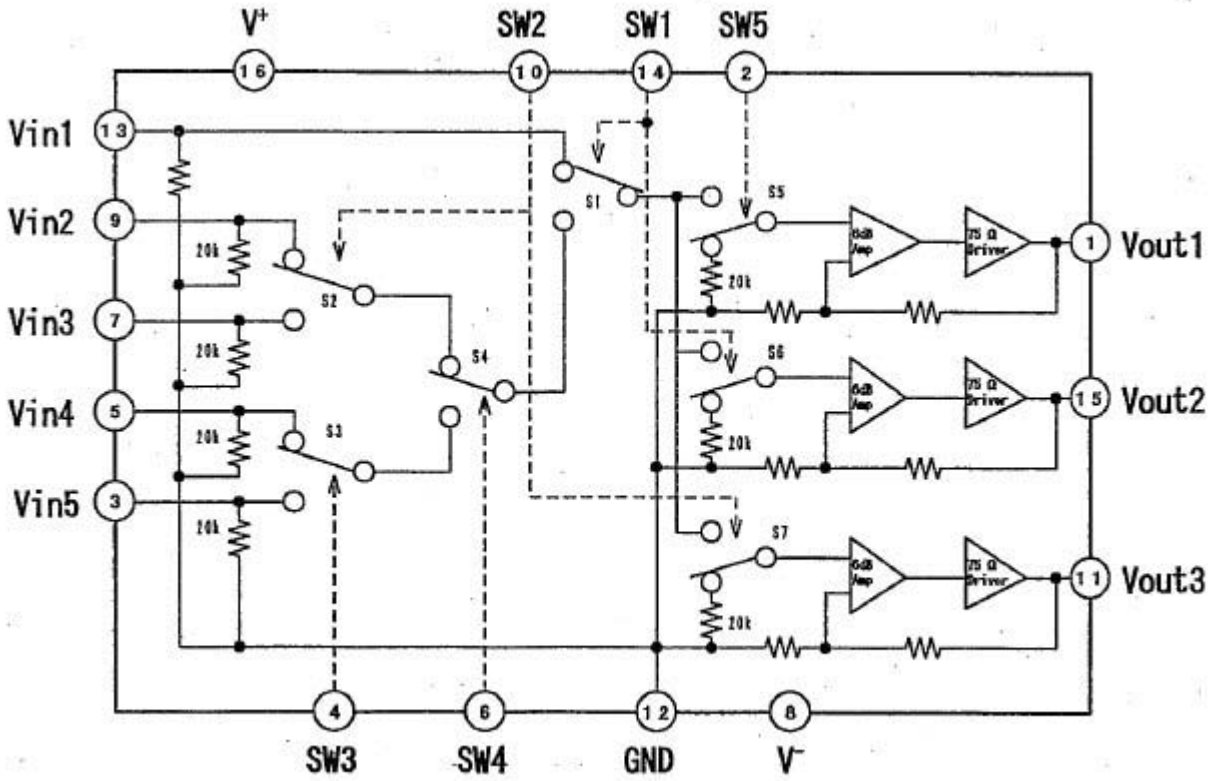
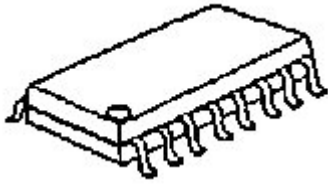

29. NJM2586M (VIDEO:IC38)

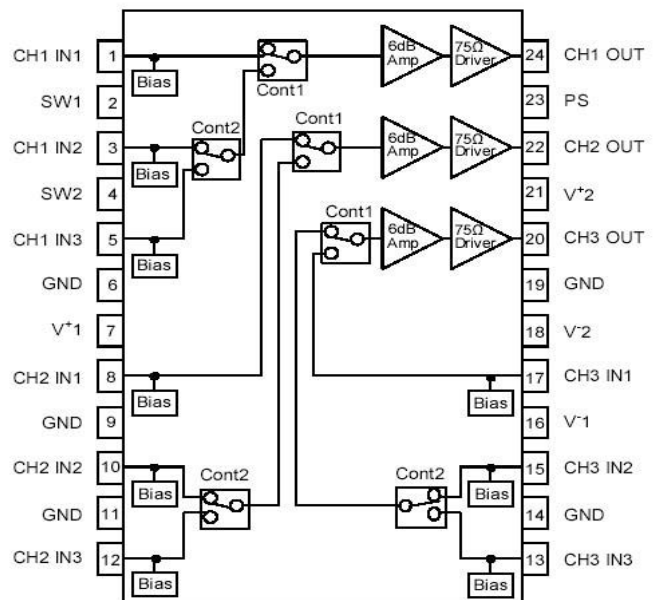
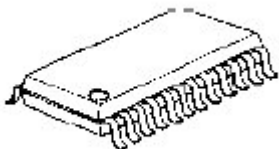

30. NJM4556AD (PROCESSOR:IC20)

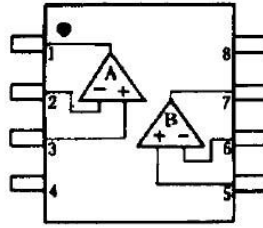
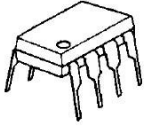

PIN FUNCTION

- 1.A OUTPUT
- 2.A -INPUT
- 3.A +INPUT
- 4.V⁻
- 5.B +INPUT
- 6.B -INPUT
- 7.B OUTPUT
- 8.V⁺

31. PC-17T1 (DSP: PC11 SUPPLY: IC32, 33)

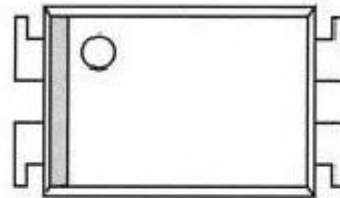
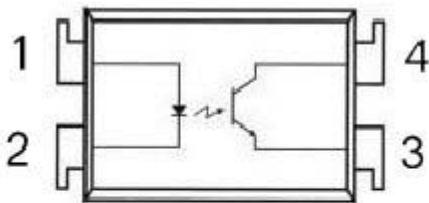

PIN Connections

- 1.Anode
- 2.C athode
- 3.E mitter
- 4.C ollector

32. TC9273CFG-004 (PROCESSOR: IC8, 9)

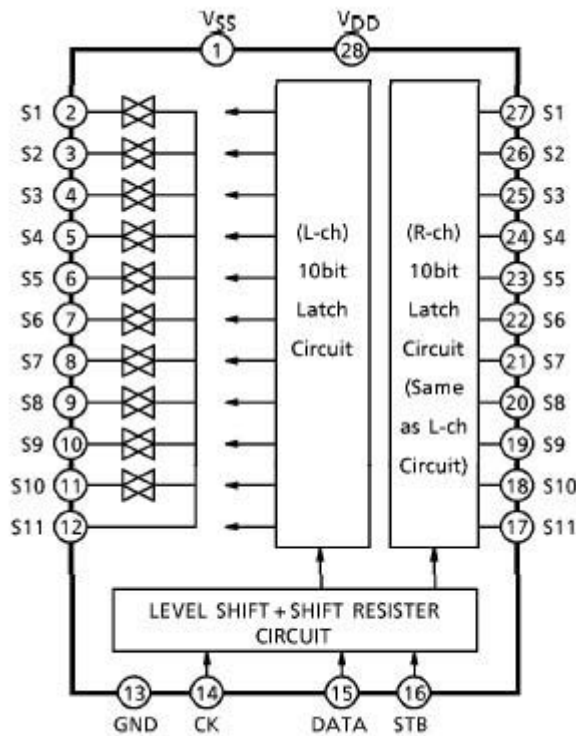
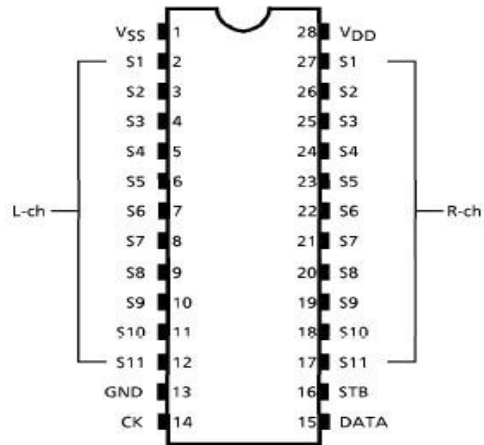
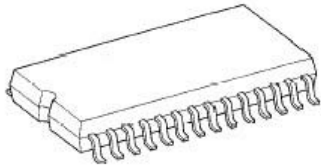

33. TSH95ID (VIDEO: IC23, 28, 31)

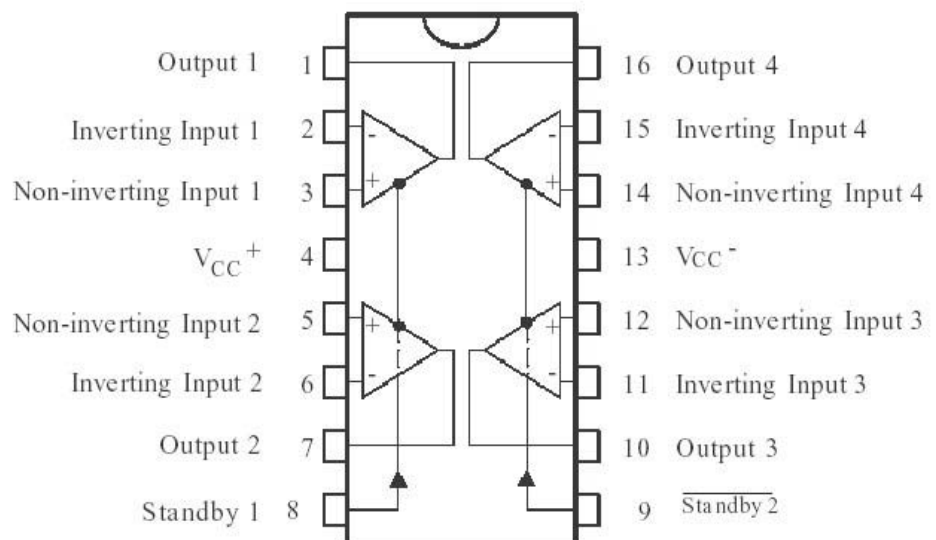
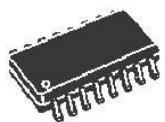

34. SN74LVC1G17DBVR SOT(SOT-23)DBV (DSP: IC2, 39)

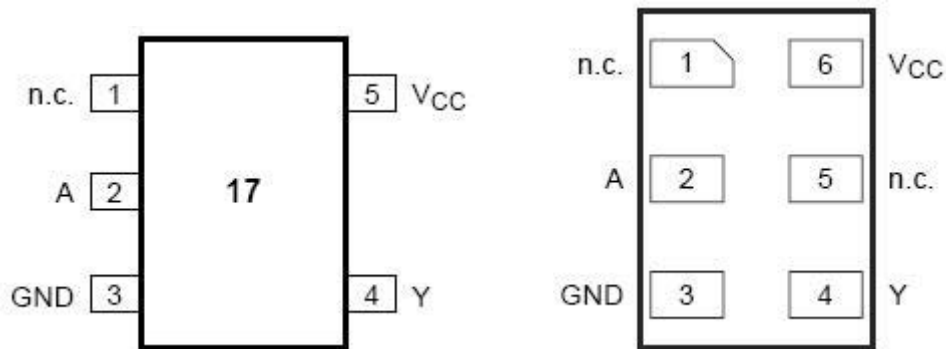

35. SN74LVC257AD (DSP: IC24, 27, 81, 82)
(VIDEO: IC49)

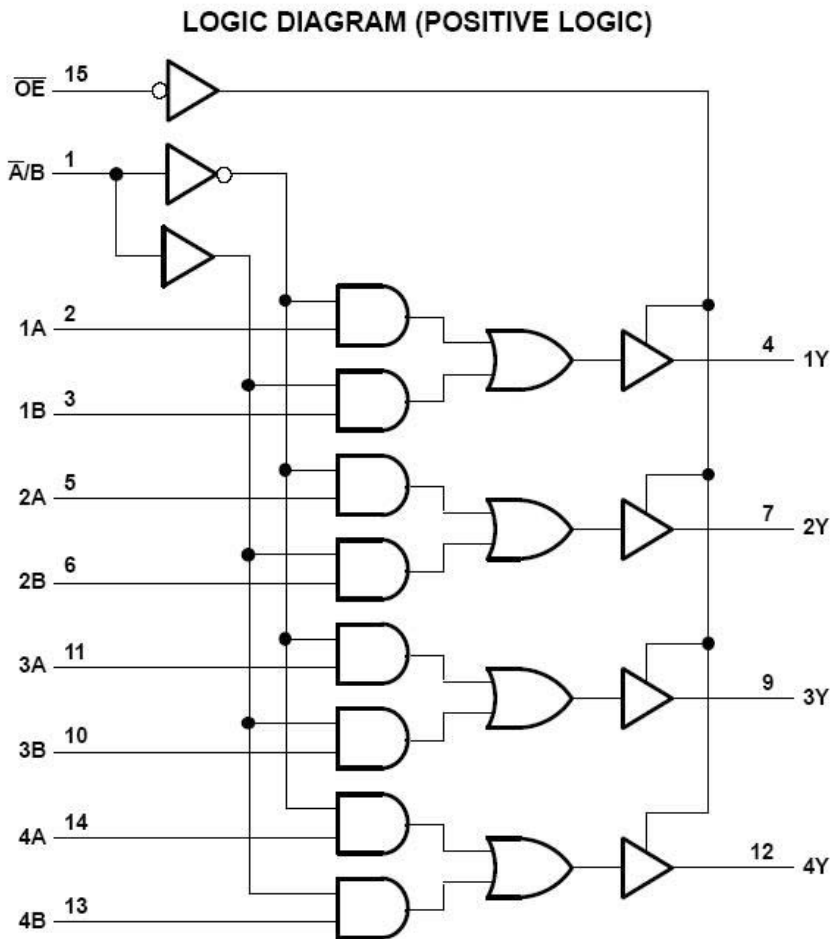

SN54LVC257A ... J OR W PACKAGE
SN74LVC257A ... D, DB, NS,
OR PW PACKAGE
(TOP VIEW)

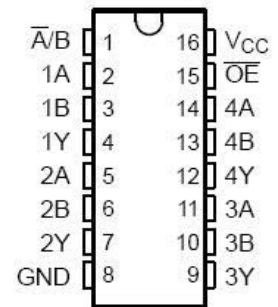

Pin numbers shown are for the D, DB, J, NS, PW, RGY, and W packages.

36. ACF451832-333-T (E901)

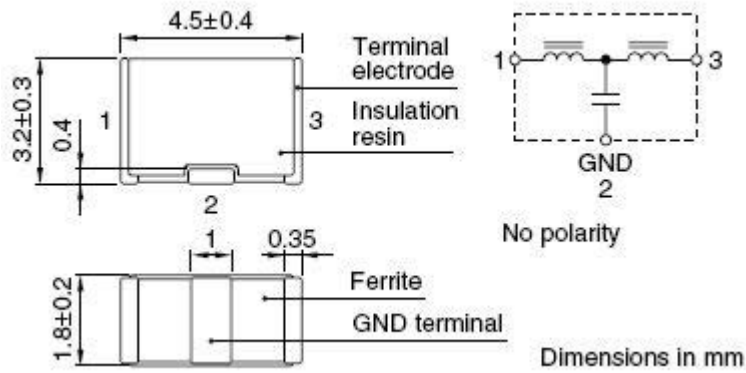

37. CS4391A-KZZ SOP20 (DSP: IC55)

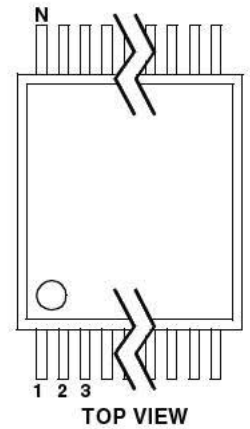
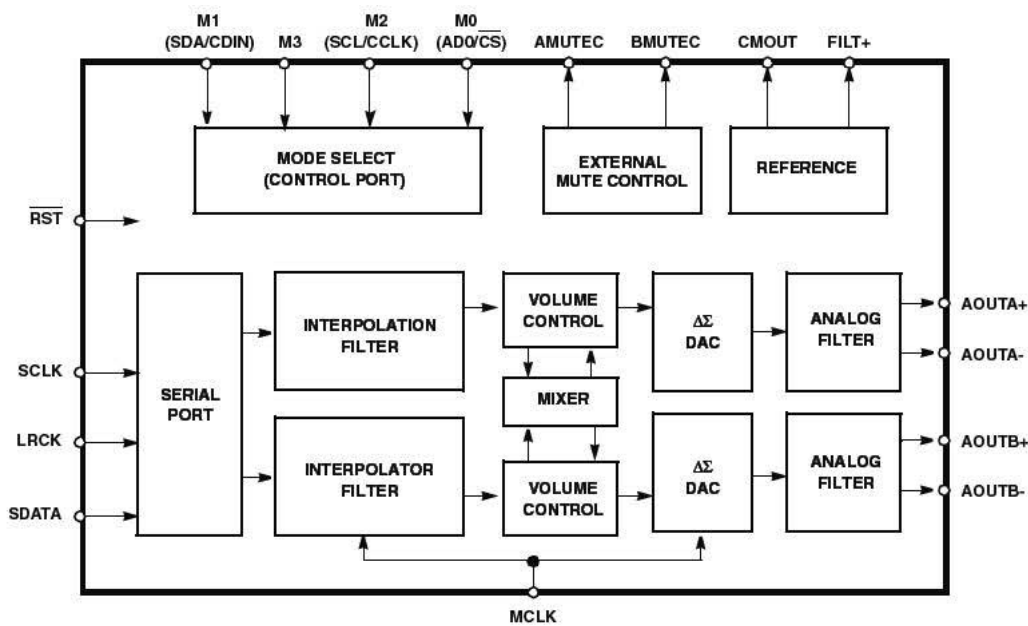

$\overline{\text{RST}}$	1	20	AMUTEC
VL	2	19	AOUTA-
SDATA	3	18	AOUTA+
SCLK	4	17	VA
LRCK	5	16	AGND
MCLK	6	15	AOUTB+
M3	7	14	AOUTB-
(SCL/CCLK) M2	8	13	BMUTEC
(SDA/CDIN) M1	9	12	CMOUT
(AD0/CS) M0	10	11	FILT+

38. ADA4410-6ACPZ (VIDEO: IC40)

Pin No.	Name	Description
1	Pb1/B1_HD	Channel 1 Pb/B High Definition Input
2	GND	Signal Ground Reference
3	Pr1/R1_HD	Channel 1 Pr/R High Definition Input
4	F_SEL_A	Filter Cutoff Select Input A
5	F_SEL_B	Filter Cutoff Select Input B
6	Y2/G2_HD	Channel 2 Y/G High Definition Input
7	GND	Signal Ground Reference
8	Pb2/B2_HD	Channel 2 Pb/B High Definition Input
9	GND	Signal Ground Reference
10	Pr2/R2_HD	Channel 2 Pr/R High Definition Input
11	MUX_SD	Standard Definition Input MUX Select Line
12	Y1_SD	Channel 1 Y Standard Definition Input
13	Y2_SD	Channel 2 Y Standard Definition Input
14	C1_SD	Channel 1 C Standard Definition Input
15	C2_SD	Channel 2 C Standard Definition Input
16	VCC	Positive Power Supply
17	VEE	Negative Power Supply
18	CV_OUT	Composite Video Output
19	C_SD_OUT	C Standard Definition Output
20	Y_SD_OUT	Y Standard Definition Output
21	G_SEL	Gain Select
22	Pr/R_HD_OUT	Pr/R High Definition Output
23	Pb/B_HD_OUT	Pb/B High Definition Output
24	Y/G_HD_OUT	Y/G High Definition Output
25	VEE	Negative Power Supply
26	VCC	Positive Power Supply
27	DISABLE	Disable/Power Down/Logic Reference
28	LEVEL2	DC Level Adjust Pin 2
29	LEVEL1	DC Level Adjust Pin 1
30	MUX_HD	High Definition Input MUX Select Line
31	Y1/G1_HD	Channel 1 Y/G High Definition Input
32	GND	Signal Ground Reference

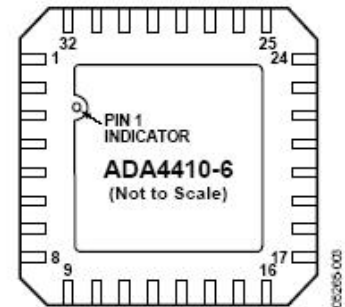

39. ADA4412-3ARQZ (VIDEO: IC39)

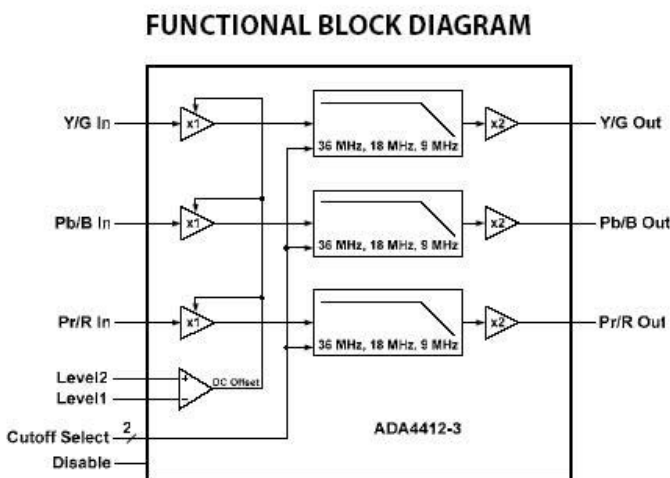
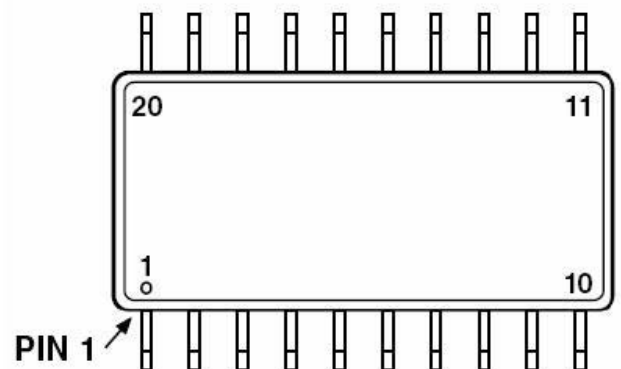
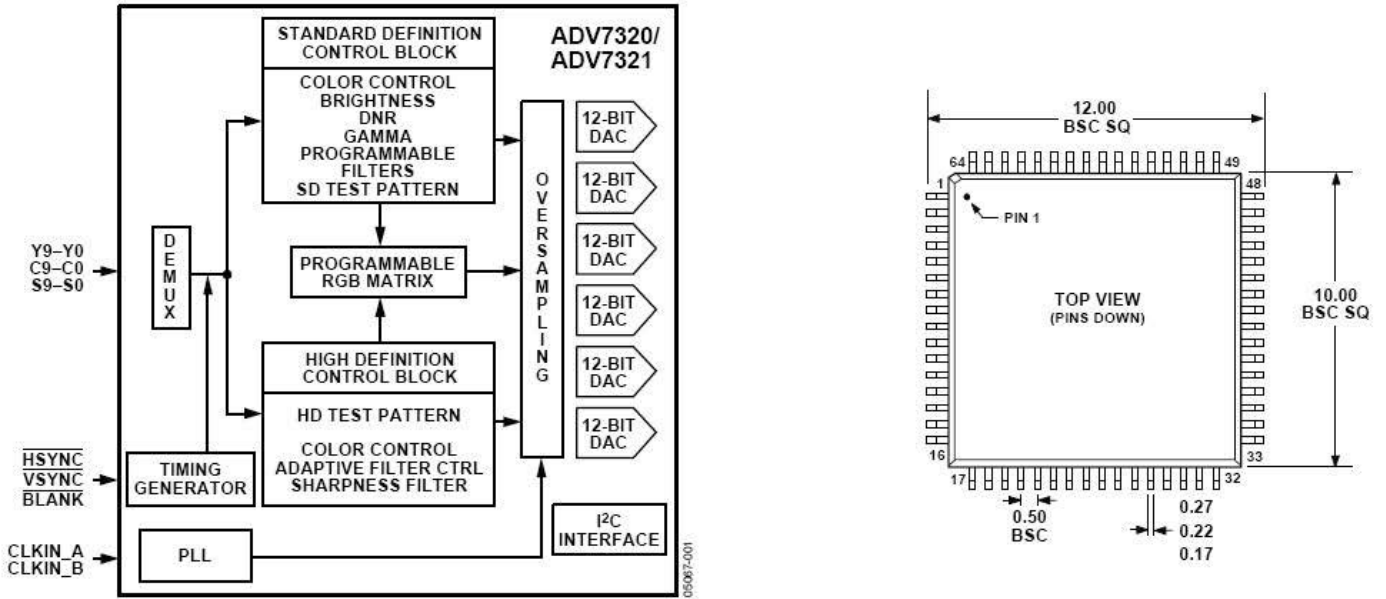

Figure 1.



40. DV7320LKSTZ (VIDEO: IC29)



41. AD1580BRTZ (VIDEO: IC64)

3-Lead Small Outline Transistor Package [SOT-23-3] (RT-3)

Dimensions shown in millimeters

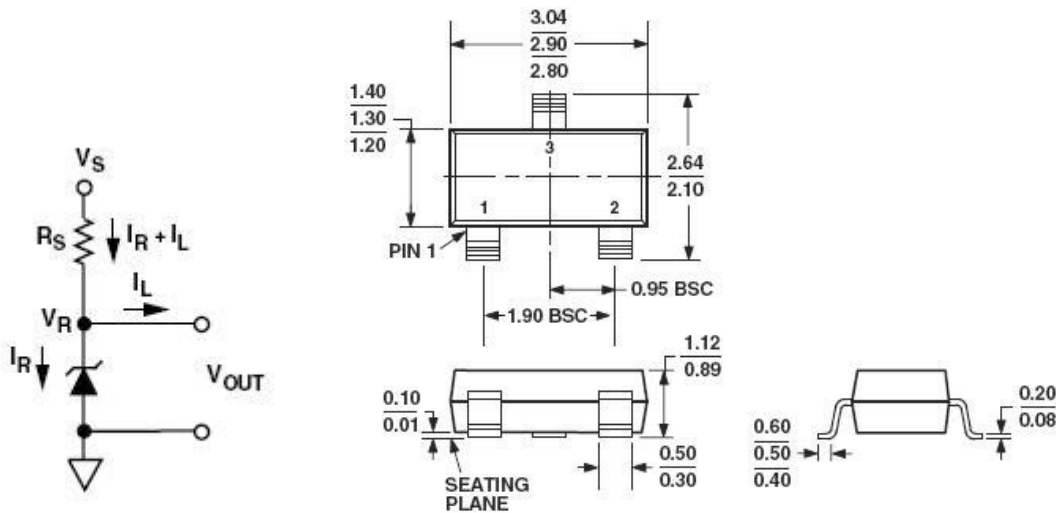

42. SDRAMK4S643232H (VIDEO: IC48)

FUNCTIONAL BLOCK DIAGRAM

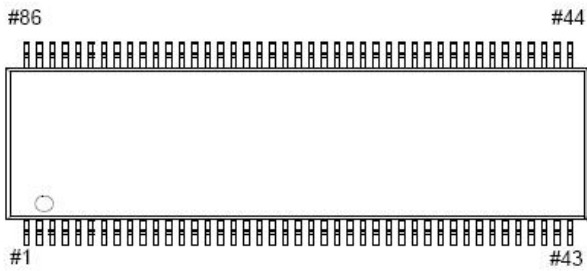
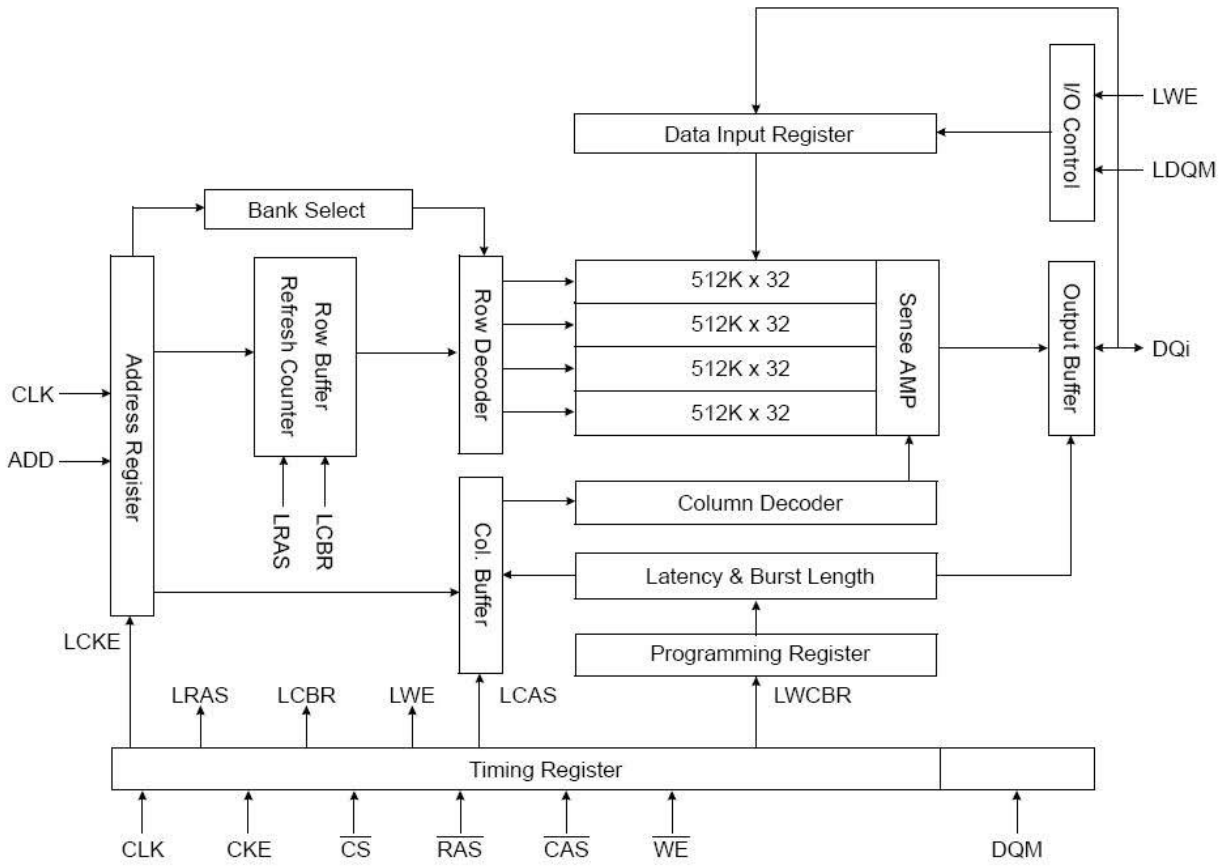

43. ADV7401BSTZ (VIDEO: IC24)

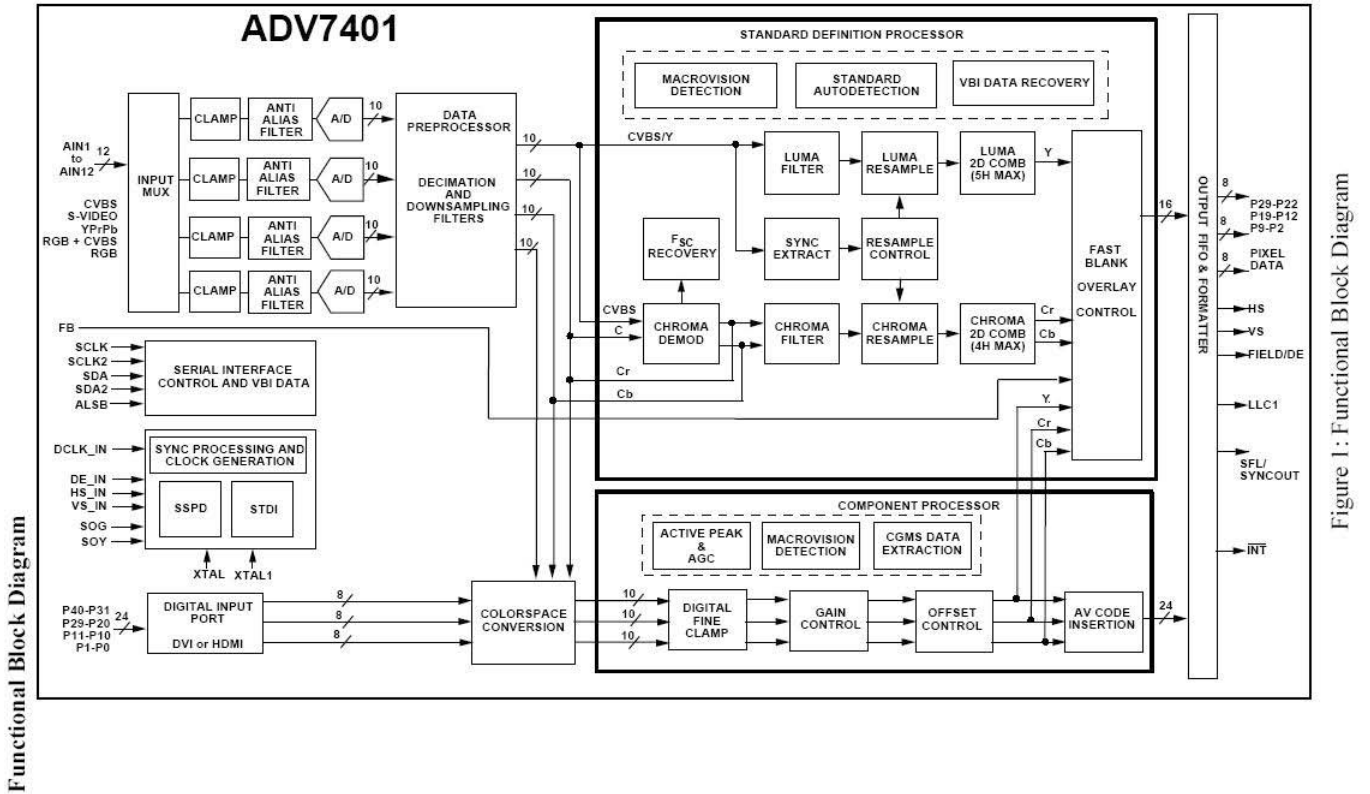
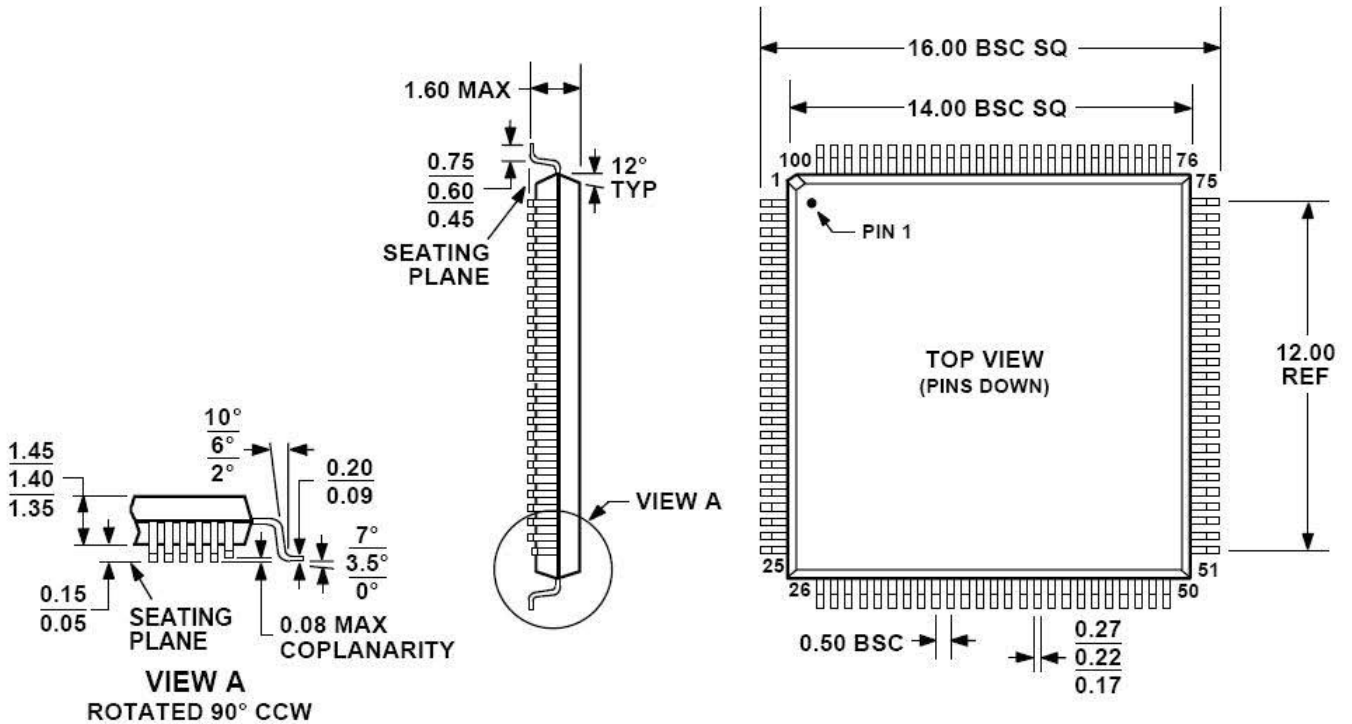
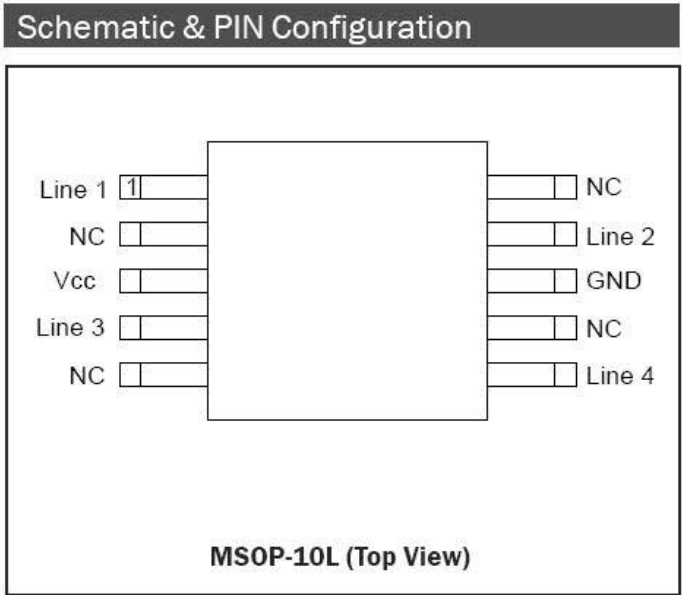
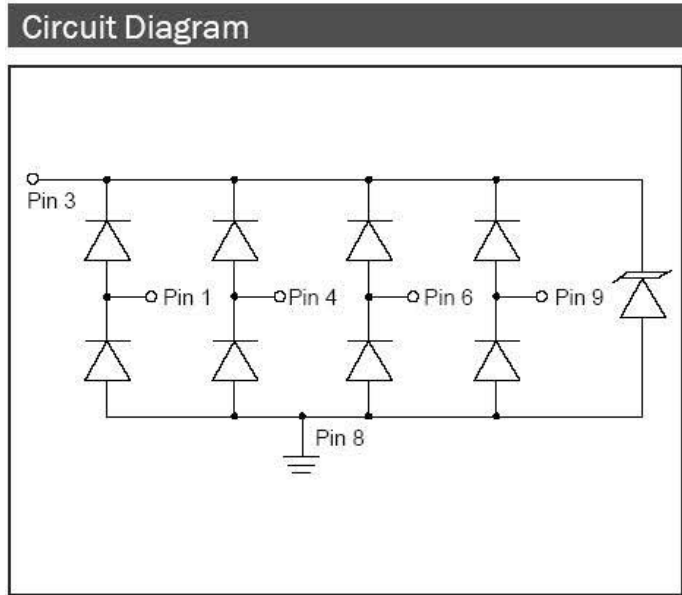

Figure 1: Functional Block Diagram



COMPLIANT TO JEDEC STANDARDS MS-026BED

44. RCLAMP0514M (VIDEO: IC56 IC57 IC61 IC62)



45. 2N7002LT1G (VIDEO: Q119 Q120 Q121 Q122)

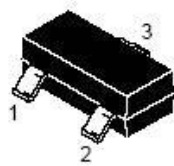
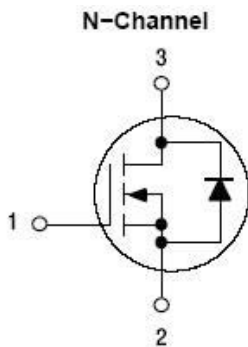

**SOT-23
CASE 318
STYLE 21**

**MARKING DIAGRAM
& PIN ASSIGNMENT**

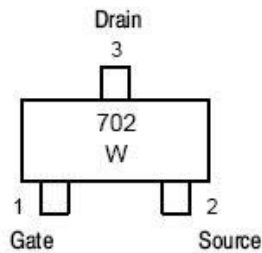

702 = Device Code
W = Work Week

46. UPA672T (VIDEO: IC41 IC44 IC58)

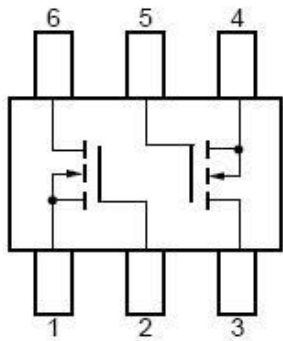

- 1. Source 1 (S1)
 - 2. Gate 1 (G1)
 - 3. Drain 2 (D2)
 - 4. Source 2 (S2)
 - 5. Gate 2 (G2)
 - 6. Drain 1 (D1)
- Marking: MA

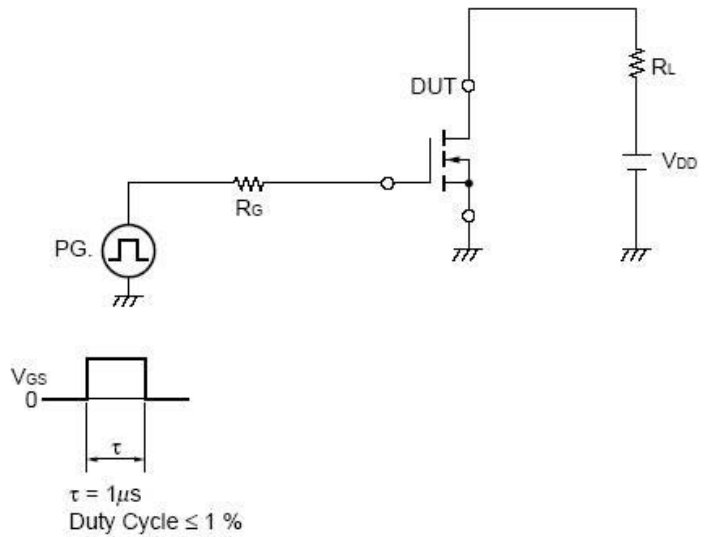

47. SN74CB3T3306DCTR (DSP: IC5 VIDEO: IC66)

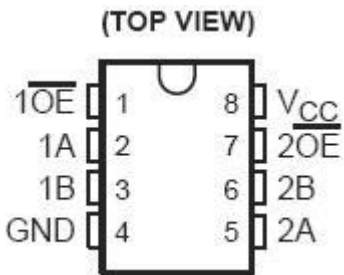

FUNCTION TABLE
(each bus switch)

INPUT \overline{OE}	INPUT/OUTPUT A	FUNCTION
L	B	A port = B port
H	Z	Disconnect

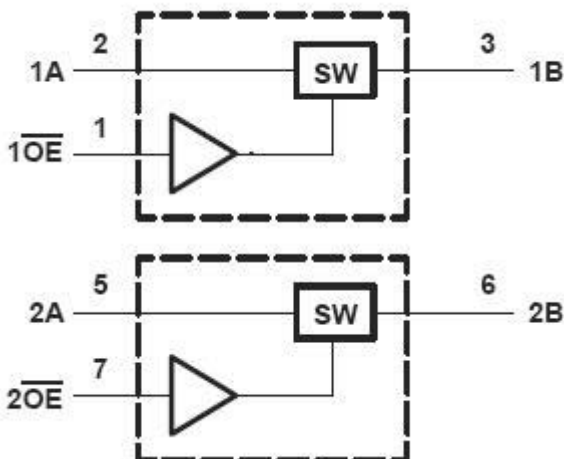
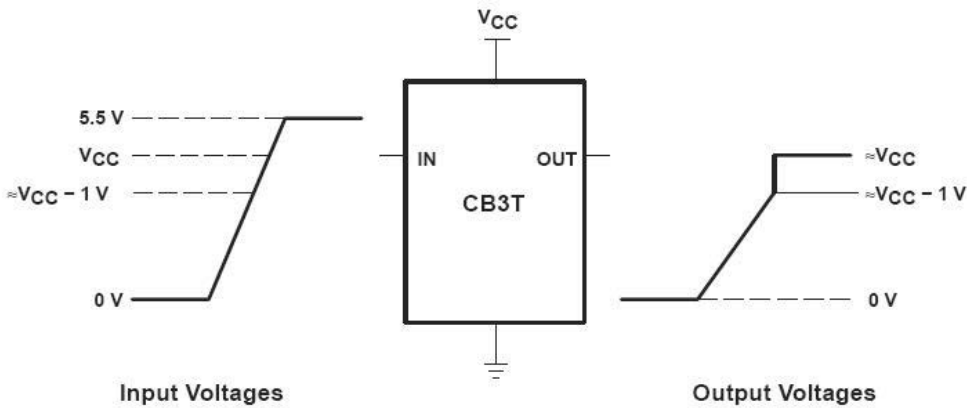

48. FLI2300-BD PQFP-208 (VIDEO: IC47)

Figure 2.1: FLI2300– Simplified Internal Block Diagram

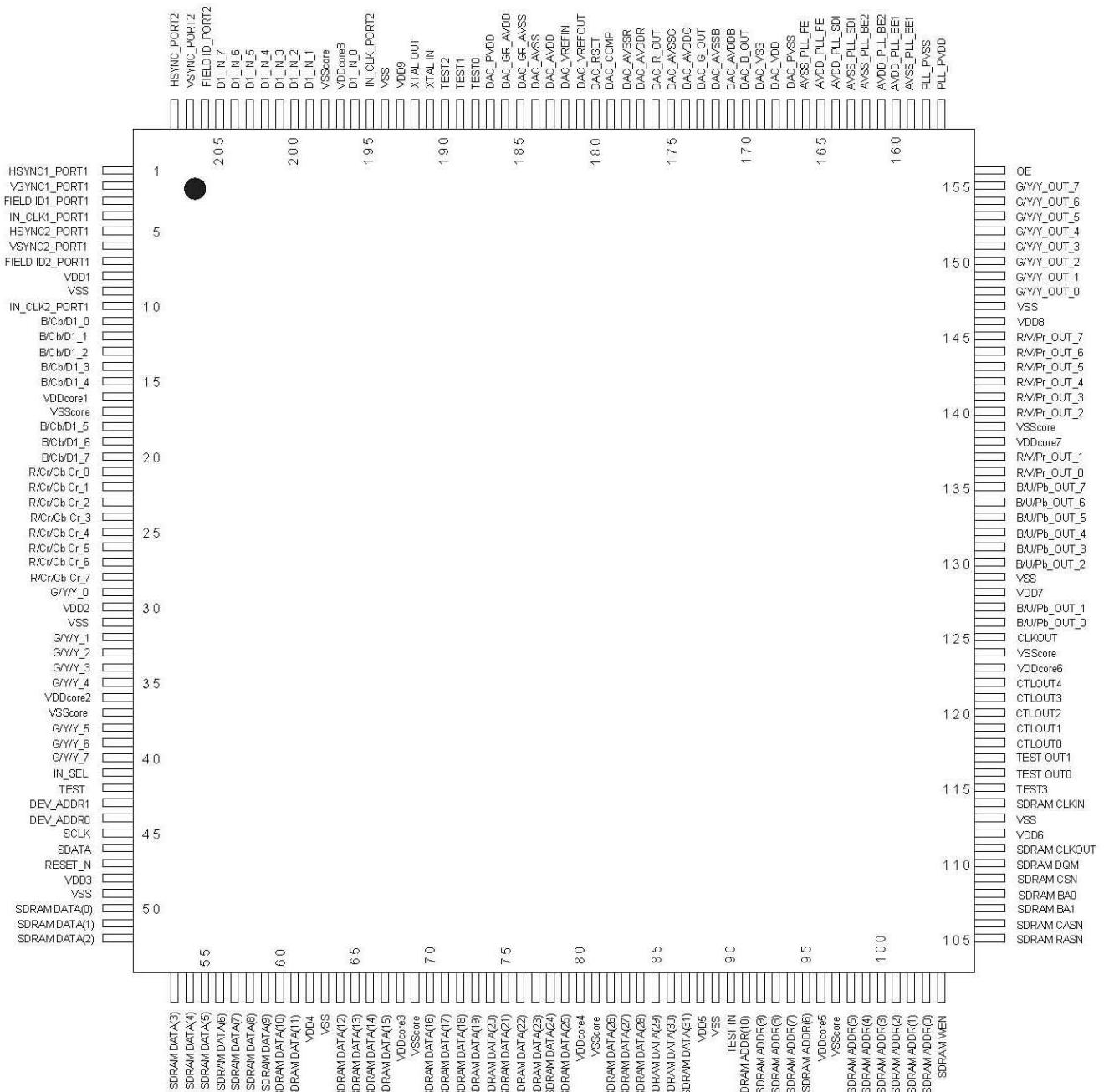
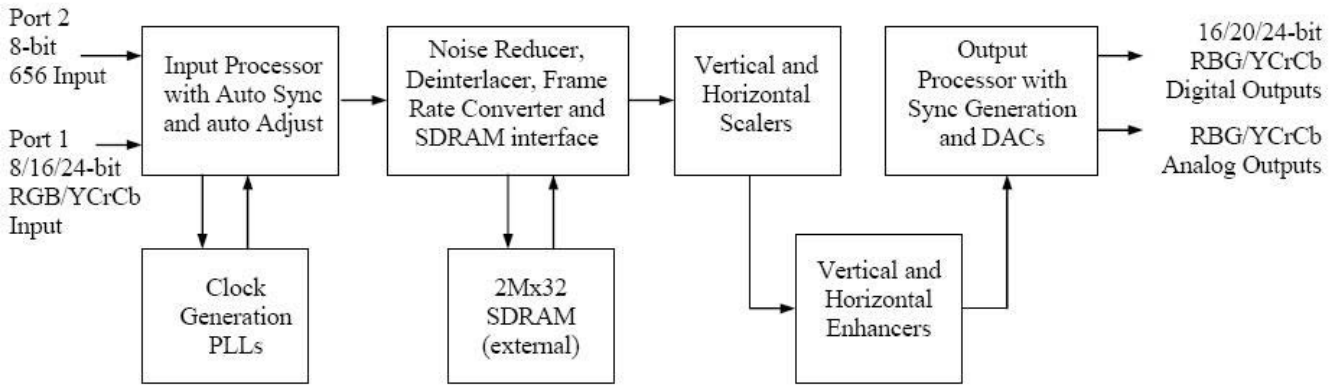

49. UPD70F3261YGC-8EA-A LQFP100 (DSP: IC11)

Internal block diagram

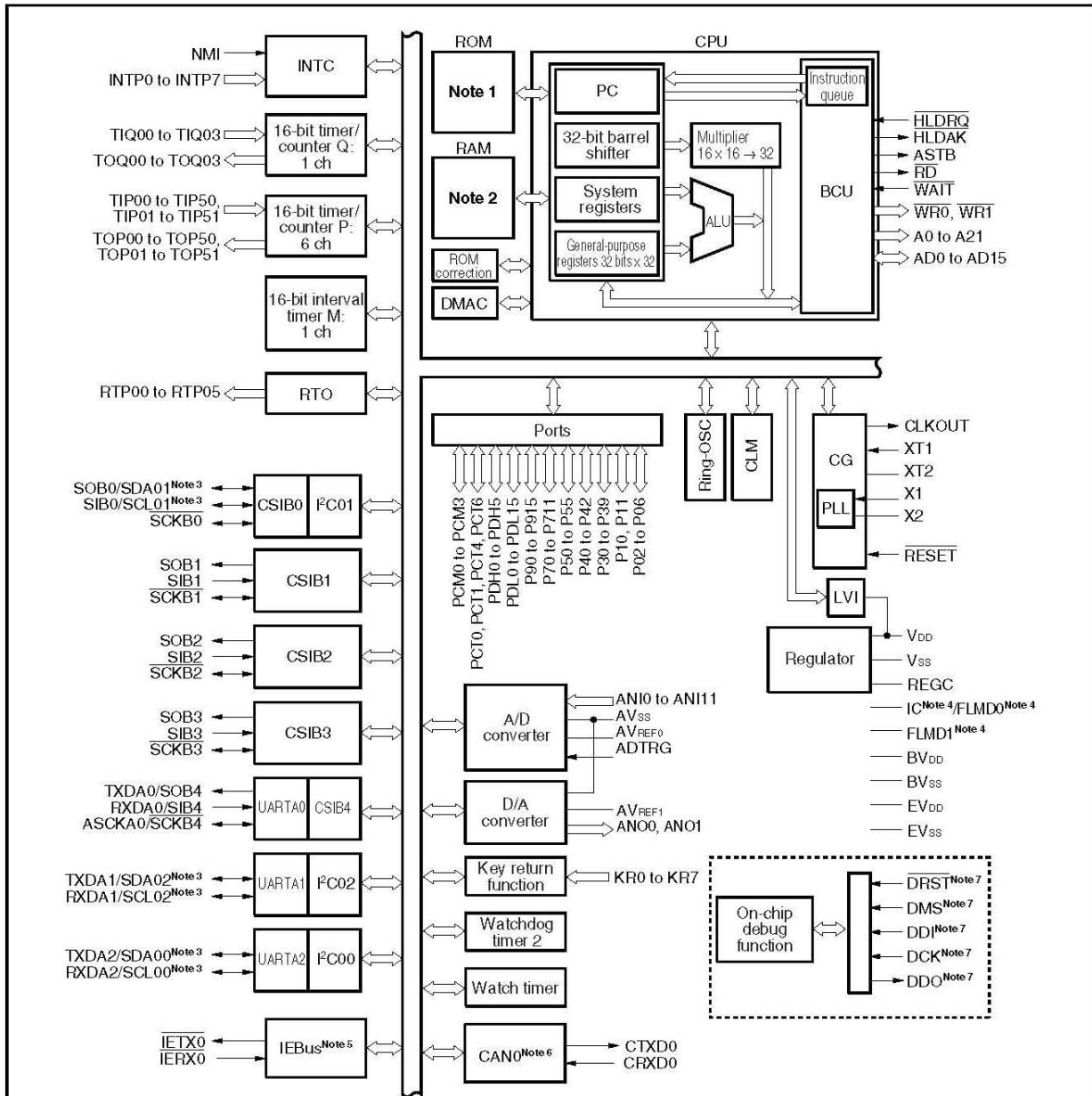

- Notes 1.** 256/384/512/640 KB (mask ROM) (see Table 1-1)
 384/640 KB (flash memory) (see Table 1-1)
- 2.** 24/32/40/48 KB (see Table 1-1)
- 3.** I²C bus version (Y version) only
- 4.** IC: Mask ROM version only
 FLMD0, FLMD1: Flash memory version
- 5.** IEBus controller version only
- 6.** CAN controller version only
- 7.** Flash memory version only

UPD70F3261YGC-8EA-A LQFP100

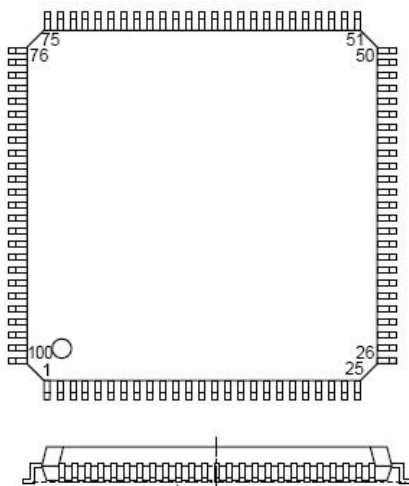
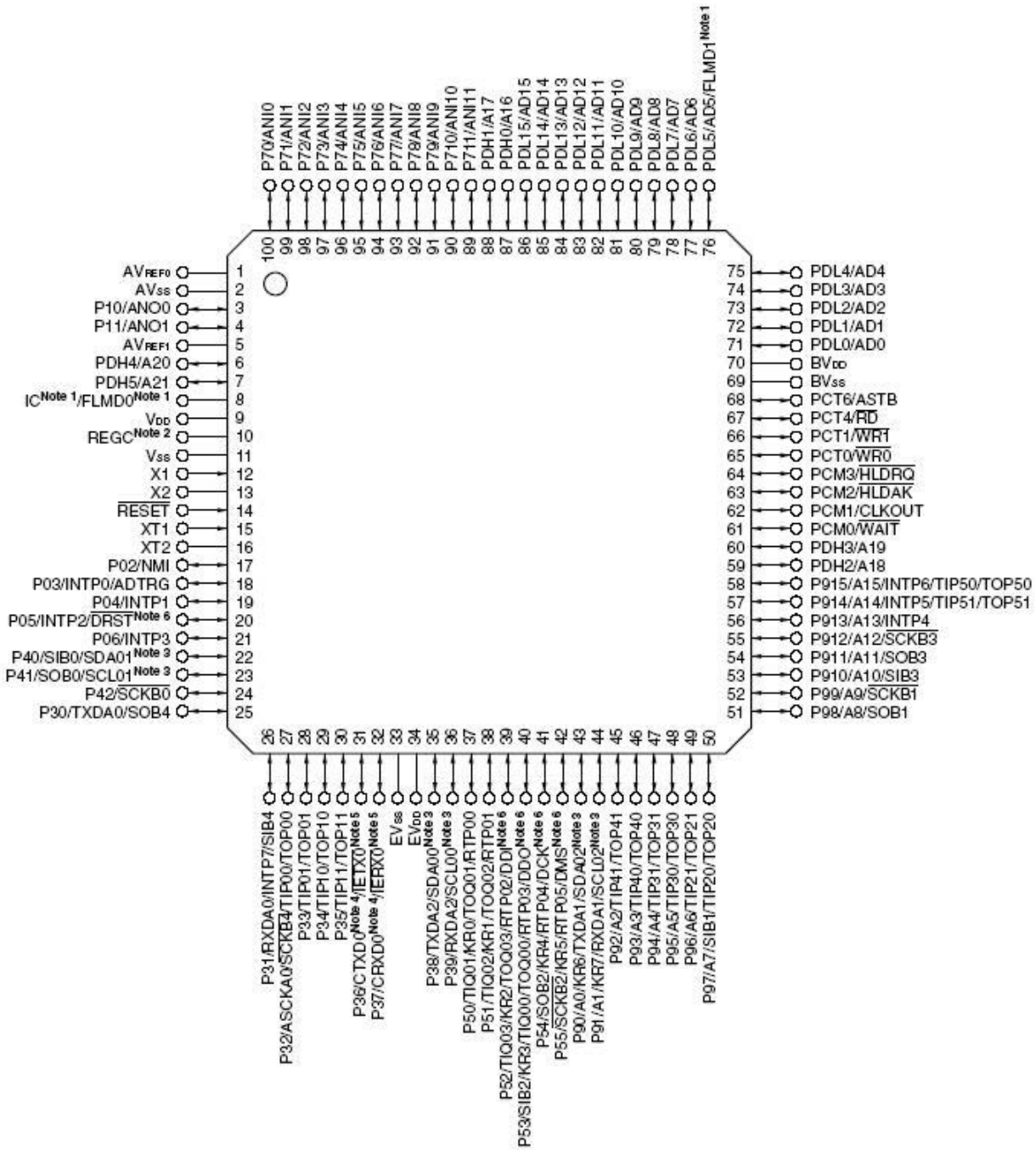

50. SII9030CTU TQFP80 (VIDEO: IC54)

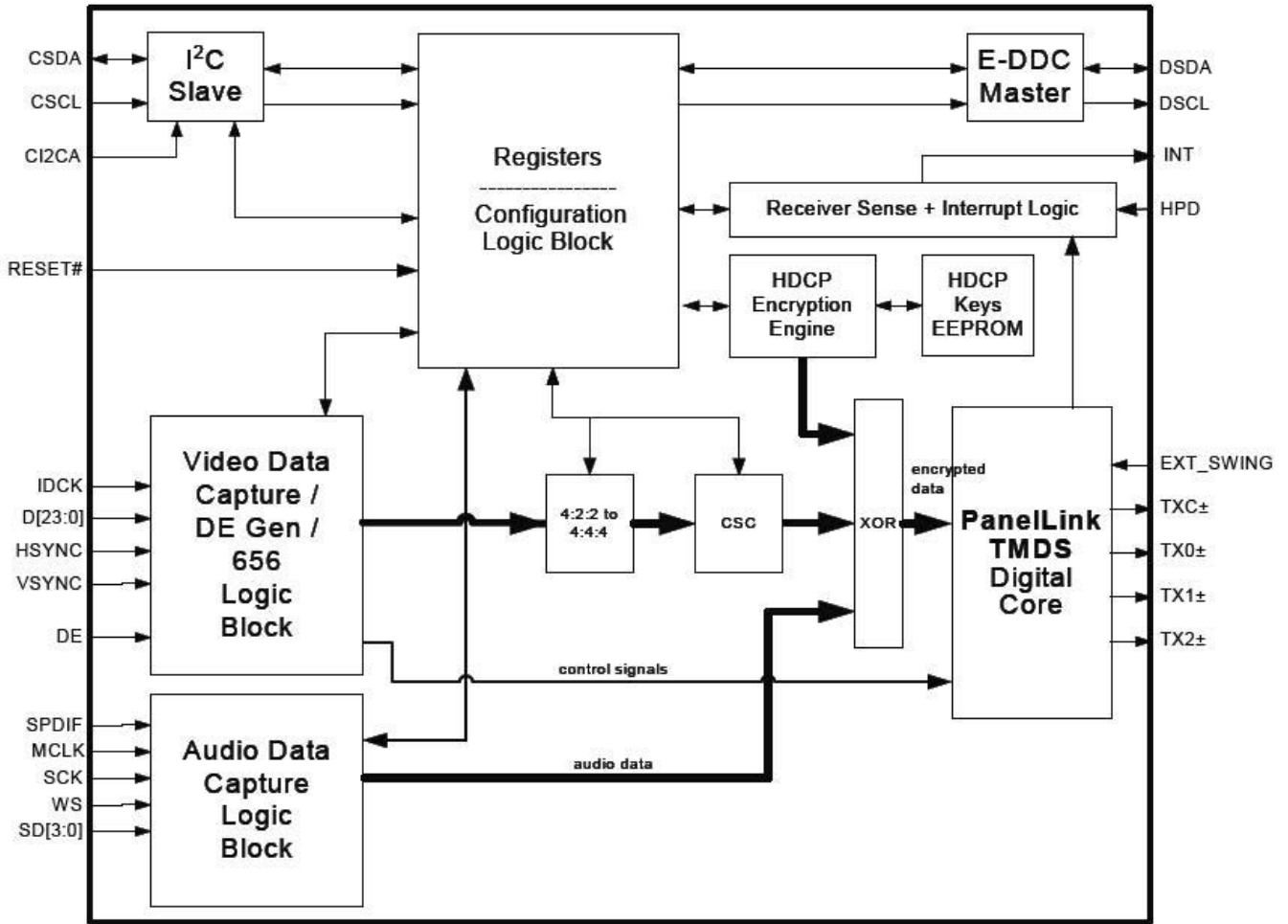
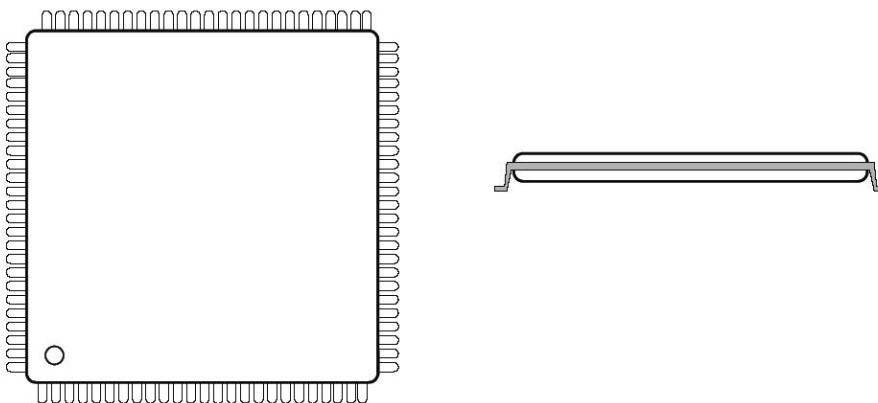

Figure 2. Functional Block Diagram



51. SIL9031CTU TQFP144 (VIDEO: IC55)

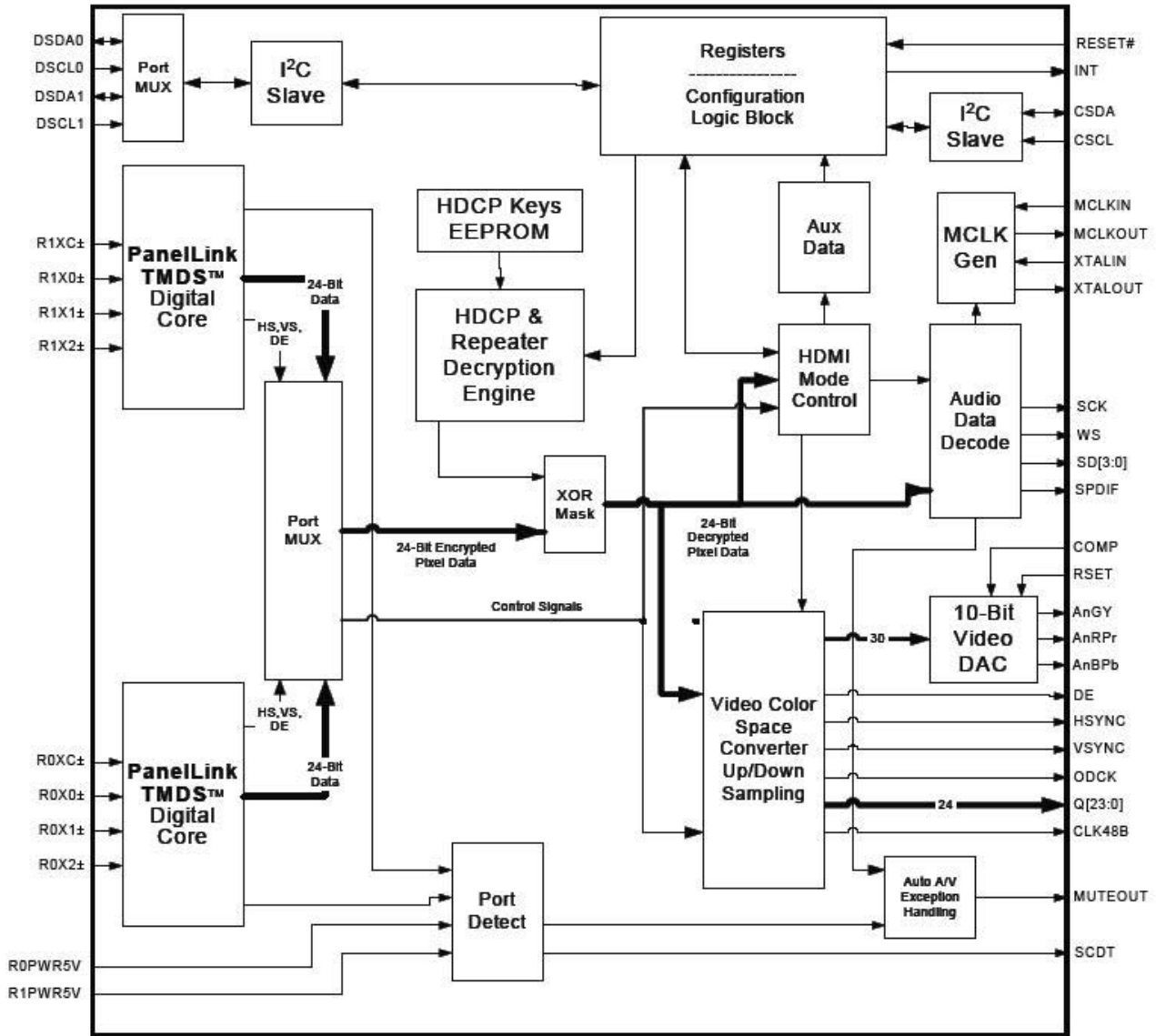
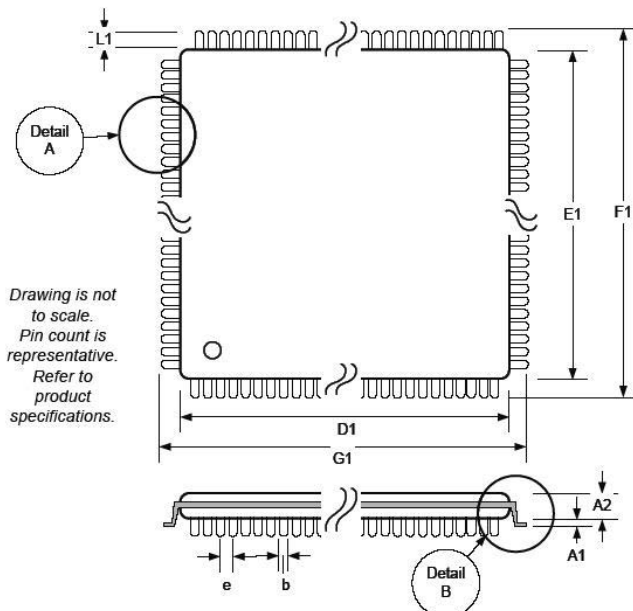
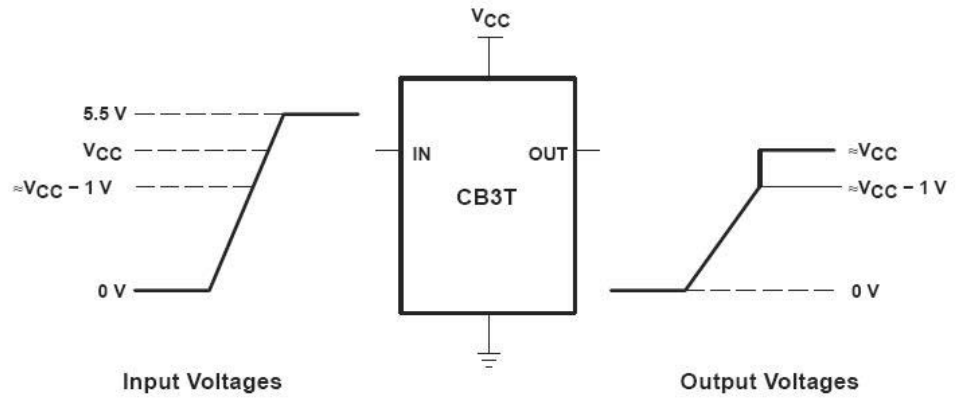
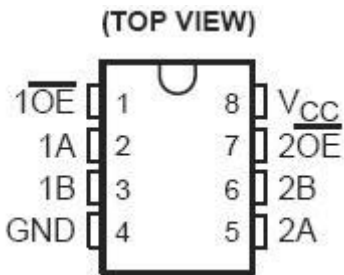

Figure 3. Functional Block Diagram

144-pin TQFP Package Dimensions



52. SN74CB3T3306DCTR SSOP-8 (DSP: IC96)



FUNCTION TABLE
(each bus switch)

INPUT \overline{OE}	INPUT/OUTPUT A	FUNCTION
L	B	A port = B port
H	Z	Disconnect

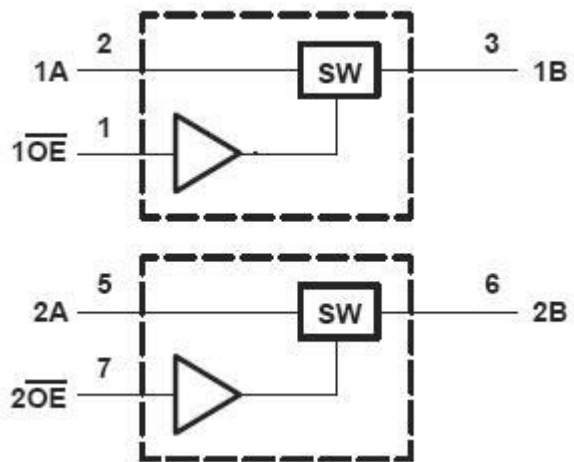

53. CS5368-CQZ LQFP48 (DSP: IC54)

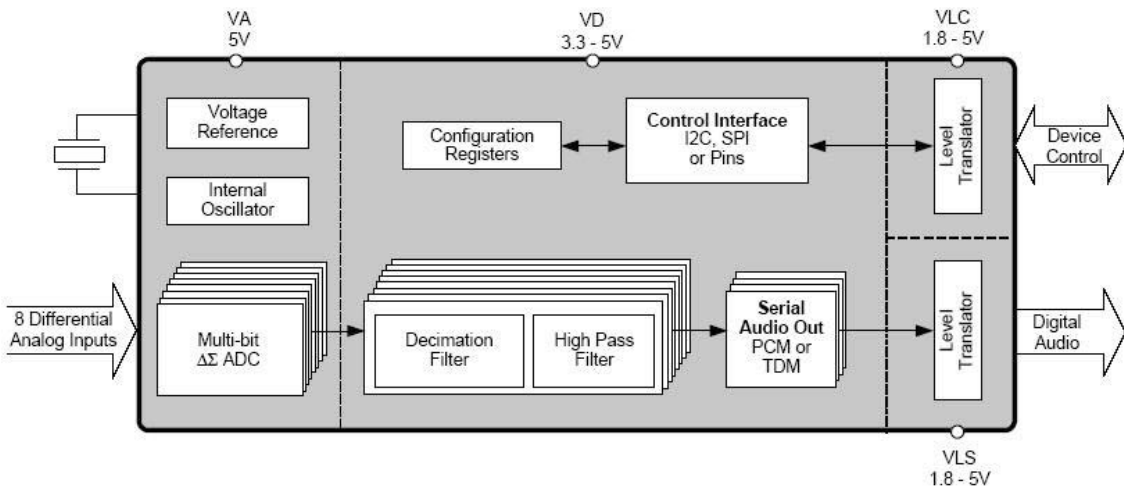
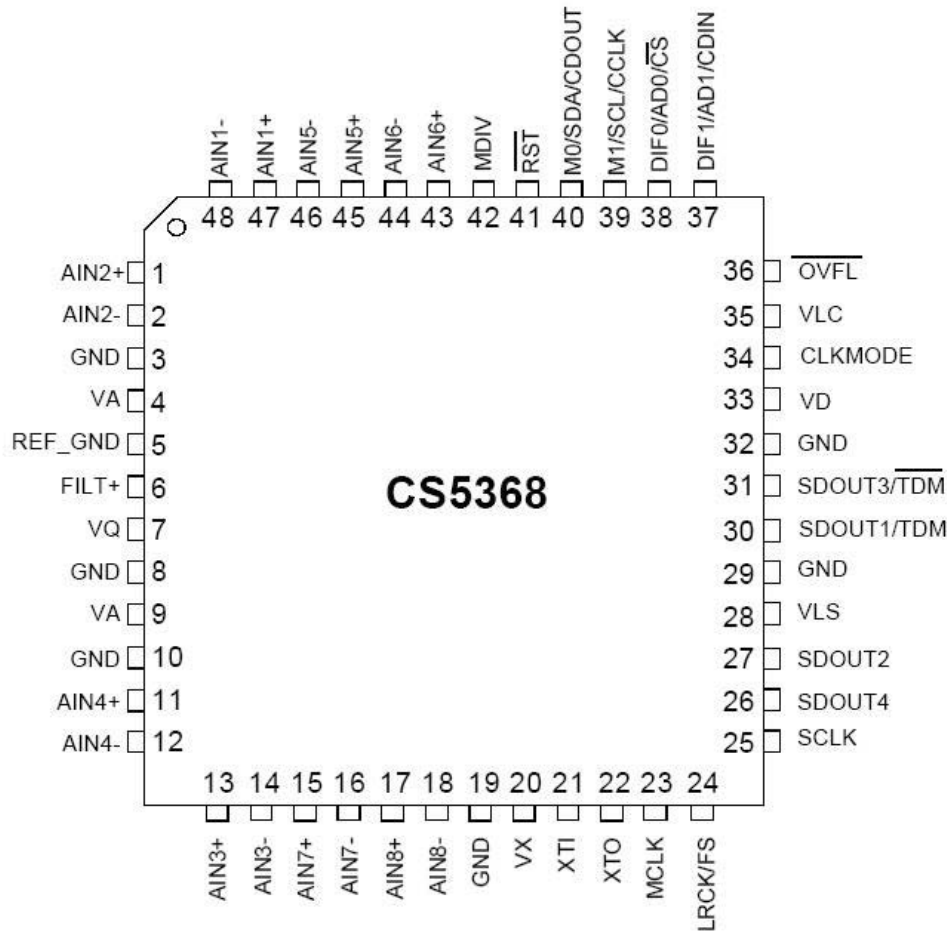

54. CS42528-CQZ-D (DSP: IC31)

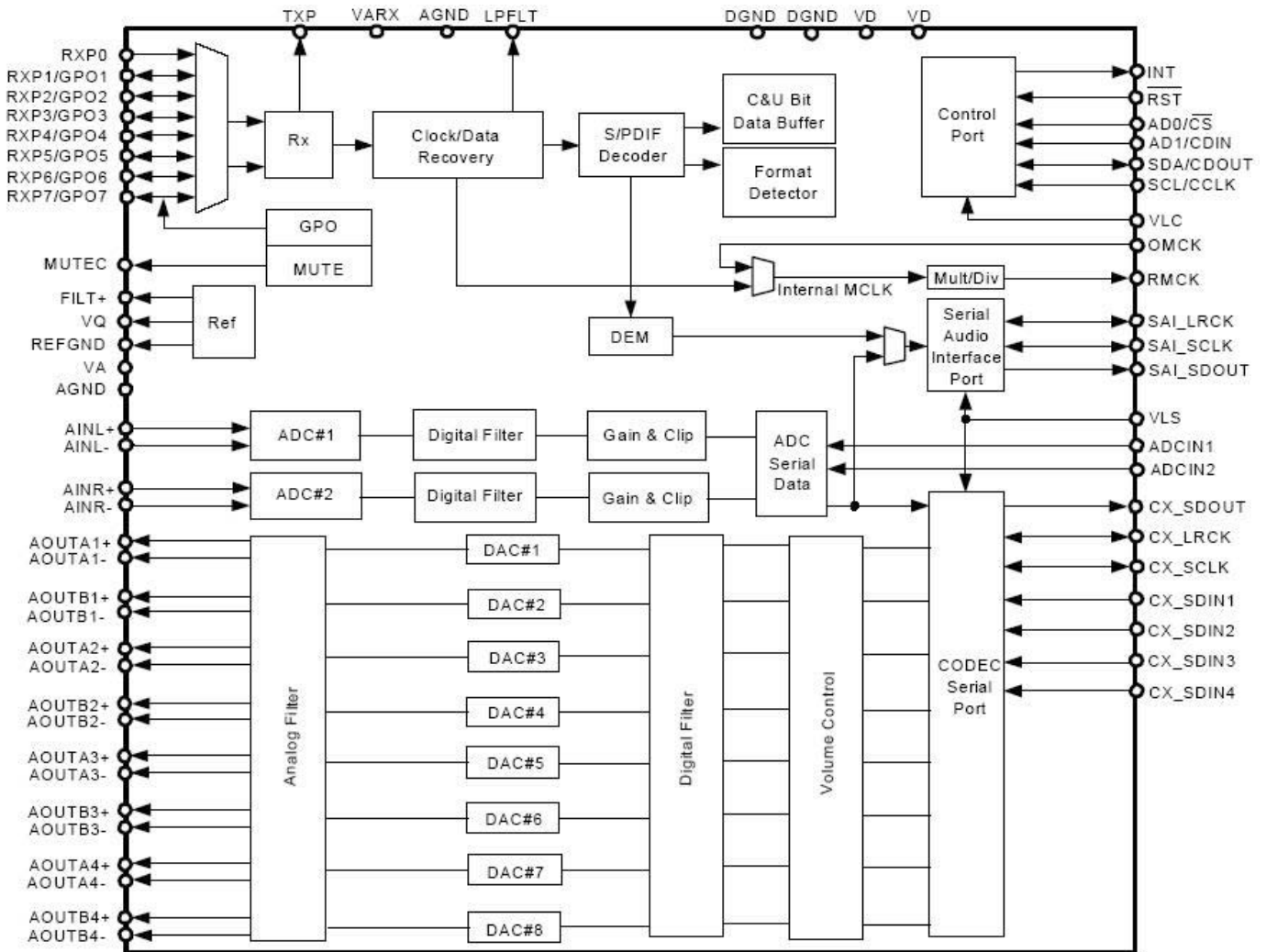

55. CJT117-3.3 (VIDEO: IC11)
 CJT117-2.5 (VIDEO: IC65)
 IL1117S-1.8 (VIDEO: IC10)

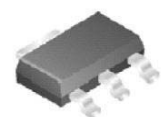
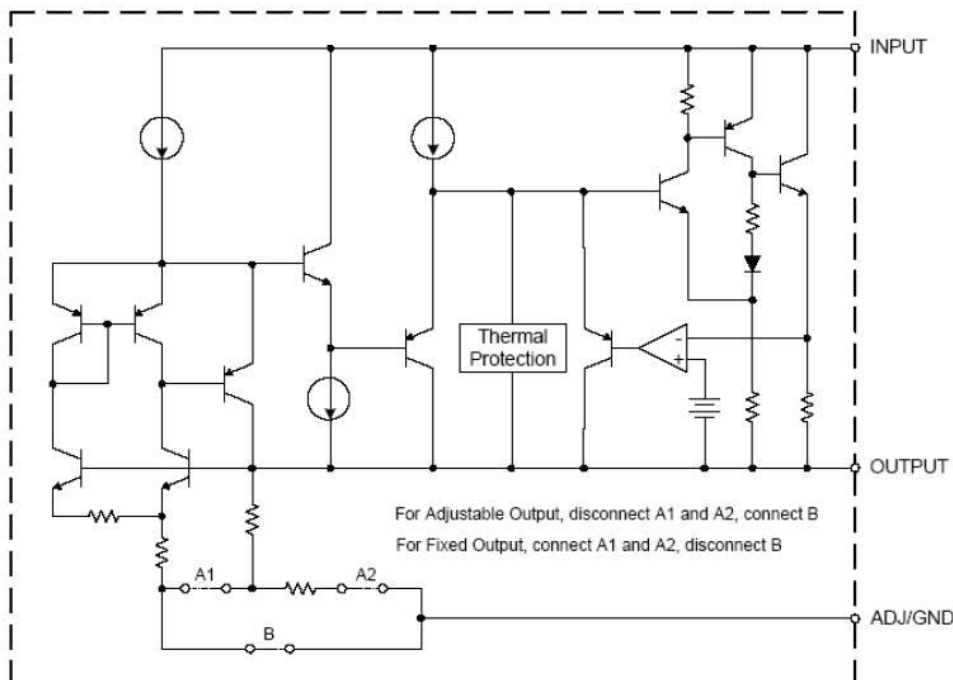

SOT-223

- 56. KIA278R33API (MAIN: IC71)
- KIA278R06API (MAIN: IC73)
- KIA378R05PI (SURROUND: IC64)

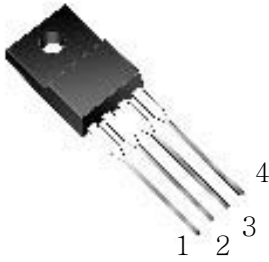

- ① DC INPUT (V_{IN})
- ② DC OUTPUT (V_O)
- ③ GND
- ④ ON/OFF CONTROL

- 57. KIA7805API (MAIN: IC72 SUPPLY: IC12)
- KIA7812API (MAIN: IC59)
- KIA7815API (MAIN: IC51, 60)
- KIA7824API (MAIN: IC54)
- KIA7806AP (VIDEO: IC30)
- KIA78D33PI (SUPPLY: IC11 SURROUND: IC61)



- 1. INPUT
- 2. COMMON
- 3. OUTPUT

- 58. KIA7915API (MAIN: IC52)
- KIA7905PI (SURROUNDY: IC63)



- 1. COMMON
- 2. INPUT
- 3. OUTPUT

TRANSISTORS

1. KRA107S

(DSP: Q113)

(FRONT: Q824, 831, 832)

(PROCESSOR: Q109, 203, 301, 605, 608, 611, 614, 615, 618, 620, 623, 626
629, 754, 692, 751)

(SUPPLY: Q301, 302)

(VIDEO: Q110, 111, 112)

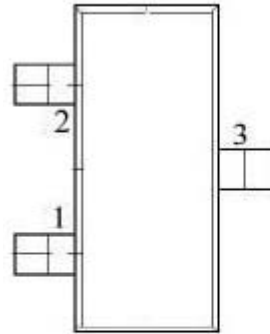
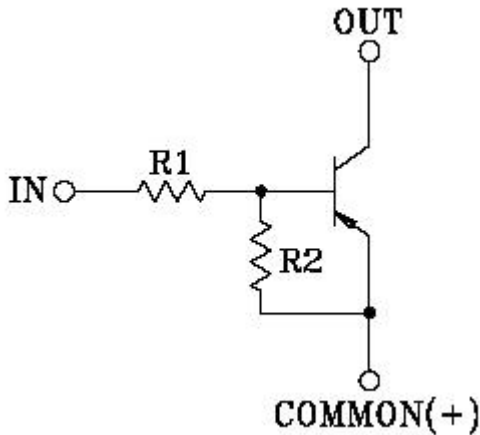

- 1. COMMON (EMITTER)
- 2. IN (BASE)
- 3. OUT (COLLECTOR)

2. KRC107S

(DSP: Q1 Q2 Q3 Q4 Q101 Q102 Q103 Q104 Q105 Q106 Q107 Q108
Q109 Q110 Q201 Q301 Q303)

(FRONT: Q800, 801, 802, 803, 820, 822, 833)

(SUPPLY: Q303, 304)

(VIDEO: Q103, 104, 105, 106, 113, 114, 115, 118)

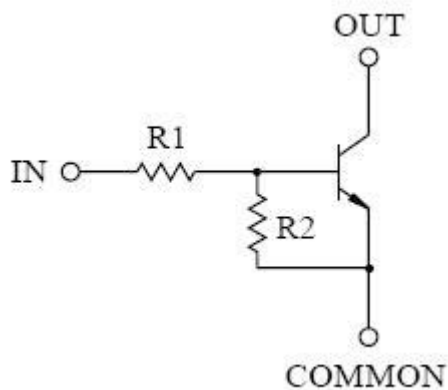

3. KTA1504Y (SUPPLY: Q305 Q306)

(FRONT: Q703)

(PROCESSOR: Q601, 602, 621, 622, 624, 625, 627, 628, 630, 631, 104, 105, 107, 108, 201, 202, 204, 205, 221, 222, 302, 303, 603, 604, 606, 607, 609, 610, 612, 613, 616, 617, 690, 691, 752, 753)

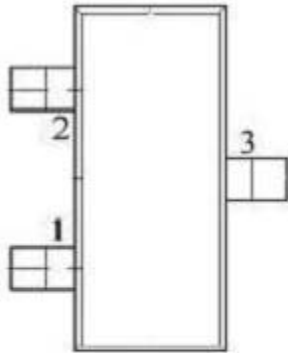

- 1. COMMON (EMITTER)
- 2. IN (BASE)
- 3. OUT (COLLECTOR)

4. KTC3875S (FRONT: Q701 Q702)

(VIDEO: Q101)

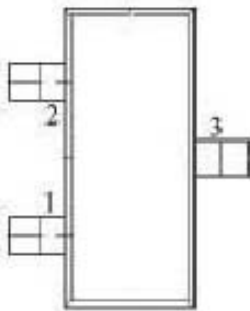

- 1. COMMON (EMITTER)
- 2. IN (BASE)
- 3. OUT (COLLECTOR)

5. KTC3199-GR (VIDEO: Q100 Q102)

KTA1267-GR (VIDEO: Q107 Q108 Q109)

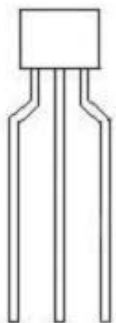

- (1) Emitter
- (2) Collector
- (3) Base

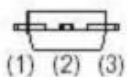

6. KTA1360 (MAIN: Q327 Q328 Q431 Q432 -AVR745,645 ONLY) SURROUND: Q215 Q315 Q515)
 KTA1360 (MAIN: Q417 Q418 Q315 Q316 -AVR445 ONLY) SURROUND: Q208 Q508 Q308)
 KTC3114 (MAIN: Q701 Q702 Q703 Q704 SURROUND: Q214 Q314 Q514)
 KTC3423 (MAIN: Q323 Q324 Q429 Q430 SURROUND: Q213 Q313 Q513)
 -AVR745,645 ONLY
 KTC3423 (MAIN: Q419 Q420 Q317 Q318 SURROUND: Q209 Q509 Q309)
 -AVR445 ONLY



1. EMITTER
2. COLLECTOR
3. BASE

7. 2SA1859A (MAIN: Q329 Q330 Q433 Q434 SURROUND: Q216 Q316 Q516)
 2SC4883A (MAIN: Q331 Q332 Q435 Q436 SURROUND: Q217 Q317 Q517)



1. BASE
2. COLLECTOR
3. EMITTOR

8. KTA1268BL (MAIN: Q311 Q312 Q410 Q413 Q414 SURROUND: Q101 Q206 Q306 Q506)
 KTC3198BL (MAIN: Q307 Q308 Q407 Q408 Q426 Q441 SURROUND: Q204 Q304 Q504)
 KTC3200BL (MAIN: Q301 Q302 Q303 Q304 Q305 Q306 Q313 Q314 Q337 Q338 Q401 Q402
 Q403 Q404 Q405 Q406 Q409 Q415 Q416 Q425)
 (SURROUND: Q201 Q202 Q203 Q207 Q220 Q301 Q302 Q303 Q307 Q320
 Q501 Q502 Q503 Q507 Q520)
 KTD1302 (MAIN: Q601)
 MPSA06 (DSP: Q112 FRONT: Q821 SUPPLY: Q102, Q102)
 MPSA56 (FRONT: Q823)



1. EMITTER
2. COLLECTOR
3. BASE

9. KTA1024Y (MAIN: Q315 Q316 Q319 Q320 Q417 Q418 Q421 Q422 Q442
 SURROUND: Q208 Q211 Q308 Q311 Q508 Q511)-AVR745,645 ONLY
 KTC3206Y (MAIN: Q317 Q318 Q321 Q322 Q419 Q420 Q423 Q424
 SURROUND: Q209 Q212 Q309 Q312 Q509 Q512)-AVR745,645 ONLY



- 1. EMITTER
- 2. COLLECTOR
- 3. BASE

10. KRA107M (DSP: Q851 SUPPLY: Q301, 302)
 KRC107M (MAIN:C443)



- 1. EMITTER
- 2. COLLECTOR
- 3. BASE

11. 2SA1145Y (MAIN: Q309 Q310 Q411 Q412 SURROUND: Q205 Q305 Q505)

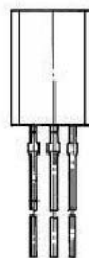
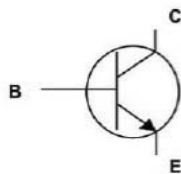

- 1. EMITTER
- 2. COLLECTOR
- 3. BASE

- 12. 2SA1986-R (MAIN: Q335 Q336 Q439 Q440
SURROUND: Q219 Q319 Q519)-AVR745,645 ONLY
- 2SC5358-R (MAIN: Q333 Q334 Q437 Q438
SURROUND: Q218 Q318 Q518)-AVR745,645 ONLY
- 2SD2560 (MAIN: Q333 Q334 Q437 Q438
SURROUND: Q218 Q318 Q518)-AVR445 ONLY
- 2SB1647 (MAIN: Q335 Q336 Q439 Q440
SURROUND: Q219 Q319 Q519)-AVR445 ONLY

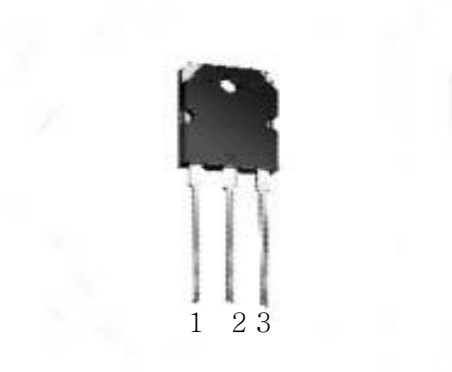

1.BASE
2.COLLECTOR
3.EMITTOR

2SD2560

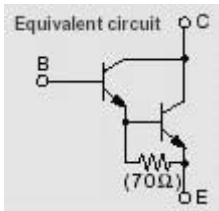

2SB1647

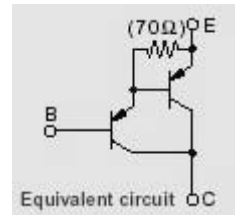

- 13. LM19CIZ 2.4V TO-92
(DSP: PO91 MAIN: PO71)

TO-92

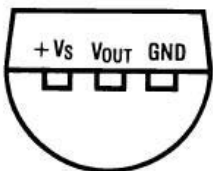

BOTTOM VIEW

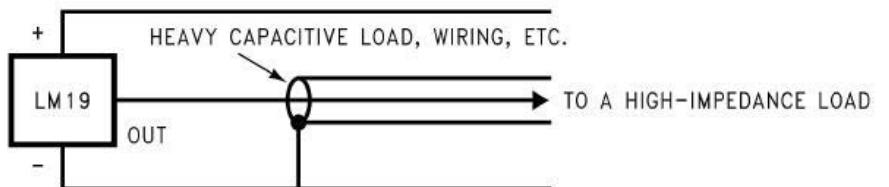

2. VCXO 24M576HZ (DSP Y201)

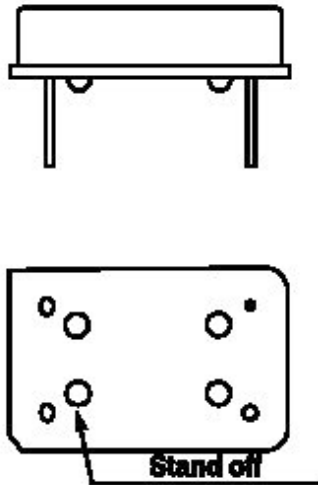

<14 PIN DIP>

PIN	CONNECTION
# 1	INH or No Connection
# 7	Ground
# 8	Output
# 14	Vdc

3. OPTICAL RX YKC22-0733N (DSP: NJ31 NJ32 NJ33)

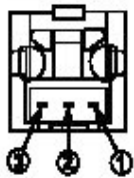

Pin connection

1. GND
2. Vcc
3. Input

Fiber optic connector insertion side

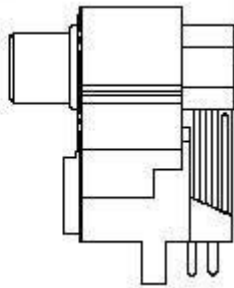
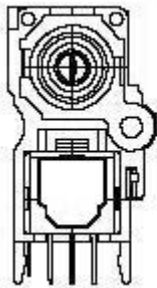
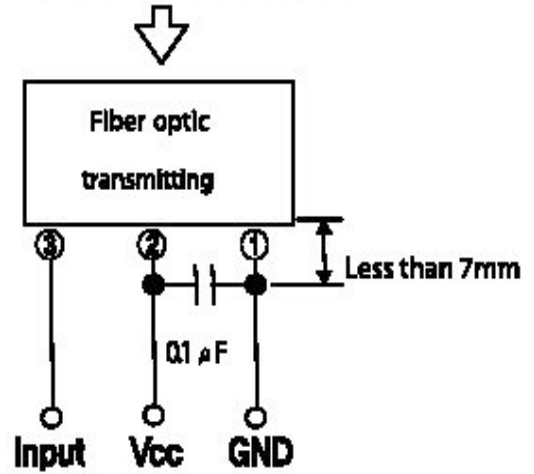

4. TX YKC22-0732N (DSP: NJ34)

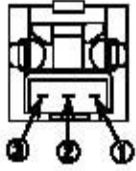

Pin connection

- 1. Output
- 2. GND
- 3. Vcc

Fiber optic connector insertion side

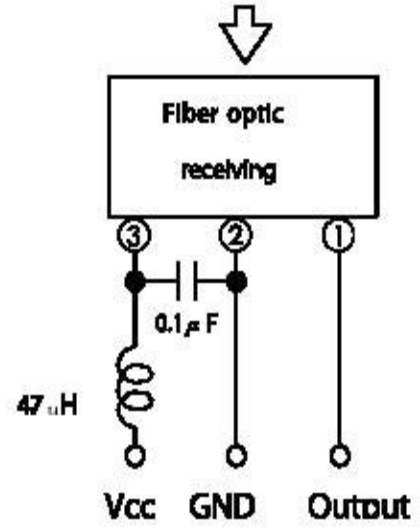

(Bottom View)

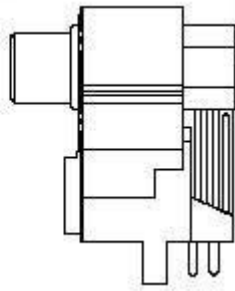
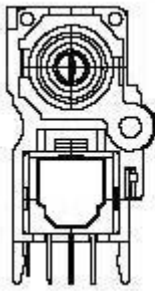

5. TORX177L (FRONT: NJ79)

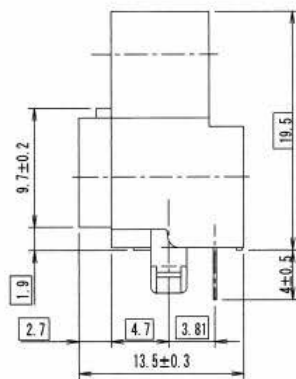
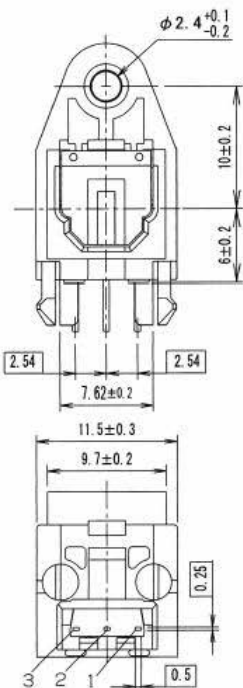

Shutter Color : Black

Pin Connection

- 1. Output
- 2. GND
- 3. Vcc

Fiber optic connector insertion side

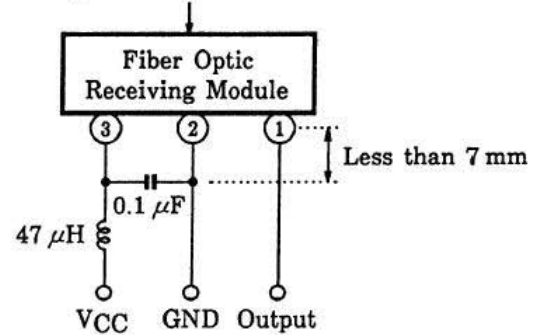

(Bottom View)

2. VCXO 24M576HZ (DSP Y201)

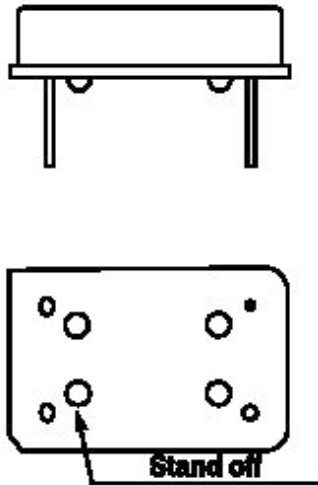

<14 PIN DIP>

PIN	CONNECTION
# 1	INH or No Connection
# 7	Ground
# 8	Output
# 14	Vdc

3. OPTICAL RX YKC22-0733N (DSP: NJ31 NJ32 NJ33)

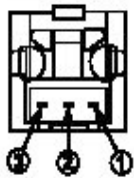

Pin connection

- 1. GND
- 2. Vcc
- 3. Input

Fiber optic connector insertion side

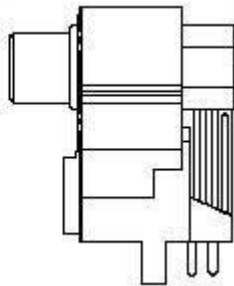
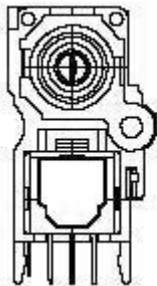
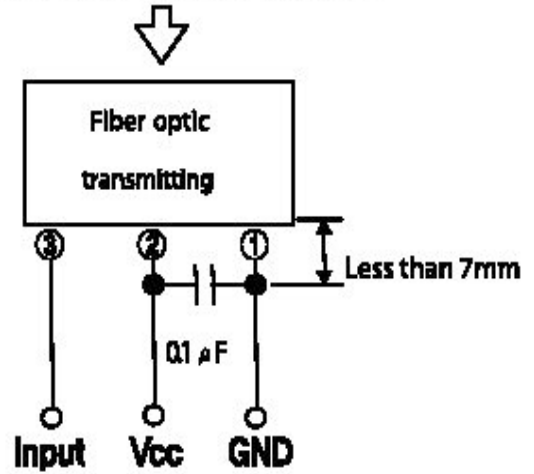

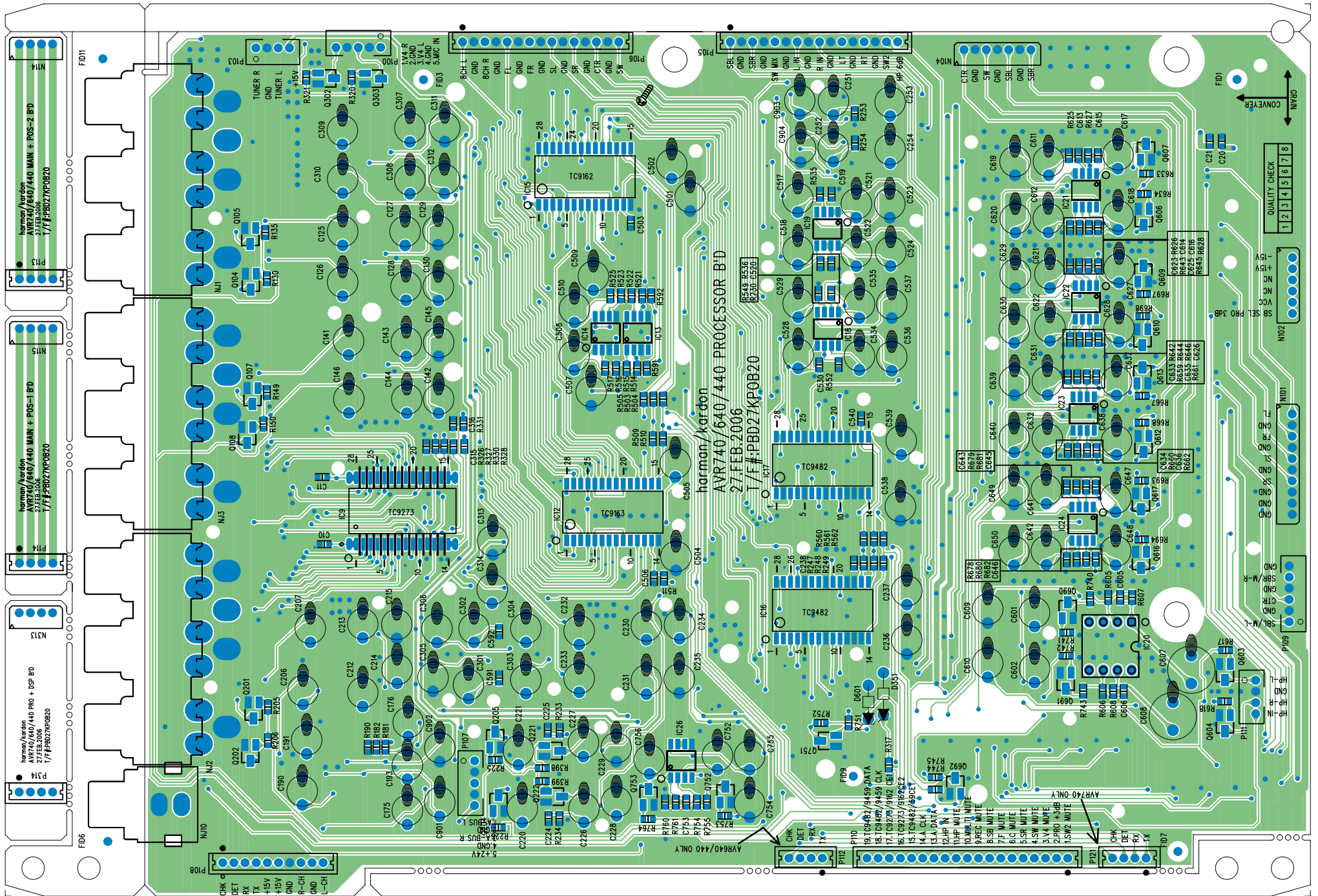

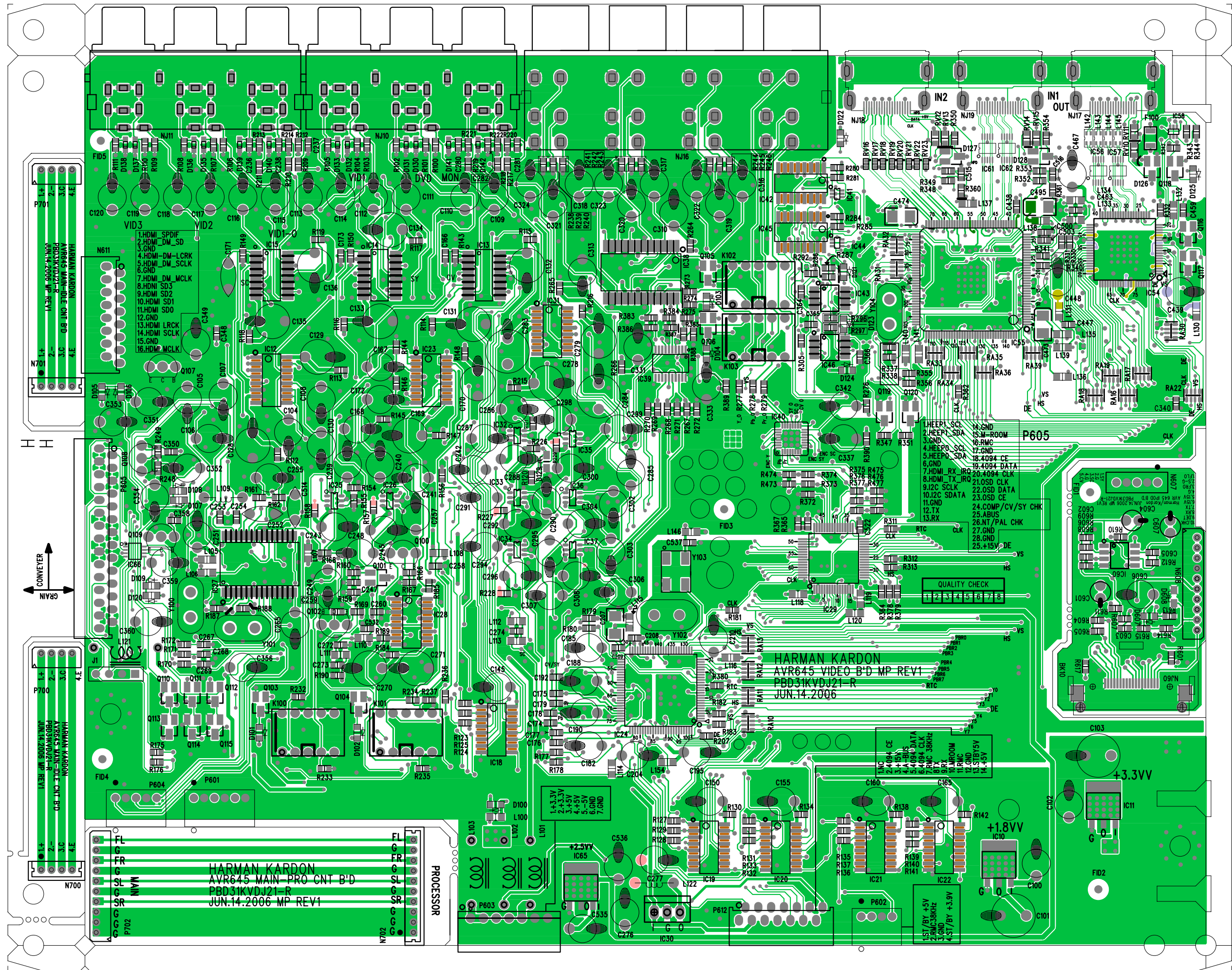

TOP LAYER LAYER COMPOSITION : TOP LAYER

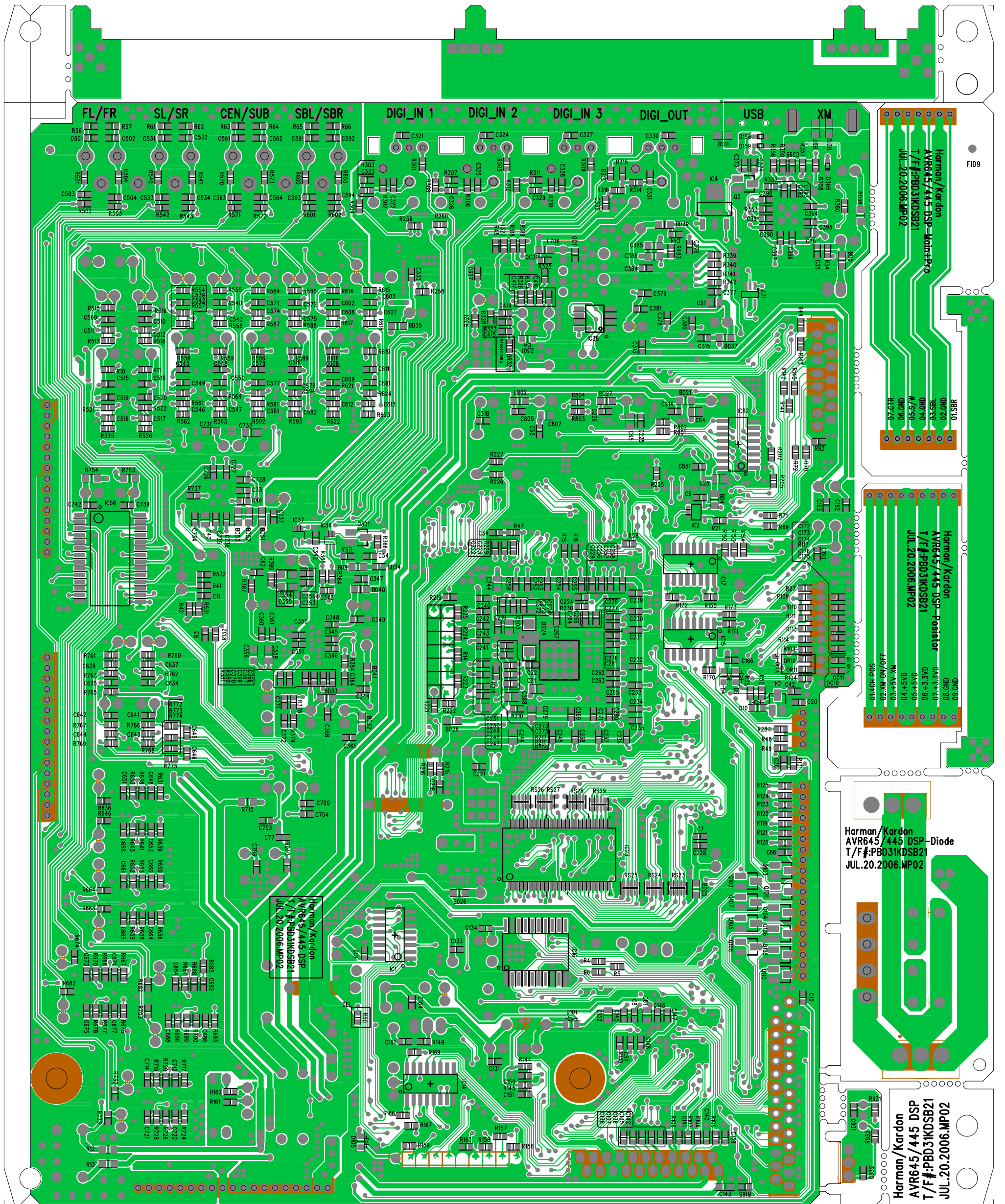

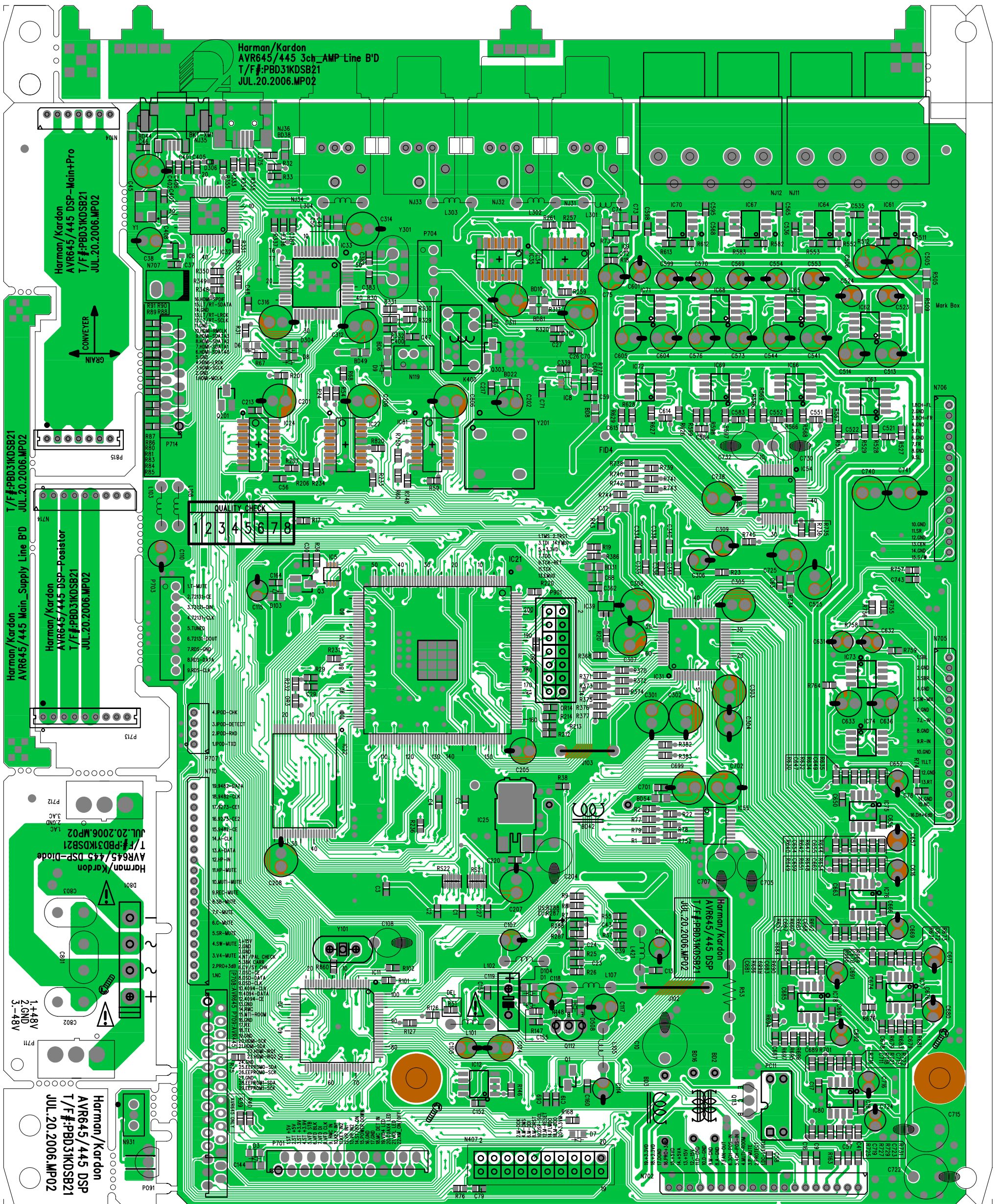

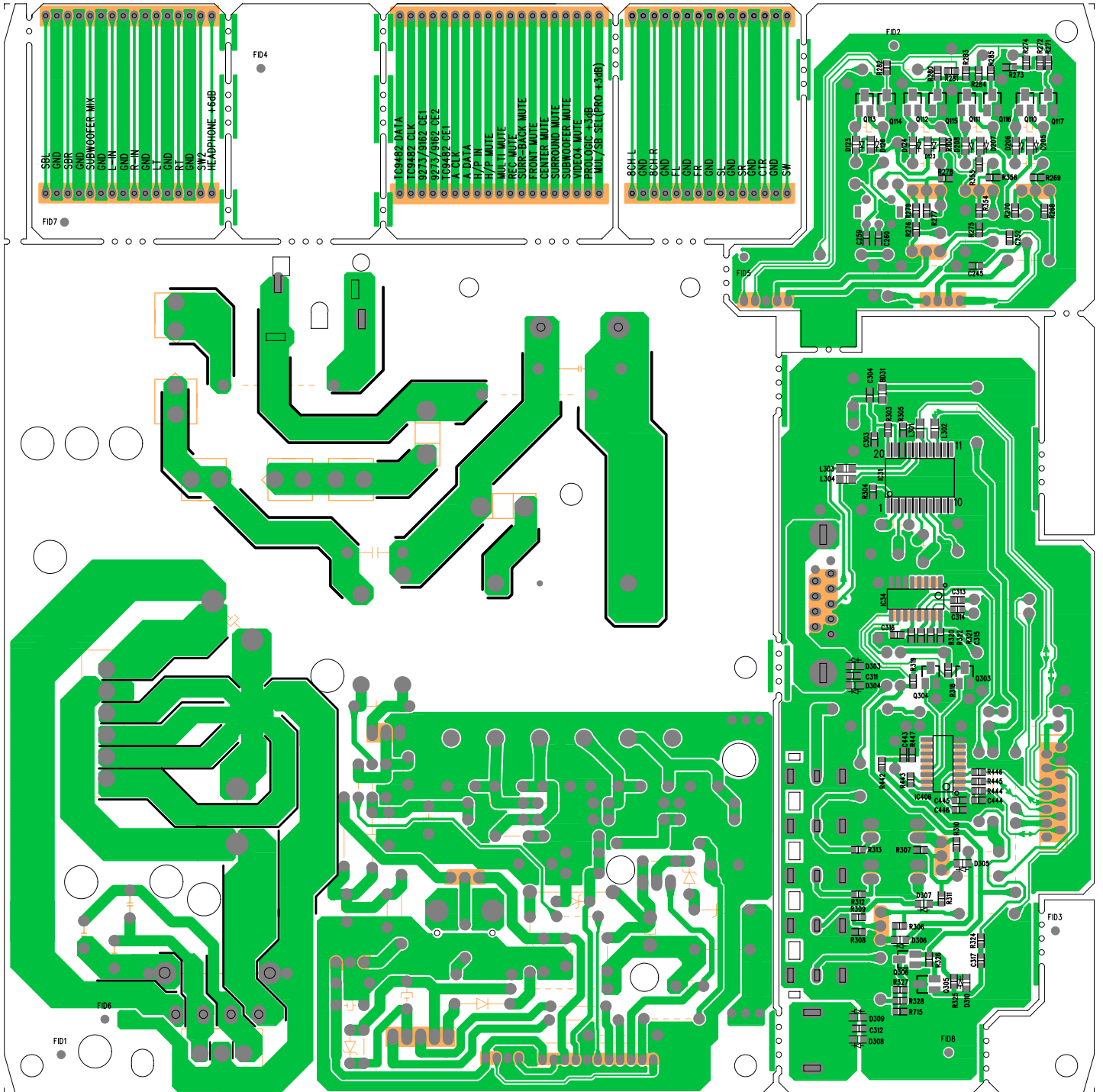

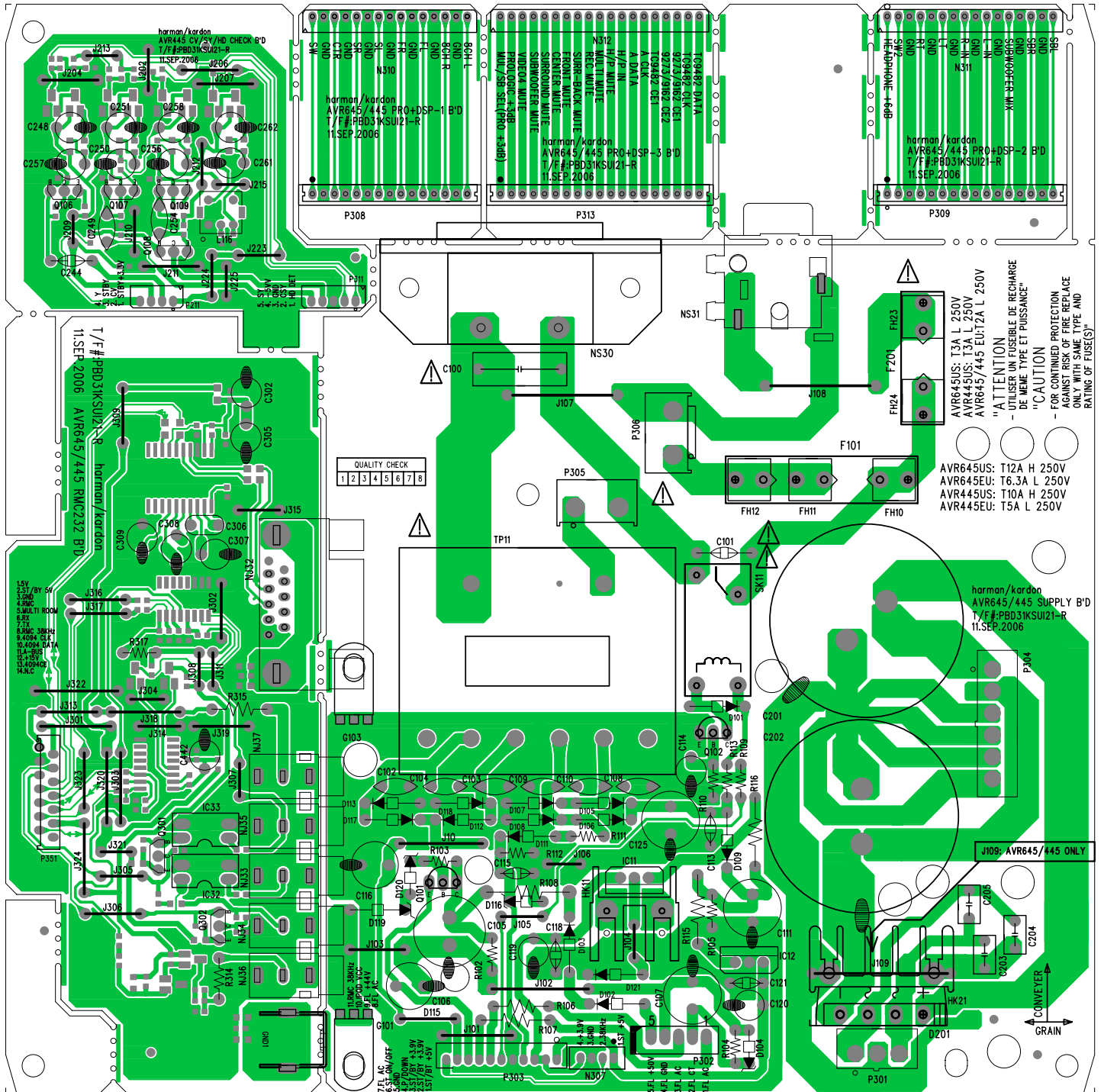

QUALITY CHECK

1	2	3	4	5	6	7	8
---	---	---	---	---	---	---	---

AVR645US: T3A L 250V
 AVR445US: T3A L 250V
 AVR645/445 EU:T2A L 250V
 AVR445US: T10A H 250V
 AVR445EU: T5A L 250V

ATTENTION - UTILISER UN FUSEBLE DE RECHARGE DE MEME TYPE ET PUISSANCE
 "CAUTION - FOR CONTINUED PROTECTION AGAINST RISK OF FIRE REPLACE ONLY WITH SAME TYPE AND RATING OF FUSE(S)"

J109: AVR645/445 ONLY

CONVEYER

GRAIN

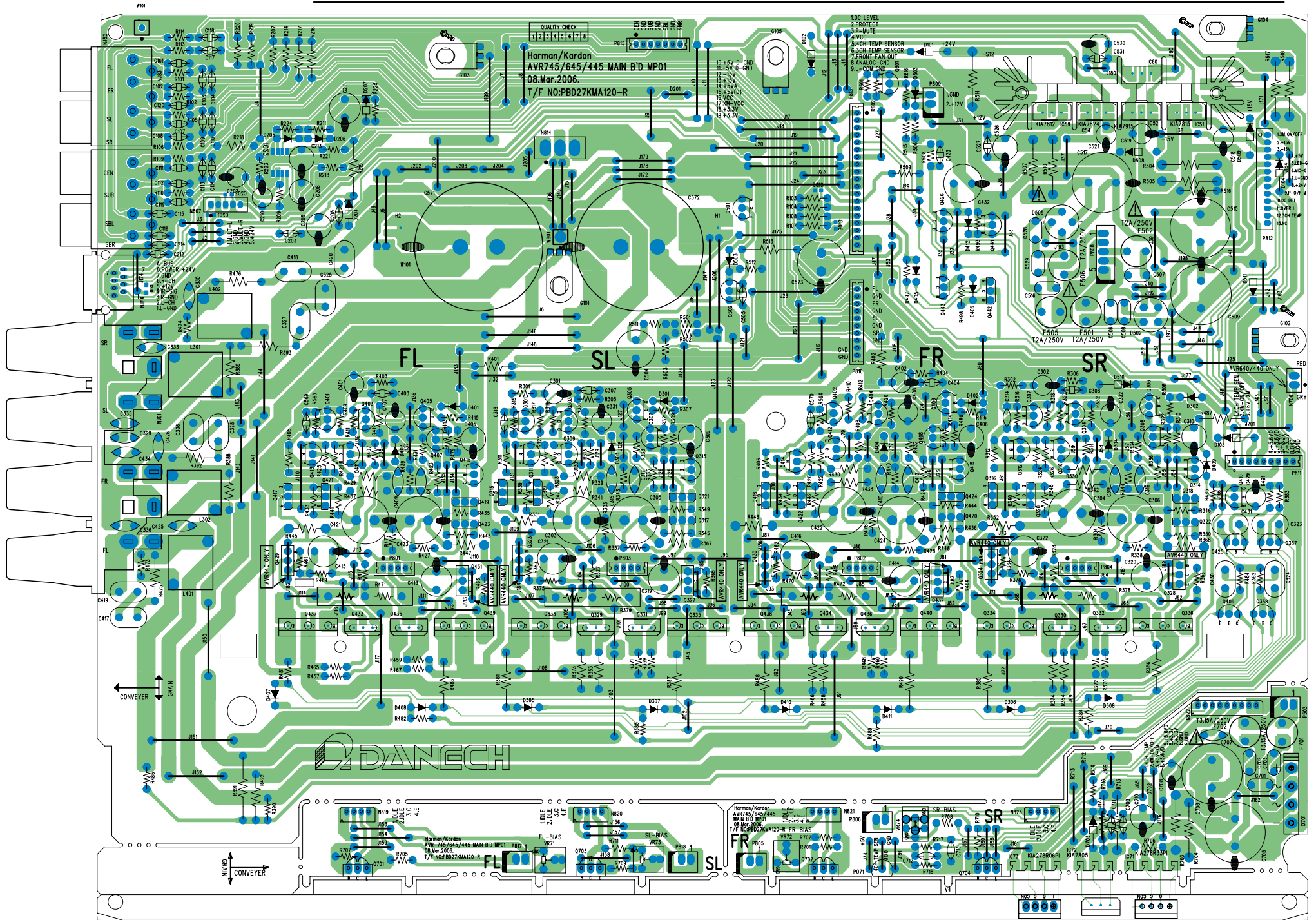

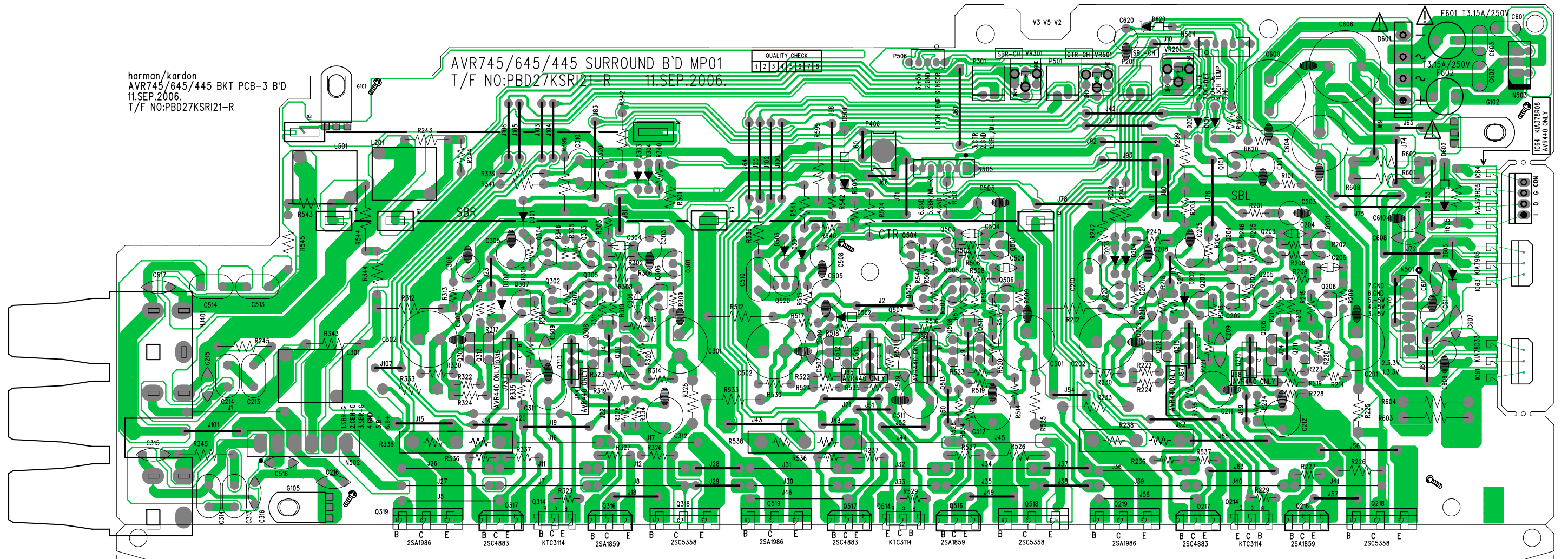

harman/kardon
AVR745/645/445 BKT PCB-3 B'D
11.SEP.2006.
T/F NO: PBD27KSRI21-R

AVR745/645/445 SURROUND B'D MP01
T/F NO: PBD27KSRI21-R 11.SEP.2006.

QUALITY CHECK									
1	2	3	4	5	6	7	8	9	10

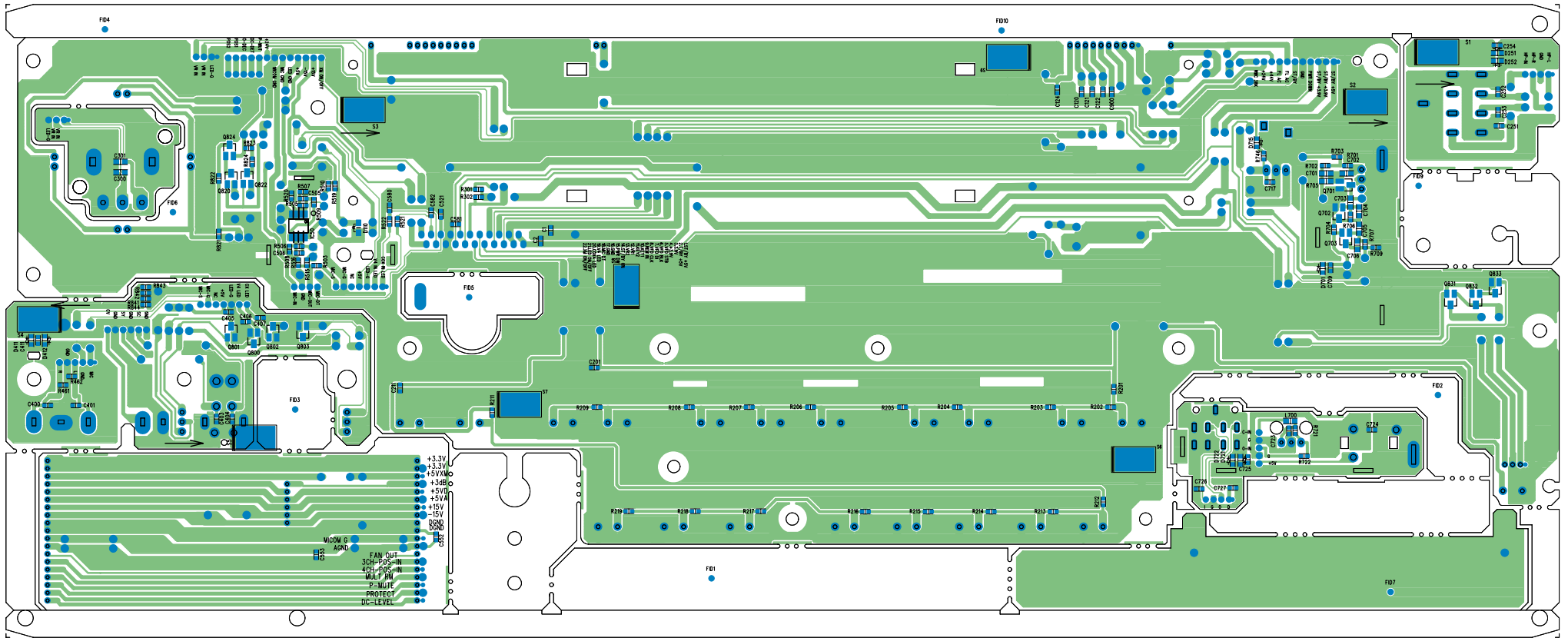

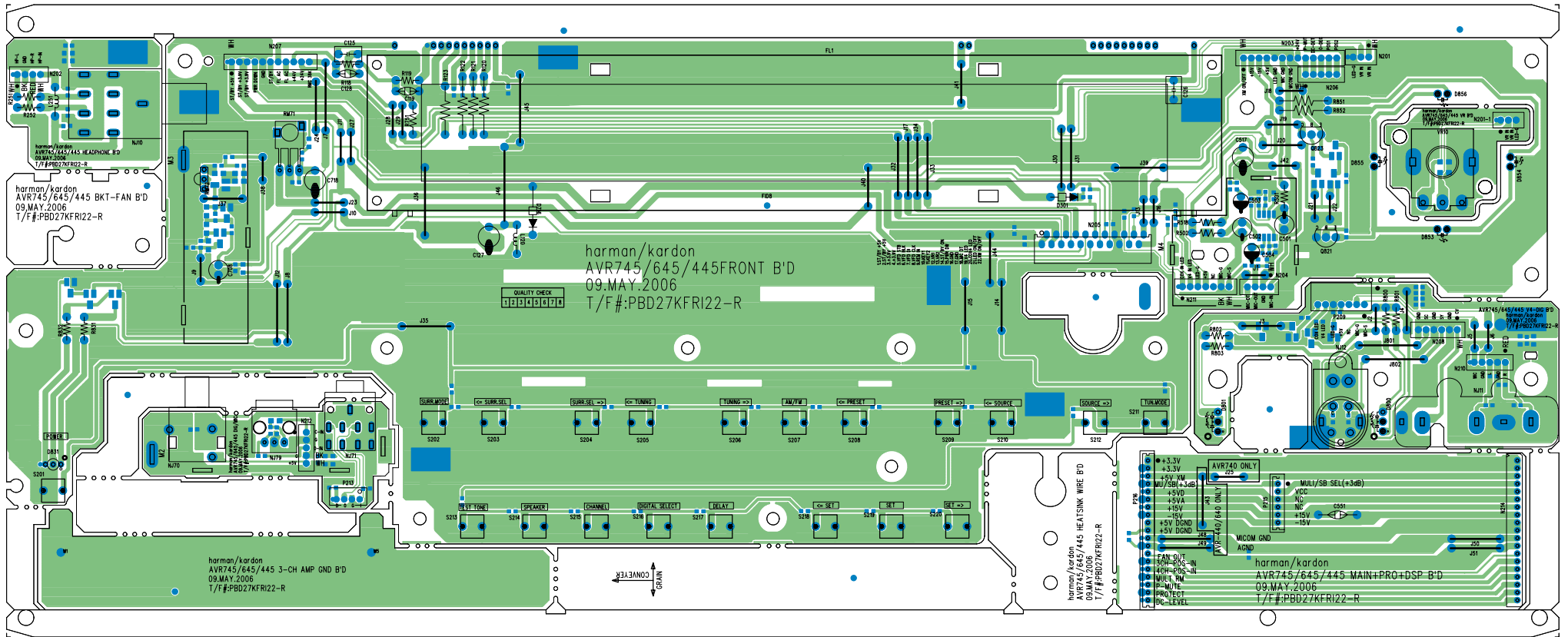

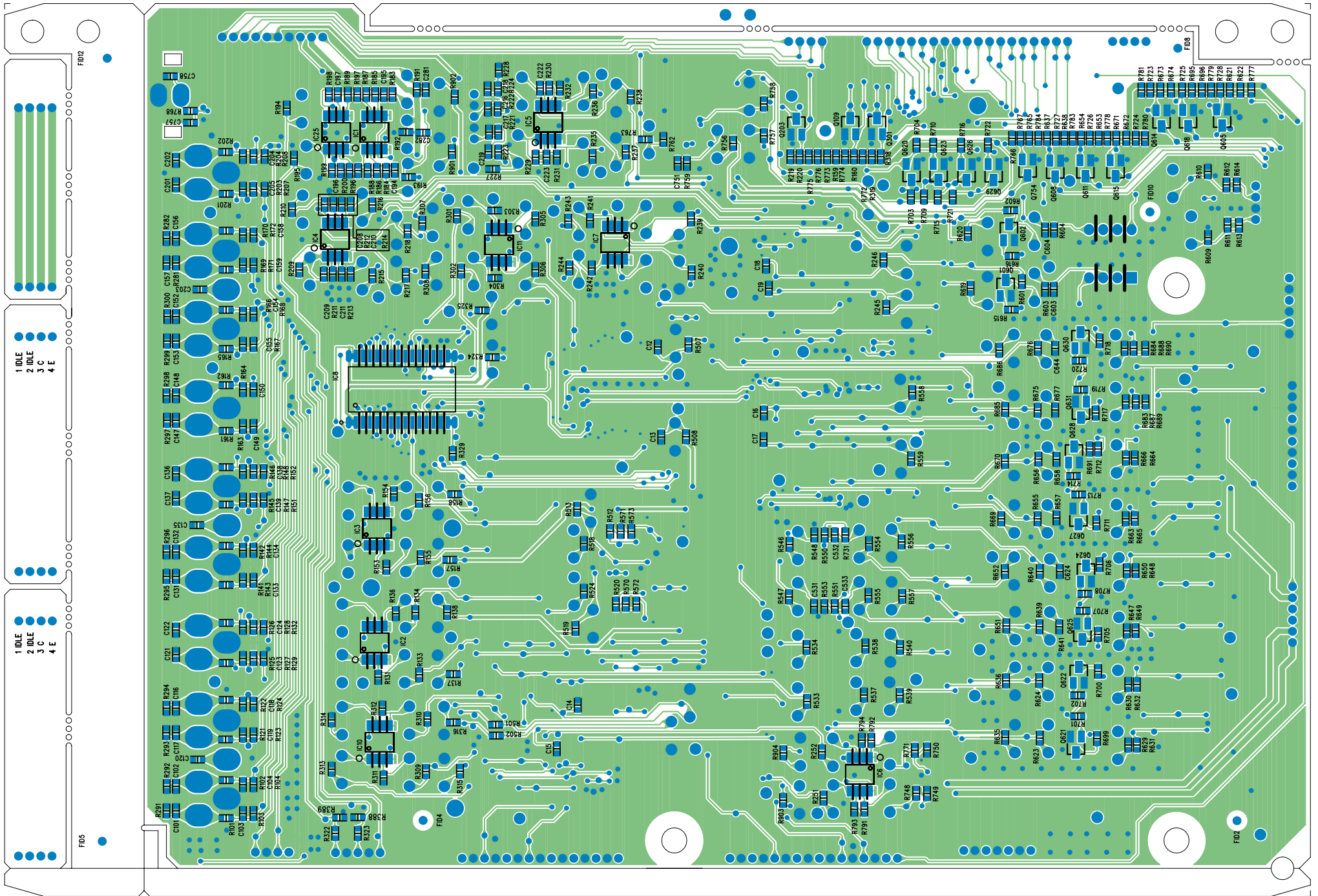

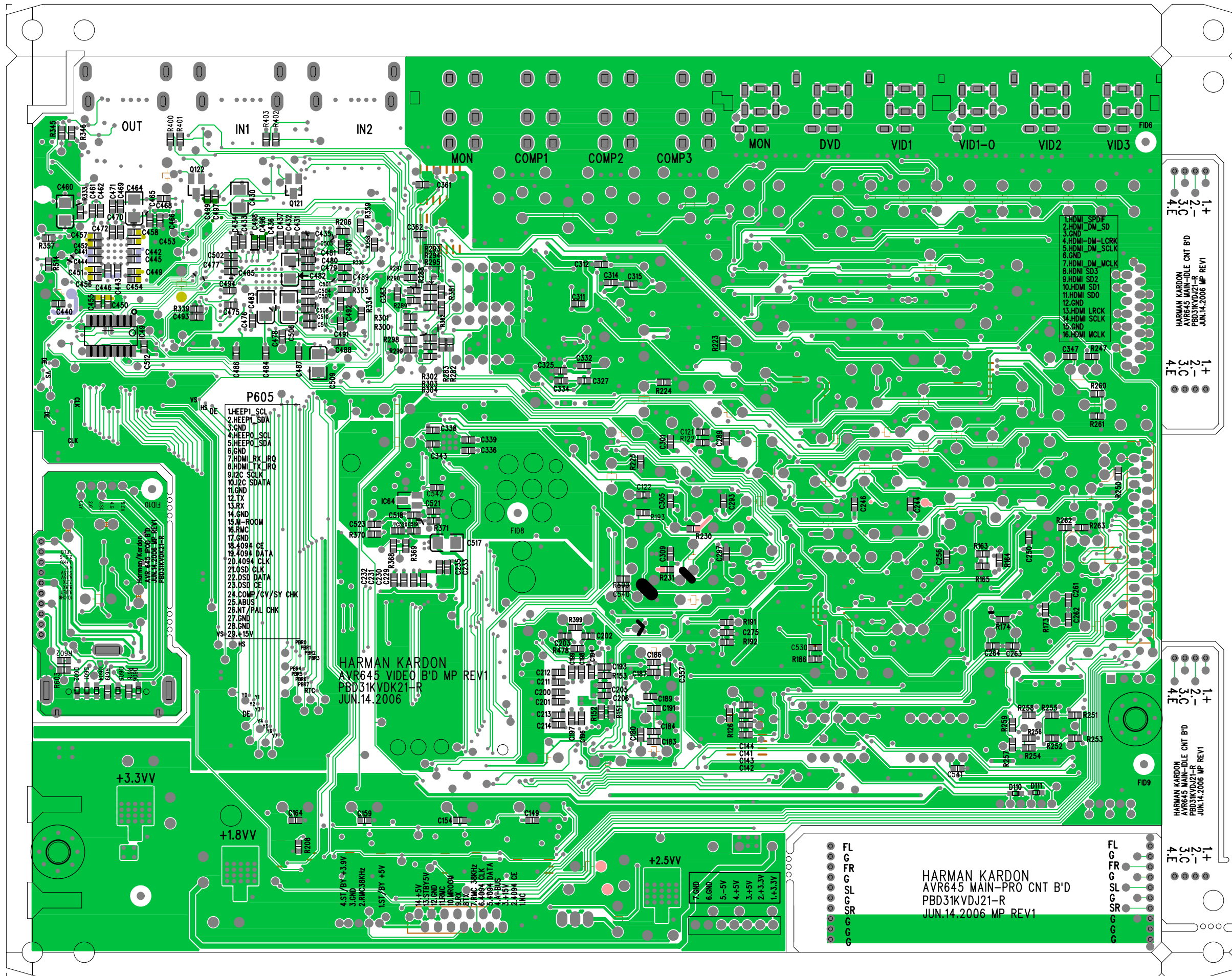

REYAJ MOTTOS
BOTTOM LAYER

REYAJ MOTTOS
BOTTOM LAYER

AVR645 Electrical Parts List			
Ref. Designator	Part Number	Description	
DSP PCB ASS'Y			
<i>Capacitors</i>			
C119	H03-CEZXA0479MN-R	CM 47MIOF +80%-20% 5.5V 70C SCDA5R5473V	
C27	CCKID0470NA-R	CC 47PF +10% -10% 50.0V Y5P	
C26	CCKID0221NA-R	CAPACITOR CERAMIC AXIAL 220PF 50V K Y5P	
C801 C802 C803	CFIOC0104NN-R	CPM 100N0F +10% 250.0V	
C730	H03-CEHEC02275E-R	CE 220UF +20% 10.0V P=5MM 85C SK 220/10V 5 X11	
C204	H03-CEHEC0477MN-R	CE 470U0F +20% 10.0V 85C P=5MM SK 470/10V 6.3 X11	
C14 C105 C107 C114 C115 C118 C306 C309 C523 C524 C553 C554 C569 C570 C599 C601 C616 C617 C631 C632 C652 C657 C669 C680 C691 C692 C716 C724	H03-CEHFC01062S-R	CE 10UF +20% 16V D4XL7 P2.5MM 2000hours 85C	
C45 C201 C206 C207 C208 C301 C302 C303 C305 C307 C308 C310 C311 C312 C314 C316 C505 C506 C525 C699 C702 C725 C738 C740 C741 C806	H03-CEHFC01072S-R	CE 100UF +20% 16V D6.3XL7 P2.5MM 2000hours 85C	
C104 C202 C304 C513 C514 C541 C544 C573 C576 C604 C605 C633 C636	H03-CEHFC04762S-R	CE 47UF +20% 16V D5XL7 P2.5MM 2000hours 85C	
C705 C707 C732	H03-CEHIC01055E-R	CE 1UF +20% 50V D5XL11 P5MM 85C SK 1/50V 5 X11	
C108	CEHIC04755E-R	CE 4U7F +20% 50.0V 85C P5MM	
C10	H03-CEHDC0108NN-R	CE 1000UF +20% 6.3V 8X11.5 85C P5MM	
C722 C715	H03-CEMHC0227AH-R	CAP ELEC 220UF 35V M 8X11.5 SHL SAMYOUNG	
C38 C75 C110 C117 C205	H03-CEMGC04762R-R	CAP ELEC 47UF 25V M 6.3X5 SRE P2.5MM	
C143 C358 C359 C731 C733 C76 C135 C136 C140 C141 C172 C173 C174 C175 C176 C216 C331 C501 C502 C503 C504 C511 C512 C516 C517 C531 C532 C533 C534 C542 C543 C546 C547 C561 C562 C563 C564 C574 C575 C581 C582 C591 C592 C593 C594 C606 C607 C612 C613 C637 C638 C643 C644	CZIKI0104CC-R CZJII0101BE-R	CAP CHIP 100nF 100V X7R 10% 0805 CAP CHIP 100P0F +5% -5% 50.0V NP0 0603	
OC10 OC11	CZJII0101BE-R	CAP CHIP 100P0F +5% -5% 50.0V NP0 0603	EU
C385	CZJII0101CE-R	CAP CERAMIC/CHIP 100PF 50V CH J NPO 0805	
C386	CZJII0102CC-R	CAP CHIP 1nF 50V X7R J 0805	
C322 C325 C328 C416	CZJII0220BE-R	CCCFMIC 22P0F +5% -5% 50.0V NP0	
C33 C34 C150 C151 C223 C224 C364 C371 C372	CZJII0330BE-R	CAP CHIP 33P0F +5% -5% 50.0V NP0 0603	
C139 C142 C373 C374 C714 C721	CZJII0470BE-R CZJII0471BE-R	CAP CHIP 47P0F +5% -5% 50.0V NP0 0603 CCCFMIC 470P0F +5% -5% 50.0V NP0	
C137 C138 C350 C645 C646	CZKII0102BC-R	CAP CHIP 1N0F +10% -10% 50.0V X7R 0603	
C7 C77 C323 C326 C329 C343 C346 C349 C351 C353 C361 C367 C370 C414	CZKII0103BC-R	CAP CHIP 10N0F +10% -10% 50.0V X7R 0603	
C398	CZKII0122BC-R	CAP CHIP 1N2F +10% -10% 50.0V X7R 0603	
C686 C712 C720	CZKII0272BC-R	CAP CHIP 2N7F +10% -10% 50.0V X7R 0603	
C688	CZKII0821BC-R	CAP CHIP 820P0F +10% -10% 50.0V X7R 0603	

Ref. Designator	Part Number	Description	
DSP PCB ASS'Y			
C6 C8 C11 C12 C15 C20 C22 C35 C42 C44 C52 C53 C54 C55 C62 C131 C133 C134 C145 C146 C147 C148 C154 C161 C163 C166 C192 C193 C214 C218 C219 C221 C222 C225 C226 C229 C230 C231 C232 C233 C234 C235 C236 C237 C238 C239 C240 C241 C242 C243 C245 C248 C249 C250 C251 C252 C253 C254 C255 C256 C257 C258 C259 C262 C263 C264 C265 C266 C267 C269 C270 C271 C272 C273 C274 C275 C276 C277 C278 C280 C281 C313 C315 C321 C324 C327 C330 C332 C333 C337 C342 C344 C345 C347 C348 C356 C360 C365 C366 C368 C369 C376 C377 C378 C379 C380 C381 C384 C390 C391 C392 C393 C394 C395 C396 C397 C399 C417 C509 C510 C515 C518 C519 C520 C539 C540 C545 C548 C549 C550 C571 C572 C577 C578 C579 C580 C602 C603 C608 C609 C610 C611 C634 C635 C641 C642 C700 C703 C704 C706 C708 C726 C727 C728 C734 C735 C736 C737 C739 C742 C805 C851 C931	CZZFI0104BF-R	CAP CHIP 100N0F +80% -20% 16.0V Y5V 0603	
C228	CZZFI0224BF-R	CAP CHIP 220NF 16V Y5V +80%-20% 0603	
C21 C25 C36 C40 C51 C61 C64 C65 C132 C203 C244 C246 C247 C268 C279 C807	H03-CTKDE0106FK-R	CAPACITOR MLCC 10UF 6.3V +- 10% C2012X5R0J106K	
C355	CSKIE0102CB-R	CAP,CHIP FORM 1000PF +/-10% 50V 0805 muRata	
C660 C648 C653 C664 C671 C677 C682	CZKII0392BC-R	3n9F 50V X7R K 0603	
C651 C658 C661 C665 C673 C675 C684	CZKII0561BC-R	CAP CHIP 560P0F +10% -10% 50.0V X7R 0603	
C66	CZJII0101BE-R	CAP CHIP 100P0F +5% -5% 50.0V NP0 0603	
C354	CZKII0223CC-R	CAP CHIP 22NF 50V B K X7R 0805	
C415	CZJII0220BE-R	CCCFMIC 22P0F +5% -5% 50.0V NP0	
C382 C383	CSJIE0270BG-R	CAP CHIP FORM,27P,+5%,50V,0603,C0G.	
C407 C408	CSJIE0300BG-R	CAP,CHIP FORM 30P +/-5% 50V C0G 0603	
C23 C24 C743	CZJII0101BE-R	CAP CHIP 100P0F +5% -5% 50.0V NP0 0603	
C29	CZJII0220BE-R	CCCFMIC 22P0F +5% -5% 50.0V NP0	
C713 C723	CZJII0471BE-R	CCCFMIC 470P0F +5% -5% 50.0V NP0	
C43 C521 C522 C551 C552 C583 C584 C614 C615	CZKII0102BC-R	CAP CHIP 1N0F +10% -10% 50.0V X7R 0603	
C37 C50 C70 C338 C339	CZKII0103BC-R	CAP CHIP 10N0F +10% -10% 50.0V X7R 0603	
C387	CZKII0122BC-R	CAP CHIP 1N2F +10% -10% 50.0V X7R 0603	
C687 C711 C719	CZKII0272BC-R	CAP CHIP 2N7F +10% -10% 50.0V X7R 0603	
C689	CZKII0821BC-R	CAP CHIP 820P0F +10% -10% 50.0V X7R 0603	
C9 C13 C16 C17 C18 C19 C30 C39 C41 C46 C47 C48 C56 C57 C58 C59 C60 C63 C67 C69 C71 C78 C79 C152 C153 C155 C160 C164 C213 C217 C220 C362 C375 C400 C405 C406 C535 C536 C565 C568 C595 C598 C650 C656 C663 C666 C674 C676 C685 C690 C701	CZZFI0104BF-R	CAP CHIP 100N0F +80% -20% 16.0V Y5V 0603	
C1 C2 C3 C4 C5 C227	CZZFI0224BF-R	CAP CHIP 220NF 16V Y5V +80%-20% 0603	

Ref. Designator	Part Number	Description	
DSP PCB ASS'Y			
C49 C68	H03-CTKDE0106FK-R	CAPACITOR MLCC 10UF 6.3V +- 10% C2012X5R0J106K	
C647 C654 C659 C667 C670 C678 C681	CZKII0392BC-R	3n9F 50V X7R K 0603	
C649 C655 C662 C668 C672 C679 C683	CZKII0561BC-R	CAP CHIP 560P0F +10% -10% 50.0V X7R 0603	
C144	CZIKI0104CC-R	CAP CHIP 100nF 100V X7R 10% 0805	
C32	RS3BB0100NA-R	RES,CHIP,10OHM 1/10W +/-5%,0805	
<i>Semiconductors</i>			
Q113	H03-TRKTA107MNA-R	TR-SLPSWA KRA107M PNP	
Q112	H03-TRMPSA06NNA-R	TR-SLPLF MPSA06 N 500MIOA TO-92 NPN	
D801	H03-DURS10040NA-R	RS1004 RS-10	
D158 D159	H03-DS05GBUSCNB-R	DIODE PG05GBUSC	
D305	H03-DS05GBUSCNB-R	DIODE PG05GBUSC	US
D4 D5 D10 D101 D301	H03-DS1S50094NB-R	D-SLP 1SS355 35.0V 225MIOA	
IC38	H03-IC24LC64ID2-R	24LC64-I/SNG SOIC-8P(150mil) 64K I2C Serial EEPROM	
IC7	H03-IC74AHC1G14-R	74AHC1G14 SOT753 Inverting Schmitt trigger	
IC2	H03-IC74LC1G1DL-R	IC SINGLE SCHMITT BUFFER SN74LVC1G17DBVR SOT(SOT-23)DBV	
IC82	H03-IC74LVC254D-R	IC SN74LVC257AD SOIC-16 Quadruple 2-Line To 1-Line Data Selector/Multiplexer With 3-State Outputs	
IC16	H03-IC74VC244G5-R	IC-LOGIC 74VHC244MX or 74VHC244MX_NL M20B Octal Buffer/Line Driver with 3-STATE Outputs	
IC1	H03-ICBU4051BD3-R	8-channel analog multiplexer /demultiplexer BU4051BCF SOP16	
IC14 IC15 IC17	H03-ICBU4094BD3-R	IC CMOS BU4094BCF SOP16 8-bit compatible shift / store register	
IC4	H03-ICDS1233ADK-R	IC 3.3V ECONO RESET DS1233AZ-15+TR SOT-223	
IC23	H03-ICK4S1616UC-R	K4S161622H-UC60 OR UC80 TSOP50 SDRAM	
IC56	H03-ICTC9162CDA-R	IC CMOS DIGITAL TC9162CFG SOP28 HIGH VOLTAGE ANALOG FUNCTION SWITCH ARRAY	
Q2 Q4 Q101 Q102 Q103 Q104 Q105 Q106 Q107 Q108 Q109 Q110 Q301	H03-TSKRC107SND-R	KRC107S SOT-23 NPN	
IC36 IC37	H03-ICC1G125DCK-R	IC SINGLE BUS BUFFER GATE SN74LVC1G125DCKT SOT(SC-70)DCKT	
IC12	H03-IC24LC256D2-R	IC CMOS SERIAL EEPROM 24LC256T-I/SNG SOIC-8P(150MIL)	
IC11	H03-IC70F3261E1-R	UPD70F3261YGC-8EA-A LQFP100 100-pin general-purpose 32-bit single-chip microcontroller	
IC5	H03-IC74CB3T3D2-R	IC SN74CB3T3306DCTR SSOP-8 Dual Bus Switch Voltage Translator	
IC39	H03-IC74LC1G1DL-R	IC SINGLE SCHMITT BUFFER SN74LVC1G17DBVR SOT(SOT-23)DBV	
IC24 IC27 IC81	H03-IC74LVC254D-R	IC SN74LVC257AD SOIC-16 Quadruple 2-Line To 1-Line Data Selector/Multiplexer With 3-State Outputs	
IC31	H03-ICCS42528E6-R	IC CS42528-CQZ-D QFP64 114 dB, 192 kHz 8-Ch Codec with S/PDIF Receiver	
IC54	H03-ICCS5368BE8-R	CS5368-CQZ LQFP48 REV. B0 114 dB, 192 kHz Multichannel A/D Converters	
IC61 IC62 IC63 IC64 IC65 IC66 IC67 IC68 IC69 IC70 IC71 IC72 IC73 IC74 IC75 IC76 IC77 IC78 IC80	H03-ICLM02068D2-R	IC-OPERAMP NJM2068M-TE1 DUAL OP-AMP SOP8	
IC25	H03-ICM317T0252-R	IC 3-TERMINAL ADJUSTABLE POS VOL REG NJM317DL1-TE1 TO-252	
IC6	H03-ICNJM2872D0-R	NJM2872AF33-TE1 3.3V SOT-23(MPT5) LOW DROPOUT VOLTAGE REGULATOR	US
IC55	H03-ICS4391AKZZ-R	CS4391A-KZZ SOP20 24-BIT, 192 kHz STEREO DAC WITH VOLUME CONTROL	
IC34 IC35	H03-ICSN74HCU04-R	IC SN74HCU04D HEX INVERTER	
IC21	H03-ICTMS320DA6-R	IC FLOATING-POINT DSP TMS320D610A PQFP208	
IC33	H03-ICTUSB320EB-R	ICTUSB3200A TQFP52 USB Streaming Controller (STC)	
IC32	H03-ICXMDIC00E8-R	IC DIGITAL TRANCEIVER XMDIC QFP48	US
D306	H03-DS05GBUSCNB-R	DIODE PG05GBUSC	US
D1 D3 D6 D7 D8 D9 D103 D104 D304 D508	H03-DS1S50094NB-R	D-SLP 1SS355 35.0V 225MIOA	
Q1 Q3 Q201 Q303	H03-TSKRC107SND-R	KRC107S SOT-23 NPN	
IC22	H03-ICM29W160ET-R	IC FLASH MEMORY M29W160ET TSOP48 ST	

Ref. Designator	Part Number	Description	
DSP PCB ASS'Y			
IC8	H03-ICC1G125DCK-R	IC SINGLE BUS BUFFER GATE SN74LVC1G125DCKT SOT(SC-70)DCKT	
<i>Resistors</i>			
RS23 RS24 RS25 RS26 RS27 RS28 RS29	RN3AY0220NA-R	RES NETWORK RCA 22OHM 1/16W 5% CN34JT220	
R21	RS1AD0100NA-R	RES CHIP 10 OHM 1/16W 1% 0603	
R483	RS1AD3091NA-R	RES CHIP 3.09K OHM 1/16W 1% 0603	
R44	RS3AD0000NA-R	RES CHIP, 0 R 1/16W +/-5%, 0603	
R103 R104	RS3AD0000NA-R	RES CHIP, 0 R 1/16W +/-5%, 0603	US
R48 R49 R69 R70 R71 R72 R119 R120 R121 R122 R123 R124 R125 R143 R202 R205 R235 R301 R305 R309 R314 R801 R802 R803 R804	RS3AD0100NA-R	RMGCFMIC 10R0 OHM +5% 0603	
R10 R11 R132 R226 R227 R313 R357 R358 R364 R365 R556 R559 R586 R589 R616 R619 R765 R932	RS3AD0101NA-R	RES CHIP,100R 1/16W +/-5%,0603	
R113 R114 R216 R304 R308 R312 R356 R359	RS3AD0102NA-R	RES CHIP,1K 1/16W +/-5% ,0603	
OR10 OR11	RS3AD0102NA-R	RES CHIP,1K 1/16W +/-5% ,0603	EU
R35 R52 R131 R149 R215 R517 R518 R521 R522 R525 R526 R557 R558 R561 R562 R563 R564 R587 R588 R591 R592 R593 R594 R617 R618 R621 R622 R623 R624 R737 R762 R763 R766 R767 R768 R769	RS3AD0103NA-R	RES CHIP,10K 1/16W +/-5% ,0603	
R34 R155 R165 R169 R170 R303 R307 R311 R328 R352 R353 R502 R503 R542 R543 R571 R601 R602 R636 R646 R663 R664 R674 R682 R692 R703 R732 R733	RS3AD0104NA-R	RES CHIP,100K 1/16W +/-5% ,0603	
R319 R633 R643 R652 R659 R670 R678 R687 R698	RS3AD0122NA-R	RMGCFMIC 1K2 OHM +5% 0603	
R256 R258 R260	RS3AD0152NA-R	RES CHIP 1K5 1/16W +5% 0603	
R15 R16 R117 R219 R318	RS3AD0153NA-R	RES CHIP,15K 1/16W,+/-5%,0603.	
R210 R218	RS3AD0182NA-R	RES CHIP,1.8K,1/16W,+5%,0603.	
R699	RS3AD0183NA-R	RMGCFMIC 18K0 OHM +5% 0603	
R719 R728	RS3AD0202NA-R	RMGCFMIC 2K0 OHM +5% 0603	
R515 R516 R554 R555 R584 R585 R614 R615 R760 R761	RS3AD0203NA-R	RMGCFMIC 20K0 OHM +5% 62M15W 0603	
R6 R105 R106 R107 R108	RS3AD0221NA-R	RMGCFMIC 220R0 OHM +5% 0603	
R27 R144 R145 R378 R379	RS3AD0222NA-R	RMGCFMIC 2K2 OHM +5% 0603	
BD34 R321	RS3AD022ANA-R	RMGCFMIC 2R2 OHM +5% 0603	
R316 R326	RS3AD0241NA-R	RES CHIP 240 OHM 1/16W +/-5% 0603	
R772 R773 R774 R775	RS3AD0331NA-R	RMGCFMIC 330R0 OHM +5% 0603	
R573	RS3AD0332NA-R	RMGCFMIC 3K3 OHM +5% 0603	
R387	RS3AD033ANA-R	RMGCFMIC 3R3 OHM +5% 0603	
R162 R209 R211 R217 R229 R230	RS3AD0392NA-R	RMGCFMIC 3K9 OHM +5% 0603	
R717 R724	RS3AD0432NA-R	RMGCFMIC 4K3 OHM +5% 0603	
R4 R5 R152 R153 R154 R166 R167 R171 R172 R173 R931	RS3AD0471NA-R	RMGCFMIC 470R0 OHM +5% 0603	
R28 R109 R110 R111 R161 R339 R340 R341 R342 R366 R531 R532 R631 R639 R650 R656 R677 R675 R685 R693 R720 R726	RS3AD0472NA-R	RES CHIP,4K7 1/16W +/-5%,0603	
R3 R130 R380 R381	RS3AD0473NA-R	RES CHIP,47K 1/16W +/-5%,0603	
R41 R42	RS3AD0474NA-R	RMGCFMIC 470K0 OHM +5% 0603	
R324	RS3AD047ANA-R	RES CHIP,4R7 1/16W +/-5%,0603.	

Ref. Designator	Part Number	Description	
DSP PCB ASS'Y			
R638 R641 R653 R658 R668 R667 R688	RS3AD0562NA-R	RMGCFMIC 5K6 OHM +5% 0603	
R327 R700	RS3AD0681NA-R	RES CHIP,680R 1/16W +/-5%,0603	
R572	RS3AD0682NA-R	RMGCFMIC 6K8 OHM +5% 0603	
R46 R47 R302 R306 R310 R315 R325 R323 R384	RS3AD0750NA-R	RMGCFMIC 75R0 OHM +5% 0603	
R501 R504 R540 R541 R570 R600 R603	RS3AD0821NA-R	RMGCFMIC 820R0 OHM +5% 0603	
R56 R57 R61 R62 R63 R64 R65 R66	RS3AD0823NA-R	RES,CHIP 82K,1/16W,+/-5%,0603	
R12 R13 R753 R754	RS3BB0101NA-R	RES,CHIP,100 OHM 1/10W +/-5%., 0805	
R360	RS3AD0105NA-R	RES CHIP 1M 1/16W +5% 0603	
R389	RS1AD1371NA-R	RES.CHIP,1.37K OHM ,1/16W,+/-1%,0603	
R715	RS3BB0150NA-R	RES,CHIP,15 OHM 1/10W +/-5% 0805	
BD7 BD11 BD12	RS3BB0000NA-R	RES CHIP 0 OHM +5% 100MIOW 0805	
R140 R141 R142	RS3AD0220NA-R	RES CHIP,22R 1/16W +/-5%,0603	
R58	RS3AD0470NA-R	RMGCFMIC 47R0 OHM +5% 0603	
R45	RS3AD0124NA-R	RES CHIP,120K 1/16W +/-5%,0603	
RS21 RS22	RN3AY0220NA-R	RES NETWORK RCA 22OHM 1/16W 5% CN34JT220	
R17 R20 R738 R739 R750 C340	RS1AD0100NA-R	RES CHIP 10 OHM 1/16W 1% 0603	
R32	RS1AD3321NA-R	RES CHIP 3.32K OHM 1/16W 1% 0603	
R33	RS1AD4751NA-R	RES.CHIP 4.75K 1/16W +/-1% 0603	
R126 R127 R317 R320 C341 C334 C335 C336	RS3AD0000NA-R	RES CHIP, 0 R 1/16W +/-5%, 0603	
R24 R54 R68 R206 R207 R233 R234 R331 R332 R748 R820	RS3AD0100NA-R	RMGCFMIC 10R0 OHM +5% 0603	
R2 R30 R74 R382 R383 R745 R764	RS3AD0101NA-R	RES CHIP,100R 1/16W +/-5%,0603	
R7 R8 R9 R31 R354 R755 R756 R757 R860	RS3AD0102NA-R	RES CHIP,1K 1/16W +/-5% ,0603	
R25 R26 R36 R39 R40 R101 R236 R735 R736	RS3AD0103NA-R	RES CHIP,10K 1/16W +/-5% ,0603	
R288	RS3AD0103NA-R	RES CHIP,10K 1/16W +/-5% ,0603	US
R287	RS3AD0103NA-R	RES CHIP,10K 1/16W +/-5% ,0603	EU
R29 R38 R43 R147 R348 R349 R350 R351 R355	RS3AD0104NA-R	RES CHIP,100K 1/16W +/-5% ,0603	
R632 R642 R651 R660 R669 R679 R686 R697	RS3AD0122NA-R	RMGCFMIC 1K2 OHM +5% 0603	
R333	RS3AD0152NA-R	RES CHIP 1K5 1/16W +5% 0603	
R257 R259 R261	RS3AD0153NA-R	RES CHIP,15K 1/16W,+/-5%,0603.	
OR14 R212 R213 R214	RS3AD0182NA-R	RES CHIP,1.8K,1/16W,+5%,0603.	
R696	RS3AD0183NA-R	RMGCFMIC 18K0 OHM +5% 0603	
R718 R727	RS3AD0202NA-R	RMGCFMIC 2K0 OHM +5% 0603	
R79	RS3AD0220NA-R	RES CHIP,22R 1/16W +/-5%,0603	
R334 R335	RS3AD0270NA-R	RES,CHIP 27 OHM 1/16W +/-5% 0603	
R527 R528 R529 R530 R566 R567 R568 R569 R596 R597 R598 R599 R626 R627 R628 R629	RS3AD0331NA-R	RMGCFMIC 330R0 OHM +5% 0603	
R220	RS3AD0392NA-R	RMGCFMIC 3K9 OHM +5% 0603	
R716 R725	RS3AD0432NA-R	RMGCFMIC 4K3 OHM +5% 0603	
R163 R168	RS3AD0471NA-R	RMGCFMIC 470R0 OHM +5% 0603	
R67 R146 R148 R201 R232 R329 R330 R336 R337 R630 R640 R649 R657 R666 R676 R684 R694 R721 R729	RS3AD0472NA-R	RES CHIP,4K7 1/16W +/-5%,0603	
R102 R511 R512 R552 R553 R582 R583 R612 R613 R758 R759	RS3AD0473NA-R	RES CHIP,47K 1/16W +/-5%,0603	
R37	RS3AD0474NA-R	RMGCFMIC 470K0 OHM +5% 0603	
R635 R644 R654 R662 R673 R681 R690 R701 R722 R731	RS3AD0561NA-R	RES CHIP,560R 1/16W +/-5%,0603	
R634 R647 R648 R661 R671 R683 R689	RS3AD0562NA-R	RMGCFMIC 5K6 OHM +5% 0603	

Ref. Designator	Part Number	Description	
DSP PCB ASS'Y			
R695	RS3AD0681NA-R	RES CHIP,680R 1/16W +/-5%,0603	
R73 BD38 BD44	RS3BB0000NA-R	RES CHIP 0 OHM +5% 100MIOW 0805	
R505 R509	RS3BB0101NA-R	RES,CHIP,100 OHM 1/10W +/-5%., 0805	
R19 R22 R59 R60 R75 R76 R77 R78 R368 R370 R371 R372 R373 R374 R375 R376 R377 R386 R740 R741 R742 R743 R744	RS3AD0470NA-R	RMGCFMIC 47R0 OHM +5% 0603	
R734	RS1BB022ANA-R	RES.CHIP,2.2 OHM ,1/16W,+/-1%,0805	
R777	RS3AD010ANA-R	RES CHIP,1R 1/16W +/-5%,0603	
R1 R752	RS3AD0221NA-R	RMGCFMIC 220R0 OHM +5% 0603	
R23	RS3AD0390NA-R	RES,CHIP 39 OHM 1/16W +/-5% 0603	
R231	RS3AD0750NA-R	RMGCFMIC 75R0 OHM +5% 0603	
R53	RC3DI010AIN-R	RCF 1R0 OHM +5% 250MIOW	
<i>Miscellaneous</i>			
BD4 BD9 BD21 BD25 BD26 BD27 BD28 BD32 BD33 BD35 BD37 BD39 BD40 BD41 BD51 BD52 BD53 L706 L802	H03-FB3012012CF-R	FCM2012CF-301T04 0805	
BD5 BD36	H03-FB3012012CF-R	FCM2012CF-301T04 0805	US
BD24	H03-FYACF333TNN-R	FILTER ACF451832-333-T	
BD81	H03-FB2522012HF-R	FCM2012HF-252T02 2500ohm SURFACE MT 2012	
BD6 BD8 BD10 BD22 BD31 BD49 BD54	H03-FB3012012CF-R	FCM2012CF-301T04 0805	
Y1	H03-OSXNL4515B0-R	CRYSTAL 45.1584MHz 22p SO22320D5-45.1584-T&R	US
NJ36	H03-SOUSB5005K0-R	AU6-EC-005K0	
NJ35	H03-SOUSB45810B-R	JACK R41-5810B (Mitsumi) XM/DT connector	US
P091	H03-ICLM19CIZIE-R	IC TEMPERATURE SENSOR LM19CIZ 2.4V TO-92	
PC11	H03-ICPC17T10B1-R	IC PHOTOCOUPLER PC-17T1 DIP4 KODENSHI	
Y101	H03-OSCEM05M0RU-R	CERAMIC RESONATOR CSTLS_G 5.0MHz	
Y201	H03-OSCEM24M5RU-R	VCXO 24M576 HZ +50 PPM -50 PPM 0 OHM 3.3V	
Y301	H03-OSX06M0HZ00-R	CRYSTAL 6MHz 2P WOOIN HC-49/S 22PF	
K400	H03-RLL0516632B-R	RELAYPWR 5.0V 166.0OHM 1.0A 24.0V	
NJ12	H03-SORA40RSANN-R	JACK RCA 4P JB040131ZN GN BN PP TA	
NJ11	H03-SORA40RSCNN-R	JACK RCA 4P JB040131QN WH BU RD GY	
NJ31 NJ32 NJ33	H03-SORX220751N-R	YKC22-0751N	
NJ34	H03-SOTX220750N-R	YKC22-0750N	
N931	H03-WE03B012000-R	WIRE ASS'Y UL1007#26 120MM 2.0MM 3P WHT	
N707	H03-WN02SD00000-R	CONN 2.5MM 2 MA ST NAT 5267-02A 0 0	US
P711 P712	H03-WN03SE00000-R	CON 3.96MM PITCH MOLEX 35313-0310	
P707	H03-WN04AB100WH-R	CONN WAFER 2.0MM 4P 35237-0410 WHT	
P704	H03-WN05SB00000-R	CONNECT 2.0mm 5P GIL-S-5P-S2T2-EF	
N104	H03-WN07AB100WH-R	CONN WAFER 2.0MM 7P 35237-0710 WHT	
P815	H03-WN07SB100WH-R	CONN WAFER 2.0MM 7P 35336-0710 WHT	
N714	H03-WN09AB100WH-R	CONNECT WAFER 2.0mm 9P 35237-0910 WHT	
P703	H03-WN09SB00000-R	CONNECT 2.0mm 9P GIL-S-9P-S2T2-EF	
P713	H03-WN09SB100WH-R	CONNECT WAFER 2.0mm 9P 35336-0910 WHT	
N706	H03-WN15AB100WH-R	CONNECT WAFER 2.0mm 15P 35237-1510 WHT	
N705	H03-WN16AB100WH-R	CONNECT WAFER 2.0mm 16P 35237-1610 WHT	
P714	H03-WN16DI00000-R	GF120-16S-TS 1.25mm 16P	
N702 N710	H03-WN19AB00000-R	CONN 2.0MM 19 MA R NAT SOCKET MOLEX 35237-1910	
P701	H03-WN22DI00000-R	GF120-22S-TS 1.25mm 22P	

Ref. Designator	Part Number	Description	
FRONT PCB ASS'Y			
P708	H03-WN29DI00000-R	CONNECT 1.25MM 29PIN GF120-29S-TS	
BK10	H03-ZMD27S09A00-R	BRACKET BKT XM	
BD2 BD3 BD16 BD42	H03-FB05B3580NN-R	BEAD AXIAL/TAP,HC3580 80.5ohm	
L301 L302 L303 L304	H03-LAINB0470CR-R	LF 47U0H +10% 5.8 OHM 500MIOA	
L101 L102 L103 L105 L107 L108 L421	H03-LAINB047ACR-R	LF 4U7H +10% 1.7 OHM 190.0A	
<i>Capacitors</i>			
C119 C128 C551	CCZID0104NA-R	CC 100N0F +80% -20% 50.0V F	
C517	H03-CEHEC02275E-R	CE 220UF +20% 10.0V P=5MM 85C SK 220/10V 5 X11	
C718	H03-CEHFC04765E-R	CE47UF +20% 16.0V D5XL11 P5MM 85C SK 47/16V 5 X11	
C503 C504	H03-CEHFC01062S-R	CE 10UF +20% 16V D4XL7 P2.5MM 2000hours 85C	
C501 C502	H03-CEHFC04762S-R	CE 47UF +20% 16V D5XL7 P2.5MM 2000hours 85C	
C125 C126	H03-CFHKA0473NN-R	CAP POLYESTER METAL 47NF 100V 20% CPM	
C127	CEHFC0107NN-R	CE 100U0F +20% 16.0V 85C	
C708	H03-CEHFC01072S-R	CE 100UF +20% 16V D6.3XL7 P2.5MM 2000hours 85C	
C701 C704 C706	CZDII0100CE-R	CAP CERAMIC/CHIP 10PF 50V CH D N 0805	
C120 C121 C122 C400 C401 C403 C404 C717 C725 C726 C727 C900	CZJII0101BE-R	CAP CHIP 100P0F +5% -5% 50.0V NPO 0603	
C702	CZJII0101CE-R	CAP CERAMIC/CHIP 100PF 50V CH J NPO 0805	
C703 C705	CZJII0122CC-R	CAPCHIP 1n2F 50V SL J X7R 0805 +/-5%	
C300 C301	CZJII0821CE-R	CAP CHIP 820pF 50V SL J NPO 0805	
C506	CZKII0221BA-R	CAP CHIP 220PF 50V K SL 0603	
C252 C253	CZKII0222BC-R	CAP CHIP 2N2F +10% -10% 50.0V X7R 0603	
C201 C211	CZKII0223BC-R	CAP CHIP 22N0F +10% -10% 50.0V X7R 0603	
C1 C2 C124 C251 C254 C405 C406 C407 C411 C521 C552 C553 C580 C581 C582 C709 C723	CZZFI0104BF-R	CAP CHIP 100N0F +80% -20% 16.0V Y5V 0603	
<i>Semiconductors</i>			
D853 D854 D855 D856	H03-DL30B2015AA-R	D-LEM 30B3-20-15 GaN SUPER BLUE WATER CLEAR 15 ML37B23H-CED	
D831	H03-DL3BA05V0BA-R	D-LEM BLUE/AMBER 3PIE RD RND L-3VYMBC	
D800 D801	H03-DLRED3FRDBA-R	D-LEM RED/GREEN 3F RD RND CL	
D301	H03-DG1N04148NB-R	D-SLP 1N4148 100.0V 150E-3A	
Q821	H03-TRMPSA06NNA-R	TR-SLPLF MPSA06 NPN 500MIOA TO-92	
Q823	H03-TRMPSA56YNA-R	TR-SLPLF MPSA56 Y PNP -500MIOA -300V	
D251 D252 D411 D412 D701 D715 D721 D722	H03-DS1S50094NB-R	D-SLP 1SS355 35.0V 225MIOA	
D110	H03-DSUDZ05V1NB-R	DIODE ZENER UDZ5.1B 5.1V 200MIOW	
Q703	H03-TRKTA1504ND-R	TRANSISTOR PNP KTA1504Y(S)SOT-23	
Q701 Q702	H03-TRKTC3875ND-R	TRANSISTOR NPN KTC3875S SOT23	
Q824 Q831 Q832	H03-TSKRA107SNI-R	KRA107S SOT-23 PNP	
Q800 Q801 Q802 Q803 Q820 Q822 Q833	H03-TSKRC107SND-R	KRC107S SOT-23 NPN	
IC50	H03-ICLM02068D2-R	IC-OPERAMP NJM2068M-TE1 DUAL OP-AMP SOP8	
D716	H03-DR1N04004NA-R	D-SR 1N4004 400.0V 1.0A	
RM72	H03-DPLP200LNNN-R	PIN PHOTO DIODE LP-200TL	
<i>Resistors</i>			
R118 R119	RC3DI0100IN-R	RCF 10R0 OHM +5% 250MIOW	
R122 R123 R501 R502	RC3DI0101IN-R	RCF 100R0 OHM +5% 250MIOW	
R831	RC3DI0151IN-R	RCF 150 OHM 5% 1/4W	
R518	RC3DI0182IN-R	RCF 1K8 OHM 5% 1/4W	
R801 R803	RC3DI0201IN-R	RCF 200R0 OHM +5% 250MIOW	
R251 R252	RC3DI022AIN-R	RCF 2R2 OHM +5% 250MIOW	
R800 R802	RC3DI0271IN-R	RCF 270R0 OHM +5% 250MIOW	
R832	RC3DI0331IN-R	RCF 330R0 OHM +5% 250MIOW	

Ref. Designator	Part Number	Description	
FRONT PCB ASS'Y			
R120 R121	RC3DI04711N-R	RCF 470R0 OHM +5% 250MI0W	
R751	RC3DI0473IN-R	RCF 47K OHM +5% 250MI0W	
R851 R852	RC3DI05611N-R	RCF 560R0 OHM +5% 250MI0W	
R505 R841 R842 R843 R844 C724	RS3AD0000NA-R	RES CHIP, 0 R 1/16W +/-5%, 0603	
R521 R522 R722 R746	RS3AD0101NA-R	RES CHIP,100R 1/16W +/-5%,0603	
R201 R211 R503 R515 R721 R824	RS3AD0102NA-R	RES CHIP,1K 1/16W +/-5% ,0603	
R702 R704 R709 R822	RS3AD0103NA-R	RES CHIP,10K 1/16W +/-5% ,0603	
R516	RS3AD0104NA-R	RES CHIP,100K 1/16W +/-5% ,0603	
R706 R707	RS3AD0105NA-R	RES CHIP 1M 1/16W +5% 0603	
R202 R212	RS3AD0122NA-R	RMGCFMIC 1K2 OHM +5% 0603	
R203 R213	RS3AD0152NA-R	RES CHIP 1K5 1/16W +5% 0603	
R209 R219	RS3AD0183NA-R	RMGCFMIC 18K0 OHM +5% 0603	
R823	RS3AD0221NA-R	RMGCFMIC 220R0 OHM +5% 0603	
R204 R214 R510 R519	RS3AD0222NA-R	RMGCFMIC 2K2 OHM +5% 0603	
R205 R215 R703	RS3AD0272NA-R	RMGCFMIC 2K7 OHM +5% 0603	
R206 R216 R506	RS3AD0332NA-R	RMGCFMIC 3K3 OHM +5% 0603	
R509	RS3AD0472NA-R	RES CHIP,4K7 1/16W +/-5%,0603	
R520	RS3AD0473NA-R	RES CHIP,47K 1/16W +/-5%,0603	
R207 R217	RS3AD0562NA-R	RMGCFMIC 5K6 OHM +5% 0603	
R821	RS3AD0563NA-R	RES CHIP, 56K 1/16W +/-5%, 0603.	
R301 R302 R701	RS3AD0683NA-R	RMGCFMIC 68K0 OHM +5% 0603	
R208 R218	RS3AD0822NA-R	RMGCFMIC 8K2 OHM +5% 0603	
R508	RS3AD0911NA-R	RMGCFMIC 910 OHM +5% 0603	
R705	RS3BB0564NA-R	RES,CHIP,560K OHM,1/10W +/-5%,0805	
R461 R462	RS3AD0753NA-R	RES CHIP 75K 1/16W +5% 0603.	
<i>Miscellaneous</i>			
VR10	H03-SWE3A0505S1-R	SWIROT EC16B24204A9 5V 500U0A 10T 3P 0 0	
NJ71	H03-SO3P5179NNN-R	JACK PHONE 3.5PI PJ0435179N	
NJ70	H03-SORA1JE01NN-R	JACK RCA 1P JE010003MN GND OR	
NJ11	H03-SORA3313PNN-R	CON PHONO SCKT RCA-313P 3 PINS	
NJ12	H03-SORA8OSC5N8-R	JACK S-VIDEO 1P C40160261N	
NJ10	H03-SOSS9CKX3NN-R	JACK PHONE 6.35 H70980110S 9P BK	
NJ79	H03-SOTORX177LT-R	FIBER OPTIC RECEIVING TORX177L (F, T)	
N207	H03-WE11B041000-R	WIRE ASS'Y UL1007#26 410MM 2.0MM 11P WHT	
N201	H03-WG03AB80900-R	WIRECONASY DL 2.0MM 03P 90MM ANG-DOWN UL1007 RIBBON 26 1 B20	
N206	H03-WG05SB83500-R	WIRE ASS'Y UL1007#26(TA) 350mm 2.0mm 5p GRY	
N203	H03-WG13SB82000-R	UL1007#26 STR 200mm 2.0mm 13P WHT	
P213	H03-WN04SB00000-R	CONNECT 2.0mm 4P GIL-S-4P-S2T2-EF	
P215	H03-WN06SB01000-R	CNT PLUG BD'BD PLUG 2.0mm 35336-0610	
P209	H03-WN07AB00000-R	CONNECT 2.0MM 7P GIL-S-07P-S2L2-EF	
N214	H03-WN19AB00000-R	CONN 2.0MM 19 MA R NAT SOCKET MOLEX 35237-1910	
P216	H03-WN19SB00000-R	CONN 2.0MM 19 MA ST NAT MOLEX 35336-1910 0 0	
N205	H03-WN22AI00000-R	GF120-22S-LS 1.25mm 22P	
N204	H03-WS4261005FN-R	WIRE ASS'Y UL2547/1007#26 100MM 4P 2.0MM WHT	
N202	H03-WS4265913FN-R	CNT ASSY 2.0MM 4P 590MM SHIELD 26AWG UL2547 1/3	
N210	H03-WS5263805NG-R	WIRE ASS'Y UL2547#26(TA) 380mm 2.0mm 5P GRY	
N212	H03-WS5248505CW-R	WIRE ASS'Y UL1007/1533#24(TA)850mm 2.0mm 5P WHT	
N208	H03-WS6265105EN-R	WIRECONASY DL 2.0MM 6P 510MM UL1533 SHIELD 26 1	
N211	H03-WS7260805EN-R	WIRE ASS'Y UL1533/1007#26 80MM 2.0MM 7P WHT SHILED	
FL1	H03-XD18BT19GNA-R	18-BT-19GINK	
S1 S2 S3 S4 S5 S6 S7 S8 S9	H03-ZMB01S02200-R	SPRING PLATE GND C5212 0.2T	
M2	H03-ZMC12S17A00-R	AC PUN SHIELD DIGITAL ET	
M3	H03-ZMD12S01A00-R	SHIELD IR	
M4	H03-ZMD12S01B00-R	SHIELD MICROPHONE	
RM72	ZFNR1SENSOR-R	RUBBER SENSOR	
RM71	H03-ICROMN338EC-R	REMOCON RECEIVER MODULE ROM-N338TEC	
L251	H03-LAINB0470CR-R	LF 47U0H +10% 5.8 OHM 500MI0A	
L120	H03-LAINB047ACR-R	LF 4U7H +10% 1.7 OHM 190.0A	

Ref. Designator	Part Number	Description	
FRONT PCB ASS'Y			
L700	H03-FB2522012HF-R	FCM2012HF-252T02 2500ohm SURFACE MT 2012	
S201 S202 S203 S204 S205 S206 S207 S208 S209 S210 S211 S212 S213 S214 S215 S216 S217 S218 S219 S220	H03-SWC2A112FS1-R	SWITACT VERTICAL SKQNADD010	
MAIN PCB ASS'Y			
<i>Capacitors</i>			
C517	CEHIA0228MN-R	CE 2M2F +20% 50.0V 85C	
C571 C572	H03-CEMJA0159KA-R	CAP ELEC 15000uF 63V M 35x50 LSW153M1JQ50M	
C101 C102 C103 C104 C107 C108 C109 C110 C111 C112 C113 C114 C115 C116 C117 C118 C205	CCKID0101NA-R	CC 100P0F +10% -10% 50.0V Y5P	
C307 C308 C313 C314 C403 C404 C569 C570	CCKID0271NN-R	CC 270P0F +10% -10% 50.0V 2B4	
C433	CCMFD0103NN-R	CC 10N0F +20% -20% 16.0V Y5S	
C119 C120 C203 C212 C214 C527 C531 C709 C711 C712 C713	CCZID0104NA-R	CC 100N0F +80% -20% 50.0V F	
C315 C316 C409 C410	CCCIC0030NN-R	CAP CERAMIC 3PF 50V C CH TAP	
C317 C318 C411 C412	CCKIC0181NA-R	CC 180P0F +10% -10% 50.0V Y5P	
C329 C330 C425 C426	CCKIC0222NA-R	CC 2N2F +10% -10% 50.0V Y5P	
C707	CCZGC0104NA-R	CAP CERAMIC 100NF 25V Z Z5U TAP	
C323 C324 C430 C431	CFLJC0683NN-R	CPM 68N0F +5% 63.0V	
C506 C507 C508 C516 C528 C529 C701 C702 C703	CPIKC0473NN-R	CPF 47N0F +10% 100.0V	
C331 C332 C407 C408	H03-CEHEC02275E-R	CE 220UF +20% 10.0V P=5MM 85C SK 220/10V 5 X11	
C206 C208 C213 C309 C310 C405 C406 C526 C710	H03-CEHGC01075E-R	CE 100U0F +20% 25.0V 6.3X11 85C P5MM SK 100/25V 6.3 X11	
C210	H03-CEHIC01055E-R	CE 1UF +20% 50V D5XL11 P5MM 85C SK 1/50V 5 X11	
C301 C302 C401 C402 C518 C519 C521 C530 C708 C429	H03-CEHIC01065E-R	CE 10U0F +20% 50.0V 85C P5MM 5X11 SK 10/50V 5 X11	
C207	H03-CEHIC04755E-R	CE 4U7F +20% 50.0V 85C P5MM SK 4.7/50V 5 X11	
C303 C304 C305 C306 C421 C422 C423 C424	H03-CEHJA0477MN-R	CE 470U0F +20% 63.0V 85C SK 470/63V 13 X21	
C432	H03-CEMGC04775E-R	CE 470U0F +/-20% 25.0V 10X13 85C SK 470/25V 10 X13	
C211 C319 C320 C321 C322 C413 C414 C415 C416	H03-CEMKC0106AH-R	CAP ELEC 10UF 100V M 6.3X11 SHL	
C573	H03-CEMDC0478KA-R	CAP ELECTROYTIC 4700UF 6.3V M 12.5X21 (SKP472M0J121R)I	
C325 C326 C327 C328 C417 C418 C419 C420	H03-CPJJC0104NN-R	CAP POLYESTER NON METAL 0.1uF 63V J TAP PCMT365 76104	
C509 C510	H03-CEHHC0228MN-R	CE 2200UF +20% 35.0V 85C 16X25	
C705 C706	H03-CEMFA0688BK-R	CAP ELEC 6800UF 16V M 16X25 85C 120HZ SK 6800/16V 16 X25	
C333 C335 C336 C434	CCKIC0103NA-R	CC 10N0F +10% -10% 50.0V Y5P	
C105 C106	CZZFI0104BF-R	CAP CHIP 100N0F +80% -20% 16.0V Y5V 0603	
C201 C202	CZJII0101BE-R	CAP CHIP 100P0F +5% -5% 50.0V NP0 0603	
<i>Semiconductors</i>			
D502 D505	H03-DU2W04MMF00-R	DIODE 2W04M-MF RC-2 Kink Type	
D701	H03-DUKBU6GMF6N-R	KBU6G-MF RS-6 Kink Type	
IC73	H03-ICKIA278R06-R	IC VOLTAGE REGULATOR KIA278R06PI TO-220IS-4	
IC71	H03-ICKIA278R33-R	IC VOLTAGE REGULATOR KIA278R33PI TO-220IS-4	
IC72	H03-ICKIA7805I2-R	IC-REGPOSFVD VOLTAGE REGULATOR KIA7805API TO-220IS	
IC59	H03-ICKIA7812I2-R	IC-REGPOSFVD VOLTAGE REGULATOR KIA7812API	
IC54	H03-ICKIA7824I2-R	IC-REGPOSFVD VOLTAGE REGULATOR KIA7824API TO-220IS	
IC51 IC60	H03-ICLM07815BD-R	IC-REGPOSFVD VOLTAGE REGULATOR KIA7815API	
IC52	H03-ICLM07915BD-R	IC-REGNEGFXD VOLTAGE REGULATOR KIA7915API TO-220AB	
Q329 Q330 Q433 Q434	H03-TR2SA1859BC-R	TR-SHPLF 2SA1859A PNP -2.0A	
Q335 Q336 Q439 Q440	H03-TR2SA1986AC-R	TRANSISTOR PNP 2SA1986-R(AC,F) HFE:55-110	
Q331 Q332 Q435 Q436	H03-TR2SC4883BC-R	TR-SHPLF 2SC4883A NPN 2.0A	

Ref. Designator	Part Number	Description
MAIN PCB ASS'Y		
Q333 Q334 Q437 Q438	H03-TR2SC5358AC-R	TRANSISTOR NPN 2SC5358-R(AC,F) HFE:55~110
Q327 Q328 Q431 Q432	H03-TRKTA1360BE-R	TRANSISTOR PNP KTA1360 TO-126
Q701 Q702 Q703 Q704	H03-TRKTC3114NE-R	TRANSISTOR NPN KTC3114 TO-126
Q323 Q324 Q429 Q430	H03-TRKTC3423BE-R	TRANSISTOR NPN KTC3423 TO-126
D104 D205 D206 D301 D302 D303 D304 D305 D306 D307 D308 D401 D402 D403 D404 D405 D406 D407 D408 D409 D410 D411 D412 D603	H03-DG1N04148NB-R	D-SLP 1N4148 100.0V 150E-3A
D101 D102 D103 D508 D509 D703	H03-DR1N04004NA-R	D-SR 1N4004 400.0V 1.0A
D204	H03-DZGE12V10MA-R	MZ0.5GE12V-10 12V 10mA
D207	H03-DZGE3V320MA-R	DIODE ZENER MZ0.5GE3V3-20 3.3V 20mA
Q309 Q310 Q411 Q412	H03-TR2SA1145YF-R	TRANSISTOR PNP 2SA1145-Y(F) TO-92 HFE:120~240
Q443	H03-TRKRC107MNA-R	TR-SLPSWA KRC107M NPN
Q315 Q316 Q319 Q320 Q417 Q418 Q421 Q422 Q442	H03-TRKTA1024NA-R	TR-SLPLF KTA1024 Y PNP 50MIOA -150V
Q311 Q312 Q410 Q413 Q414	H03-TRKTA1268NA-R	TR-SHPLF KTA1268BL PNP 100MIOA 120V
Q307 Q308 Q407 Q408 Q426 Q441	H03-TRKTC3198NA-R	TR-SLPLF KTC3198BL NPN 150MIOA
Q301 Q302 Q303 Q304 Q305 Q306 Q313 Q314 Q337 Q338 Q401 Q402 Q403 Q404 Q405 Q406 Q409 Q415 Q416 Q425	H03-TRKTC3200NA-R	TR-SHPLF KTC3200BL NPN 100MIOA 120V
Q317 Q318 Q321 Q322 Q419 Q420 Q423 Q424	H03-TRKTC3206NA-R	TR-SLPLF KTC3206 Y NPN 50MIOA 150V
Q601	H03-TRKTD1302NA-R	TR-SLPLF KTD1302 B NPN 300MIOA 20V
D210	H03-DS05GBUSCNB-R	DIODE PG05GBUSC
IC22	H03-ICLM02068D2-R	IC-OPERAMP NJM2068M-TE1 DUAL OP-AMPSOP8
<i>Resistors</i>		
R378 R379 R471 R472	H03-RI3IC022BEN-R	RW 220MIO OHM +5% 5.0W 100PPM/C -100PPM/C
R392 R393 R475 R476	H03-RM3FC0100BN-R	RES METAL OXIDE 10R OHM+5% 1.0W
R514 R517 R518	H03-RM3GC022ACN-R	RESISTOR METAL OXIDE 2R2 OHM +5% 2.0W
R504 R507 R510 R715 R716 R703 R704	H03-RM3GC033ACN-R	RESISTOR METAL OXIDE 3R3 OHM +5% 2.0W
R505	H03-RM3GC047ACN-R	RESISTOR METAL OXIDE 4R7 +5% 2.0W
VR74	H03-RT7EA0201NB-R	PR 200R0 OHM +20% 500MIOW
R351 R352 R367 R368 R445 R446 R447 R448	H03-RM3EG0100LN-R	RMF 10R0 OHM +5% 500MIOW
G102 G103	H03-ZNMSA4004SN-R	TERMLUG GND
R303 R304 R388 R389 R473 R474 R477 R478	RC3DI0100IN-R	RCF 10R0 OHM +5% 250MIOW
R213 R221 R353 R354 R369 R370 R457 R458 R459 R460 R717	RC3DI0101IN-R	RCF 100R0 OHM +5% 250MIOW
R211 R508 R601	RC3DI0102IN-R	RCF 1K0 OHM +5% 250MIOW
R485 R706 R714	RC3DI0103IN-R	RCF 10K0 OHM +5% 250MIOW
R207 R214 R216 R217 R218 R219 R220 R309 R310 R479 R480 R602	RC3DI0104IN-R	RCF 100K0 OHM +5% 250MIOW
R103 R104	RC3DI010AIN-R	RCF 1R0 OHM +5% 250MIOW
R363 R364 R365 R366 R461 R462 R463 R464	RC3DI0150IN-R	RCF 15R0 OHM +5% 250MIOW
R380 R381 R386 R387 R481 R483 R488 R490	RC3DI0152IN-R	RCF 1K5 OHM +5% 250MIOW
R341 R342 R343 R344 R384 R385 R437 R438 R439 R440 R482 R489	RC3DI0153IN-R	RCF 15K0 OHM +5% 250MIOW
R311 R312 R313 R314 R405 R406 R407 R408	RC3DI0162IN-R	RCF 1K6 OHM +5% 250MIOW

Ref. Designator	Part Number	Description	
MAIN PCB ASS'Y			
R339 R340 R345 R346 R347 R348 R349 R350 R433 R434 R435 R436 R441 R442 R443 R444	RC3DI0201IN-R	RCF 200R0 OHM +5% 250MI0W	
R215 R317 R318 R319 R320 R321 R322 R409 R410 R411 R412 R413 R414	RC3DI0221IN-R	RCF 220R0 OHM +5% 250MI0W	
R390 R391 R486 R492	RC3DI0223IN-R	RCF 22K0 OHM +5% 250MI0W	
R107 R108 R371 R372 R373 R374 R465 R466 R467 R468 R616	RC3DI022AIN-R	RCF 2R2 OHM +5% 250MI0W	
R497	RC3DI0271IN-R	RCF 270R0 OHM +5% 250MI0W	
R209 R498 R506	RC3DI0273IN-R	RCF 27K0 OHM +5% 250MI0W	
R224	RC3DI0274IN-R	RCF 270K0 OHM +5% 250MI0W	
R701 R707 R710 R711	RC3DI0282IN-R	RCF 2K8 OHM +5% 250MI0W	
R301 R302 R401 R402	RC3DI0331IN-R	RCF 330R0 OHM +5% 250MI0W	
R225 R305 R306 R403 R404 R509 R515	RC3DI0333IN-R	RCF 33K0 OHM +5% 250MI0W	
R382 R383 R484 R487 R491	RC3DI0393IN-R	RCF 39K0 OHM +5% 250MI0W	
R307 R308 R415 R416	RC3DI0433IN-R	RCF 43K0 OHM +5% 250MI0W	
R101 R102 R105 R106 R109 R110 R113 R114 R315 R316 R593 R594 R718	RC3DI0471IN-R	RCF 470R0 OHM +5% 250MI0W	
R223	RC3DI0513IN-R	RCF 51K0 OHM +5% 250MI0W	
R323 R324 R325 R326 R329 R330 R333 R334 R335 R336 R337 R338 R421 R422 R423 R424 R425 R426 R427 R428 R429 R430 R431 R432	RC3DI0561IN-R	RCF 560R0 OHM +5% 250MI0W	
R375 R376 R469 R470	RC3DI0820IN-R	RCF 82R0 OHM +5% 250MI0W	
R702 R705 R708 R709	RC3DI0751IN-R	RCF 750R0 OHM +5% 250MI0W	
R493	RC3DI0822IN-R	RCF 8K2 OHM +5% 250MI0W	
R331 R332 R419 R420	RM1DI0152IN-R	RMF 1K5 OHM +1% 250MI0W	
R327 R328 R417 R418	RM1DI0333IN-R	RMF 33K0 OHM +1% 250MI0W	
VR71 VR72 VR73	RT6BA0201NB-R	PR 200R0 OHM +30% 100MI0W	
<i>Miscellaneous</i>			
NJ81	H03-SOPA81900NN-R	CONN-SPE TERMINAL SPKR 8P SH081136JP FE 19MM 8 -- 0 0	
NJ83	H03-SORA40RSANN-R	JACK RCA 4P JB040131ZN GN BN PP TA	
NJ82	H03-SORA40RSCNN-R	JACK RCA 4P JB040131QN WH BU RD GY	
L301 L302 L401 L402	H03-LC>NNNA050NA-R	LFA 1MM 10MM 5 LEFT 0.0MM NONE SP-2516	
N814	H03-WG03SE03700-R	WIRE ASS'Y UL1007#16(TA) 370mm 3P GRY	
P503 P805 P806 P809 P817 P818	H03-WN02SD00000-R	CONN 2.5MM 2 MA ST NAT 5267-02A 0 0	
N819 N820 N821 N823	H03-WN04AB100WH-R	CONN WAFER 2.0MM 4P 35237-0410 WHT	
P801 P802 P803 P804	H03-WN04SB100WH-R	CONN WAFER 2.0MM 4P 35336-0410 WHT	
P808	H03-WN05SD100WH-R	CONN WAFER 2.5MM 5P 5267-05A WHT	
P815	H03-WN07SB100WH-R	CONN WAFER 2.0MM 7P 35336-0710 WHT	
N822	H03-WN09AB100WH-R	CONNECT WAFER 2.0mm 9P 35237-0910 WHT	
P811	H03-WN09SB100WH-R	CONNECT WAFER 2.0mm 9P 35336-0910 WHT	
P816	H03-WN10SB100WH-R	CONNECT WAFER 2.0mm 10P 35336-1010 WHT	
P812	H03-WN13SB00000-R	CONN 2.0MM 13P GIL-S-13P-S2T2	
P813	H03-WN19SB00000-R	CONN 2.0MM 19 MA ST NAT MOLEX 35336-1910 0 0	
	H03-ZMD27HS0400-R	H/SINK REG. TR	
F501 F502 F505 F506	H03-FURN22000SR-R	FUSE SR-5 SERIES 3821200 SR-5-2A 250V 35A	
F701 F702	H03-FURN23150SR-R	FUSE SR-5 SERIES 3821315 SR-5-3.15A 250V 35A	

Ref. Designator	Part Number	Description	
MAIN PCB ASS'Y			
NJ84	SO0A18P8CNN-R	JACK-TELE SNAP-IN GOLDEN TELECOM GDL1-8P8C 8T BK 0 0	
	ZNSSM3023HZ-R	NUT M3 ZN PLATED	
	ZSMBM3014BZ-R	SCREW M.S M3X14 ZN PLATED	
	ZSTBM3010BB-R	SCREW ST BH 3X10	
N706	H03-WG02SD03801-R	WIRE ASS'Y,UL1007#24(TA) GRY 380mm 2.5mm 2P	US
N807	H03-WG05AB81900-R	WIRE ASS'Y UL1007#26(TA)190MM 2.0MM 5P WHT	
	H03-ZH740MSQ6WH-R	MICA SHEET SIZE 19X22X0.05	
PO71	H03-ICLM19CIZIE-R	IC TEMPERATURE SENSOR LM19CIZ 2.4V TO-92	
PROCESSOR PCB			
<i>Capacitors</i>			
C125 C126 C127 C128 C141 C143 C144 C146 C190 C191 C206 C207 C212 C213 C220 C221 C226 C227 C230 C231 C232 C233 C251 C252 C253 C254 C301 C302 C303 C304 C307 C308 C309 C310 C508 C510 C517 C518 C521 C522 C528 C529 C534 C535 C601 C602 C611 C612 C617 C618 C621 C622 C627 C628 C631 C632 C637 C638 C641 C642 C647 C648	CEHFC0106NN-R	CE 10U0F +20% 16.0V 85C	
C175 C176 C193	CEHIC01055E-R	CE 1UF +20% 50V D5XL11 P5MM 85C	
C607 C608	H03-CEMGC0337AH-R	CAP ELEC 330UF 25V M 8X11.5 AHS	
C214 C215 C609 C610	CEHFC0107NN-R	CE 100U0F +20% 16.0V 85C	
C101 C102 C103 C104 C116 C117 C118 C119 C121 C122 C123 C124 C131 C132 C133 C134 C136 C137 C138 C139 C147 C148 C149 C150 C152 C153 C154 C155 C156 C157 C158 C159 C194 C195 C196 C197 C201 C202 C204 C205 C210 C211 C216 C217 C218 C219 C531 C603 C604	CZJII0101BE-R	CAP CHIP 100P0F +5% -5% 50.0V NP0 0603	
C281 C282	CZJII0121BE-R	CAP CHIP 120PF 50V J NPO 0603	
C208 C209 C222 C223 C624 C644	CZJII0151BE-R	CAP CHIP 150PF 50V J NPO 0603	
C532 C533	CZJII0330BE-R	CAP CHIP 33P0F +5% -5% 50.0V NP0 0603	
C12 C13 C14 C15 C16 C17 C18 C19 C120 C135 C203	CZZFI0104BF-R	CAP CHIP 100N0F +80% -20% 16.0V Y5V 0603	
C224 C225 C238 C315 C316 C503 C506 C519 C520 C530 C540	CZJII0101BE-R	CAP CHIP 100P0F +5% -5% 50.0V NP0 0603	
C591 C592 C613 C614 C623 C633 C643	CZJII0151BE-R	CAP CHIP 150PF 50V J NPO 0603	
C605 C606	CZJII0271BE-R	CAP CHIP, 270PF 50V +/-5% CH J 0603	
C615 C616	CZJII0330BE-R	CAP CHIP 33P0F +5% -5% 50.0V NP0 0603	
C634 C636	CZKII0222BC-R	CAP CHIP 2N2F +10% -10% 50.0V X7R 0603	
C10 C11 C20 C21	CZZFI0104BF-R	CAP CHIP 100N0F +80% -20% 16.0V Y5V 0603	
C625 C626 C635 C645 C646	CZJII0560BE-R	CAP CHIP 56PF 50V CH J NPO 0603	
<i>Semiconductors</i>			
IC2 IC3 IC4 IC5 IC6 IC7 IC10 IC11 IC25	H03-ICLM02068D2-R	IC-OPERAMP NJM2068M-TE1 DUAL SOP8	
IC1	H03-ICNJM4580D2-R	IC OP AMP NJM4580M-TE1 SOP8 DUAL OP-AMP	
IC8	H03-ICTC9273CFG-R	TC9273CFG-004 SOP28 ANALOG SWITCH ARRAY ICs	
Q601 Q602 Q621 Q622 Q624 Q625 Q627 Q628 Q630 Q631	H03-TRKTD1304ND-R	TR-SLPSWA KTD1304 NPN 20V 300MIOA SOT-23	

Ref. Designator	Part Number	Description	
PROCESSOR PCB			
Q109 Q203 Q301 Q605 Q608 Q611 Q614 Q615 Q618 Q620 Q623 Q626 Q629	H03-TSKRA107SNI-R	KRA107S SOT-23 PNP	
IC20	H03-ICNJM4556B2-R	IC OP AMP NJM4556AD DUAL OP-AMP DIP8	
D351 D601	H03-DZGE9V120MA-R	MZ0.5GE9V1-20 9.1V 20mA	
IC13 IC14 IC18 IC19 IC21 IC22 IC23 IC24	H03-ICLM02068D2-R	IC-OPERAMP NJM2068M-TE1 DUAL SOP8	
IC15	H03-ICTC9162CDA-R	IC CMOS DIGITAL TC9162CFG SOP28 HIGH VOLTAGE ANALOG FUNCTION SWITCH ARRAY	
IC12	H03-ICTC9163CDA-R	IC CMOS DIGITAL TC9163CFG SOP28 HIGH VOLTAGE ANALOG FUNCTION SWITCH ARRAY	
IC9	H03-ICTC9273CFG-R	TC9273CFG-004 SOP28 ANALOG SWITCH ARRAY ICs	
IC16 IC17	H03-ICTC9482BDA-R	IC CMOS DIGITAL TC9482BFG SOP28 SYSTEM ELECTRONIC VOLUME CONTROL	
Q104 Q105 Q107 Q108 Q201 Q202 Q204 Q205 Q302 Q303 Q603 Q604 Q606 Q607 Q609 Q610 Q612 Q613 Q616 Q617 Q690 Q691	H03-TRKTD1304ND-R	TR-SLPSWA KTD1304 NPN 20V 300MIOA SOT-23	
Q692	H03-TSKRA107SNI-R	KRA107S SOT-23 PNP	
<i>Resistors</i>			
R137 R138 R157 R158 R237 R238 R239 R240 R245 R246 R307 R308 R315 R316 R324 R325 R501 R502 R507 R508 R513 R519 R539 R540 R556 R557 R558 R559 R635 R636 R651 R652 R669 R670 R685 R686 R901 R902 R903 R904	RS3AD0000NA-R	RES CHIP, 0 R 1/16W +/-5%, 0603	
R101 R102 R121 R122 R127 R128 R141 R142 R147 R148 R161 R162 R165 R166 R169 R170 R203 R204 R211 R212 R223 R224 R322 R323 R329 R631 R632 R649 R650 R665 R666 R687 R688 R731 R748 R771	RS3AD0102NA-R	RES CHIP,1K 1/16W +/-5% ,0603	
R191 R192 R193 R512 R520 R550 R551	RS3AD0103NA-R	RES CHIP,10K 1/16W +/-5% ,0603	
R103 R104 R123 R124 R129 R131 R132 R136 R143 R144 R151 R152 R153 R154 R163 R164 R167 R168 R171 R172 R183 R184 R185 R186 R189 R194 R195 R196 R197 R198 R199 R200 R207 R208 R213 R214 R227 R228 R241 R242 R303 R304 R305 R306 R311 R312 R313 R314 R518 R524 R537 R538 R548 R554 R555 R603 R604 R609 R610 R629 R630 R641 R647 R648 R657 R658 R663 R664 R677 R683 R684 R689 R690 R749 R750	RS3AD0104NA-R	RES CHIP,100K 1/16W +/-5% ,0603	
R570 R571	RS3AD0122NA-R	RMGCFMIC 1K2 OHM +5% 0603	
R791 R792	RS3AD0152NA-R	RES CHIP 1K5 1/16W +5% 0603	
R704 R710 R716 R722	RS3AD0183NA-R	RMGCFMIC 18K0 OHM +5% 0603	
R553 R705 R706 R711 R717 R718	RS3AD0202NA-R	RMGCFMIC 2K0 OHM +5% 0603	
R611 R612 R613 R614 R691	RS3AD0221NA-R	RMGCFMIC 220R0 OHM +5% 0603	
R615 R616 R701 R702 R707 R708 R713 R714 R719 R720	RS3AD0222NA-R	RMGCFMIC 2K2 OHM +5% 0603	
R712	RS3AD0242NA-R	RMGCFMIC 2K4 OHM +5% 0603	

Ref. Designator	Part Number	Description	
PROCESSOR PCB			
R231 R232	RS3AD0272NA-R	RMGCFMIC 2K7 OHM +5% 0603	
R699 R700	RS3AD0362NA-R	RMGCFMIC 3K6 OHM +5% 0603	
R572 R573	RS3AD0430NA-R	RES CHIP 43R0 OHM +5% 62M15W 0603	
R125 R126 R133 R134 R145 R146 R155 R156 R201 R202 R215 R216 R221 R222 R235 R236 R243 R244 R251 R252 R301 R302 R309 R310 R533 R534 R546 R547 R601 R602 R623 R624 R639 R640 R655 R656 R675 R676	RS3AD0471NA-R	RMGCFMIC 470R0 OHM +5% 0603	
R159 R160 R187 R188 R219 R220 R318 R319 R621 R622 R637 R638 R653 R654 R671 R672 R673 R674 R695 R696 R723 R724 R725 R726 R727 R728 R772 R773 R774 R775 R776 R777 R778 R779 R780 R781 R783	RS3AD0473NA-R	RES CHIP,47K 1/16W +/-5%,0603	
R703 R709 R715 R721	RS3AD0474NA-R	RMGCFMIC 470K0 OHM +5% 0603	
R209 R210 R229 R230	RS3AD0512NA-R	RES CHIP 5K1 1/16W +5% 0603	
R281 R282 R291 R292 R293 R294 R295 R296 R297 R298 R299 R300	RS3AD0823NA-R	RES,CHIP 82K,1/16W,+/-5%,0603	
R217 R218 R619 R620	RS3AD0100NA-R	RMGCFMIC 10R0 OHM +5% 0603	
R793 R794	RS3AD0123NA-R	RES CHIP,12K 1/16W +/-5%,0603	
R247 R248 R249 R326 R327 R328 R330 R331 R503 R504 R505 R509 R510 R511 R560 R561 R562 R643 R644 R659 R660 R679 R680 R730 R740 R743	RS3AD0102NA-R	RES CHIP,1K 1/16W +/-5% ,0603	
R181 R182 R233 R234 R253 R254 R535 R536 R549 R625 R626 R642 R678	RS3AD0104NA-R	RES CHIP,100K 1/16W +/-5% ,0603	
R515 R522	RS3AD0123NA-R	RES CHIP,12K 1/16W +/-5%,0603	
R591 R592 R605 R606 R627 R628	RS3AD0152NA-R	RES CHIP 1K5 1/16W +5% 0603	
R744	RS3AD0183NA-R	RMGCFMIC 18K0 OHM +5% 0603	
R552	RS3AD0202NA-R	RMGCFMIC 2K0 OHM +5% 0603	
R130 R135 R149 R150 R205 R206 R225 R226 R320 R321 R617 R618 R633 R634 R667 R668 R693 R694 R697 R698 R741 R742	RS3AD0222NA-R	RMGCFMIC 2K2 OHM +5% 0603	
R516 R517 R523 R525	RS3AD0332NA-R	RMGCFMIC 3K3 OHM +5% 0603	
R607 R608	RS3AD0432NA-R	RMGCFMIC 4K3 OHM +5% 0603	
R317 R745	RS3AD0474NA-R	RMGCFMIC 470K0 OHM +5% 0603	
R645 R646 R661 R681 R682	RS3AD0562NA-R	RMGCFMIC 5K6 OHM +5% 0603	
R190	RS3AD0753NA-R	RES CHIP 75K 1/16W +5% 0603.	
R662	RS3AD0912NA-R	RMGCFMIC 9K1 OHM +5% 0603	
R514 R521	RS3AD0103NA-R	RES CHIP,10K 1/16W +/-5% ,0603	
<i>Miscellaneous</i>			
NJ1 NJ2 NJ3	H03-SORA64105NN-R	JACK RCA 6P JB060132PN	
N114 N115 N313	H03-WN04AB100WH-R	CONN WAFER 2.0MM 4P 35237-0410 WHT	
P103 P111	H03-WN04SB00000-R	CONNECT 2.0mm 4P GIL-S-4P-S2T2-EF	
P112 P113 P114 P314	H03-WN04SB100WH-R	CONN WAFER 2.0MM 4P 35336-0410 WHT	
P100 P107	H03-WN05SB00000-R	CONNECT 2.0mm 5P GIL-S-5P-S2T2-EF	
N102	H03-WN06AB00001-R	CNT PLUG BD'BD SOCKET 2.0mm 35237-0610	
P109	H03-WN06SB00000-R	CONNECT 2.0mm 6P GIL-S-6P-S2T2-EF	
N104	H03-WN07AB100WH-R	CONN WAFER 2.0MM 7P 35237-0710 WHT	

Ref. Designator	Part Number	Description	
PROCESSOR PCB			
N101	H03-WN10AB000WH-R	CONNECT WAFER 2.0mm 10P 35237-1010 WHT	
P108	H03-WN10SB100WH-R	CONNECT WAFER 2.0mm 10P 35336-1010 WHT	
P106	H03-WN15SB100WH-R	CONNECT WAFER 2.0mm 15P 35336-1510 WHT	
P105	H03-WN16SB100WH-R	CONNECT WAFER 2.0mm 16P 35336-1610 WHT	
P110	H03-WN19SB00000-R	CONN 2.0MM 19 MA ST NAT MOLEX 35336-1910 0 0	
STANDBY POWER SUPPLY			
<i>Capacitors</i>			
C201 C202	H03-CEMJA0109KB-R	CAP ELEC 10000UF 63V M 30X45 LSW103M1JP45M	
C100	CFMVA0104NN-R	CPPMX 100N0F +20% -20%	
C113 C115 C118 C121	CCZID0104NA-R	CC 100N0F +80% -20% 50.0V F	
C102 C103 C104 C108 C109 C110	CCKIC0103NA-R	CC 10N0F +10% -10% 50.0V Y5P	
C101	CCMOC0472NF-R	CC 4N7F +20% -20% 250.0V Y5V	
C306	CPIKC0473NN-R	CPF 47N0F +10% 100.0V	
C302	H03-CEHFC01075E-R	CE 100UF +-20% 16.0V D5XL11 P5MM 85C SK 100/16V 5 X11	
C125	H03-CEHGC0687NN-R	CE 680U0F +20% 25.0V 85C P5MM SK 680/25V 10 X21	
C114	H03-CEHIC01055E-R	CE 1UF +20% 50V D5XL11 P5MM 85C SK 1/50V 5 X11	
C119 C120	H03-CEHIC01065E-R	CE 10U0F +20% 50.0V 85C P5MM 5X11 SK 10/50V 5 X11	
C107 C111	H03-CEMGC04775E-R	CE 470U0F +/-20% 25.0V 10X13 85C SK 470/25V 10 X13	
C116	H03-CEMHC0227AH-R	CAP ELEC 220UF 35V M 8X11.5 SHL SAMYOUNG	
C305	H03-CEMIC01045E-R	CAP ELEC 0.1uF 50v M 5x11 SHL P5MM SK 0.1/50V 5X11	
C307 C308 C309	H03-CEMIC0334AH-R	CAP ELEC 0.33UF M 5X11 SHL 50V SAMYOUNG	
C105	CEMJC02275E-R	CAP ELEC 220UF 63V M 10X16 85C 120HZ ELITE	
C442	H03-CEHFC04765E-R	CE47UF +20% 16.0V D5XL11 P5MM 85C SK 47/16V 5 X11	
C106	H03-CEHIC0107NN-R	CE 100U0F +20% 50.0V 85C P5.0MM	
C203 C204 C205	H03-CFH0A0104NN-R	CAP POLY METAL CPM 100NF 250V 20% TAE YANG	
C313 C314 C316 C317	CZKII0122BC-R	CAP CHIP 1N2F +10% -10% 50.0V X7R 0603	
C303 C304 C311 C312 C315 C443	CZZFI0104BF-R	CAP CHIP 100N0F +80% -20% 16.0V Y5V 0603	
C444 C445 C446	CZJII0101BE-R	CAP CHIP 100P0F +5% -5% 50.0V NP0 0603	
<i>Semiconductors</i>			
D201	H03-DURS10040NA-R	RS1004 RS-10	
IC12	H03-ICKIA7805I2-R	IC-REGPOSF XD KIA7805API VOLTAGE REGULATOR TO-220IS	
IC11	H03-ICKIA78D3A0-R	IC VOLTAGE REGULATOR KIA78D33PI 3.3V TO-220IS	
IC32 IC33	H03-ICPC17T10B1-R	IC PHOTOCOUPLER PC-17T1 DIP4 KODENSHI	
D101 D111	H03-DG1N04148NB-R	D-SLP 1N4148 100.0V 150E-3A	
D102 D103 D105 D106 D107 D108 D109 D112 D113 D117 D118 D121	H03-DR1N04004NA-R	D-SR 1N4004 400.0V 1.0A	
D119 D120	H03-DZGE22V05MA-R	ZENER MZ0.5GE22V-5 22V 5mA	
D116	H03-DZGE4V320MA-R	ZENER MZ0.5GE4V3-20 4.3V 20mA	
D104	H03-DZGE9V120MA-R	ZENER MZ0.5GE9V1-20 9.1V 20mA	
Q301 Q302	H03-TRKTA107MNA-R	TR-SLPSWA KRA107M PNP	
Q101 Q102	H03-TRMPSA06NNA-R	TR-SLPLF MPSA06 NPN 500MIOA TO-92	
IC34	H03-ICBU4052BCF-R	IC CMOS BU4052BCF SOP16 Dual 4-channel analog multiplexer / demultiplexer	
IC31	H03-ICMAX322316-R	IC RS-232 LINE DRIVER MAX3223CDWR SOIC16P	
Q305 Q306	H03-TRKTA1504ND-R	TRANSISTOR PNP KTA1504Y(S)SOT-23	
Q303 Q304	H03-TSKRC107SND-R	KRC107S SOT-23 NPN	
D303 D304 D305 D306 D307 D308 D309 D310	H03-DS1S50094NB-R	D-SLP 1SS355 35.0V 225MIOA	
IC406	H03-ICBU4094BD3-R	IC CMOS BU4094BCF SOP16 8-bit compatible shift / store register	
<i>Resistors</i>			
R115 R116	H03-RM3FC0100BN-R	RES METAL OXIDE 10R OHM+5% 1.0W	
R108	H03-RM3GC0330CN-R	RESISTOR METAL OXIDE 33 OHM +5% 2.0W	

Ref. Designator	Part Number	Description	
STANDBY POWER SUPPLY			
R317	RC3DI0101IN-R	RCF 100R0 OHM +5% 250MI0W	
R103	RC3DI0102IN-R	RCF 1K0 OHM +5% 250MI0W	
R102 R109	RC3DI0103IN-R	RCF 10K0 OHM +5% 250MI0W	
R110	RC3DI0104IN-R	RCF 100K0 OHM +5% 250MI0W	
R106 R107	RC3DI010AIN-R	RCF 1R0 OHM +5% 250MI0W	
R104	RC3DI0153IN-R	RCF 15K0 OHM +5% 250MI0W	
R105	RC3DI0222IN-R	RCF 2K2 OHM +5% 250MI0W	
R112	RC3DI0272IN-R	RCF 2K7 OHM +5% 250MI0W	
R113	RC3DI0470NN-R	REC,CARBON,47,1/4W,+/-5%,SIZE=1/8W	
R314 R315	RC3DI0471IN-R	RCF 470R0 OHM +5% 250MI0W	
R111	RC3DI0562IN-R	RCF 5K6 OHM +5% 250MI0W	
R326 R444 R445 R446 R447 R715	RS3AD0102NA-R	RES CHIP,1K 1/16W +/-5% ,0603	
R306 R318 R319 R325	RS3AD0103NA-R	RES CHIP,10K 1/16W +/-5% ,0603	
R320 R321 R322	RS3AD0104NA-R	RES CHIP,100K 1/16W +/-5% ,0603	
R327 R328	RS3AD0221NA-R	RMGCFMIC 220R0 OHM +5% 0603	
R312	RS3AD0271NA-R	RMGCFMIC 270R0 OHM +5% 0603	
R310	RS3AD0392NA-R	RMGCFMIC 3K9 OHM +5% 0603	
R309 R311	RS3AD0470NA-R	RMGCFMIC 47R0 OHM +5% 0603	
R313	RS3AD0471NA-R	RMGCFMIC 470R0 OHM +5% 0603	
R303 R304 R305	RS3AD0472NA-R	RES CHIP,4K7 1/16W +/-5%,0603	
R307 R308	RS3AD0473NA-R	RES CHIP,47K 1/16W +/-5%,0603	
R442	RS1AD0101NA-R	RES CHIP 100 OHM 1/16W 1% 0603	
R443	RS3AD0123NA-R	RES CHIP,12K 1/16W +/-5%,0603	
R324	RS3AD0511NA-R	RMGCFMIC 510R0 OHM +5% 0603	
<i>Miscellaneous</i>			
F101	H03-FUGF212A065-R	FUSE 65TS SERIES 250V 12A 326012	US
F201	H03-FUGF23000XX-R	FUSE 239 SERIES 003 250V 3A&3.15A 2183.15MXP	US
F101	H03-FUGF26A30XX-R	FUSVDETIMELG 6.3A 250.0 V 5X20 21806.3MXP	EU
F201	H03-FUGF202A0XX-R	FUSVDETIMELG 2.0A 250.0 V 5X20 218002MXP	EU
SK11	H03-RLL1227111K-R	RELAYPWR SDT-S-112DMR	
NJ33 NJ34 NJ35 NJ36 NJ37	H03-SOJW2350SNN-R	JACK PHONE 3.6 EP-1401A 1P BK	
NS31	H03-SOXA2202DNN-R	A202D0031P 2P	
NS30	H03-SOXA27014NN-R	CON MAINS INLET A/C INLET 7014-NGP	
TP11	H03-TXPWMR740B0-R	AVR POWER TRANSFORMER (ST/BY)-120V	US
TP11	H03-TXPWMEI45B0-R	AVREU POWER TRANSFORMER (ST/BY)-230V	EU
N307	H03-WG04SB82000-R	WIRECONASY DL 2.0MM 4P 200MM UL1007#26 WHT	
P305	H03-WN02SE00000-R	CON 3.96MM PITCH HEADER 2 POS MOLEX 35328-0210	
P301	H03-WN03SE00000-R	CON 3.96MM PITCH MOLEX 35313-0310	
P302	H03-WN05SD100WH-R	CONN WAFER 2.5MM 5P 5267-05A WHT	
P304	H03-WN06SE00000-R	CONNECT 6P 3.96MM 35313-0610	
P303	H03-WN11SB00001-R	CONN 2.0MM 11P GIL-S-11P-S2T2-EF	
N310	H03-WN15AB100WH-R	CONNECT WAFER 2.0mm 15P 35237-1510 WHT	
P308	H03-WN15SB100WH-R	CONNECT WAFER 2.0mm 15P 35336-1510 WHT	
N311	H03-WN16AB100WH-R	CONNECT WAFER 2.0mm 16P 35237-1610 WHT	
P309	H03-WN16SB100WH-R	CONNECT WAFER 2.0mm 16P 35336-1610 WHT	
N312	H03-WN19AB00000-R	CONN 2.0MM 19 MA R NAT SOCKET MOLEX 35237-1910	
P313	H03-WN19SB00000-R	CONN 2.0MM 19 MA ST NAT MOLEX 35336-1910 0 0	
HK11	H03-ZMC12HS0100-R	AC HEATSINK 17*15*30 AVR520 -- ME	
NJ32	SOPA96063NN-R	JACK D-SUB 9P 87204-6063 W/DUST COVER BK	
P306	H03-WN02SE00002-R	CONNECT WAFER,YW396-03V 7.92mm 2P ,DONG HO	
GND1	H03-ZMC12S16A00-R	BKT GROUND	
P351	H03-WN14DI00000-R	CONNECT GF120-14S-TS 1.25MM 14P	
FH10 FH12 FH23 FH24	H03-SOPS1FEHDNN-R	TERMFUSEHLDR FUSE-HOLDER J4210020001X	
G101 G103	H03-ZNMSA4004SN-R	TERMLUG GND	
L301 L302 L303 L304	H03-FB2522012HF-R	FCM2012HF-252T02 2500ohm SURFACE MT 2012	
BD31	H03-FB3012012CF-R	FCM2012CF-301T04 0805	

Ref. Designator	Part Number	Description	
SURROUND PCB			
<i>Capacitors</i>			
C204 C206 C304 C306 C504 C506	CCKID0271NN-R	CC 270P0F +10% -10% 50.0V 2B4	
C207 C307 C507	CCCIC0030NN-R	CAP CERAMIC 3PF 50V C CH TAP	
C209 C309 C509	CKKIC0181NA-R	CC 180P0F +10% -10% 50.0V Y5P	
C215 C315 C517	CCKIC0332NA-R	CC 3N3F +10% -10% 50.0V Y5P	
C607 C608 C611	CCZGC0104NA-R	CAP CERAMIC 100NF 25V Z Z5U TAP	
C601 C602 C603	CPIKC0473NN-R	CPF 47N0F +10% 100.0V	
C210 C310 C510	CPJJC0683NN-R	CAP POLY NON METAL 68NF 63V J TAP	
C208 C308 C508	H03-CEHEC02275E-R	CE 220UF +20% 10.0V P=5MM 85C SK 220/10V 5 X11	
C205 C305 C505	H03-CEHGC01075E-R	CE 100U0F +20% 25.0V 6.3X11 85C P5MM SK 100/25V 6.3 X11	
C101 C203 C303 C503 C609 C610 C614	H03-CEHIC01065E-R	CE 10U0F +20% 50.0V 85C P5MM 5X11 SK 10/50V 5 X11	
C201 C202 C301 C302 C501 C502	H03-CEHJA0477MN-R	CE 470U0F +20% 63.0V 85C SK 470/63V 13 X21	
C604	CEMFA02285E-R	CE 2200UF 16V M 12.5X20 P5MM	
C211 C212 C311 C312 C511 C512	H03-CEMKC0106AH-R	CAP ELEC 10UF 100V M 6.3X11 SHL	
C600	CEMFA0478BK-R	CAP ELEC 4700UF 16V M 16X25 85C 120HZ ELITE	
C213 C214 C313 C314 C513 C514	H03-CPJJC0104NN-R	CAP POLYESTER NON METAL 0.1uF 63V J TAP PCMT365 76104	
C606	H03-CEMFA0688BK-R	CAP ELEC 6800UF 16V M 16X25 85C 120HZ SK 6800/16V 16 X25	
C216 C316 C516	CCKIC0103NA-R	CC 10N0F +10% -10% 50.0V Y5P	
<i>Semiconductors</i>			
Q216 Q316 Q516	H03-TR2SA1859BC-R	TR-SHPLF 2SA1859A PNP -2.0A	
Q219 Q319 Q519	H03-TR2SA1986AC-R	TRANSISTOR PNP 2SA1986-R(AC,F) HFE:55-110	
Q217 Q317 Q517	H03-TR2SC4883BC-R	TR-SHPLF 2SC4883A NPN 2.0A	
Q218 Q318 Q518	H03-TR2SC5358AC-R	TRANSISTOR NPN 2SC5358-R(AC,F) HFE:55-110	
Q215 Q315 Q515	H03-TRKTA1360BE-R	TRANSISTOR PNP KTA1360 TO-126	
Q214 Q314 Q514	H03-TRKTC3114NE-R	TRANSISTOR NPN KTC3114 TO-126	
Q213 Q313 Q513	H03-TRKTC3423BE-R	TRANSISTOR NPN KTC3423 TO-126	
D601	H03-DUKBU6GMF6N-R	KBU6G-MF RS-6 Kink Type	
IC64	H03-ICKIA278R05-R	IC VOLTAGE REGULATOR KIA278R05PI TO-220IS-4	
IC61	H03-ICKIA78D3A0-R	IC VOLTAGE REGULATOR KIA78D33PI 3.3V TO-220IS	
IC63	H03-ICKIA7905I2-R	IC-REGNEGFXD KIA7905PI VOLTAGE REGULATOR	
D101 D201 D202 D203 D204 D301 D302 D303 D304 D501 D502 D503 D504	H03-DG1N04148NB-R	D-SLP 1N4148 100.0V 150E-3A	
D602 D605	H03-DR1N04004NA-R	D-SR 1N4004 400.0V 1.0A	
Q205 Q305 Q505	H03-TR2SA1145YF-R	TRANSISTOR PNP 2SA1145-Y(F) TO-92 HFE:120-240	
Q208 Q211 Q308 Q311 Q508 Q511	H03-TRKTA1024NA-R	TR-SLPLF KTA1024 Y PNP 50MI0A -150V	
Q101 Q206 Q306 Q506	H03-TRKTA1268NA-R	TR-SHPLF KTA1268BL PNP 100MI0A 120V	
Q204 Q304 Q504	H03-TRKTC3198NA-R	TR-SLPLF KTC3198BL NPN 150MI0A	
Q201 Q202 Q203 Q207 Q220 Q301 Q302 Q303 Q307 Q320 Q501 Q502 Q503 Q507 Q520	H03-TRKTC3200NA-R	TR-SHPLF KTC3200BL NPN 100MI0A 120V	
Q209 Q212 Q309 Q312 Q509 Q512	H03-TRKTC3206NA-R	TR-SLPLF KTC3206 Y NPN 50MI0A 150V	
<i>Resistors</i>			
R238 R338 R538	H03-RI3IC022BEN-R	RW 220MI0 OHM +5% 5.0W 100PPM/C -100PPM/C	
R245 R345 R545	H03-RM3FC0100BN-R	RES METAL OXIDE 10R OHM+5% 1.0W	
R601 R602	H03-RM3GC010ACN-R	RESISTOR METAL OXIDE 1R0 OHM +5% 2.0W	
R603 R604	H03-RM3GC039ACN-R	RESISTOR METAL OXIDE 3R9 OHM +5% 2.0W	
VR201 VR301 VR501	H03-RT7EA0201NB-R	PR 200R0 OHM +20% 500MI0W	
R225 R233 R325 R333 R525 R533	H03-RM3EG0100LN-R	RMF 10R0 OHM +5% 500MI0W	

Ref. Designator	Part Number	Description	
SURROUND PCB			
R243 R299 R343 R399 R543 R599	RC3DI0100IN-R	RCF 10R0 OHM +5% 250MI0W	
R226 R236 R326 R336 R526 R536	RC3DI0101IN-R	RCF 100R0 OHM +5% 250MI0W	
R101 R605	RC3DI0103IN-R	RCF 10K0 OHM +5% 250MI0W	
R246 R346 R546	RC3DI0104IN-R	RCF 100K0 OHM +5% 250MI0W	
R228 R235 R328 R335 R528 R535	RC3DI0150IN-R	RCF 15R0 OHM +5% 250MI0W	
R239 R241 R339 R341 R539 R541	RC3DI0152IN-R	RCF 1K5 OHM +5% 250MI0W	
R220 R221 R240 R320 R321 R340 R520 R521 R540	RC3DI0153IN-R	RCF 15K0 OHM +5% 250MI0W	
R209 R210 R309 R310 R509 R510	RC3DI0162IN-R	RCF 1K6 OHM +5% 250MI0W	
R219 R222 R223 R224 R319 R322 R323 R324 R519 R522 R523 R524	RC3DI0201IN-R	RCF 200R0 OHM +5% 250MI0W	
R205 R206 R207 R305 R306 R307 R505 R506 R507	RC3DI0221IN-R	RCF 220R0 OHM +5% 250MI0W	
R244 R344 R544	RC3DI0223IN-R	RCF 22K0 OHM +5% 250MI0W	
R227 R237 R327 R337 R527 R537	RC3DI022AIN-R	RCF 2R2 OHM +5% 250MI0W	
R229 R329 R529	RC3DI0282IN-R	RCF 2K8 OHM +5% 250MI0W	
R201 R301 R501	RC3DI0331IN-R	RCF 330R0 OHM +5% 250MI0W	
R202 R302 R502	RC3DI0333IN-R	RCF 33K0 OHM +5% 250MI0W	
R102 R242 R342 R542	RC3DI0393IN-R	RCF 39K0 OHM +5% 250MI0W	
R204 R304 R504	RC3DI0433IN-R	RCF 43K0 OHM +5% 250MI0W	
R208 R308 R508	RC3DI0471IN-R	RCF 470R0 OHM +5% 250MI0W	
R211 R214 R215 R216 R217 R218 R311 R314 R315 R316 R317 R318 R511 R514 R515 R516 R517 R518	RC3DI0561IN-R	RCF 560R0 OHM +5% 250MI0W	
R234 R334 R534	RC3DI0820IN-R	RCF 82R0 OHM +5% 250MI0W	
R230 R330 R530	RC3DI0751IN-R	RCF 750R0 OHM +5% 250MI0W	
R213 R313 R513	RM1DI0152IN-R	RMF 1K5 OHM +1% 250MI0W	
R212 R312 R512	RM1DI0333IN-R	RMF 33K0 OHM +1% 250MI0W	
<i>Miscellaneous</i>			
L201 L301 L501	H03-LCNNNA050NA-R	LFA 1MM 10MM 5 LEFT 0.0MM NONE SP-2516	
NJ401	H03-SOPA8SH0612-R	JACK SPEAKER 6P SH0612707P GN BN TA	
N502	H03-WG06SE81200-R	WIRE ASS'Y UL1007#16 120mm 3.96mm 6P RED	
P201 P301 P501	H03-WN02AD00000-R	CONNECT WAFER 2.5mm 2P 5268-02A WHT ANGLE	
P506	H03-WN03SB00000-R	CONNECT 2.0mm 3P GIL-S-3P-S2T2-EF	
N503	H03-WN03SD100WH-R	CONN WAFER 2.5MM 3P 5267-03A WHT	
N504	H03-WN05SB00000-R	CONNECT 2.0mm 5P GIL-S-5P-S2T2-EF	
N505	H03-WS6262605EN-R	WIRECONASY DL 2.0MM 6P 260MM UL1533 SHIELD 26 1	
N501	H03-WG07AD02700-R	WIRE ASS'Y,UL1007#20(TA) 270mm 2.5mm 7P WHT	
	H03-ZH740MSQ6WH-R	MICA SHEET SIZE 19X22X0.05	
F601 F602	H03-FURN23150SR-R	FUSE SR-5 SERIES 3821315 SR-5-3.15A 250V 35A	
G101 G102 G105	H03-ZNMSA4004SN-R	TERMLUG GND	
VIDEO PCB			
<i>Capacitors</i>			
C252	CPIIC0223NN-R	CPF 22N0F +10% 50.0V	
C514	CPIIC0682NN-R	CPF 6N8F +10% 50.0V	
C101 C103 C283 C284	H03-CEHDC0108NN-R	CE 1000UF +20% 6.3V 8X11.5 85C P5MM	
C104 C105 C106 C109 C111 C112 C114 C115 C117 C118 C120 C130 C167 C172	H03-CEHEC02275E-R	CE 220UF +20% 10.0V P=5MM 85C SK 220/10V 5 X11	

Ref. Designator	Part Number	Description	
VIDEO PCB			
C128 C129 C131 C132 C133 C134 C135 C136 C169 C170 C270 C271 C278 C279	H03-CEHEC0477MN-R	CE 470U0F +20% 10.0V 85C P=5MM SK 470/10V 6.3 X11	
C601 C604 C607	H03-CEHFC01062S-R	CE 10UF +20% 16V D4XL7 P2.5MM 2000hours 85C	
C243 C245 C251 C257 C277 C288 C292 C296 C300 C304 C308 C349 C356 C536	CEHFC0107NN-R	CE 100U0F +20% 16.0V 85C	
C145 C150 C155 C160 C165 C285 C310 C313 C331 C333 C337 C342	H03-CEHFC04765E-R	CE47UF +20% 16.0V D5XL11 P5MM 85C SK 47/16V 5 X11	
C249 C255 C265 C290 C294 C295 C298 C299 C302 C303 C306 C307 C606	H03-CEHIC01055E-R	CE 1UF +20% 50V D5XL11 P5MM 85C SK 1/50V 5 X11	
C100 C102 C107 C108 C110 C113 C116 C119 C168 C182 C185 C188 C190 C195 C204 C210 C239 C240 C241 C276 C286 C316 C317 C318 C319 C320 C321 C322 C323 C324 C353 C354 C360 C535	H03-CEHIC01065E-R	CE 10U0F +20% 50.0V 85C P5MM 5X11 SK 10/50V 5 X11	
C351 C352 C359	H03-CEHIC02255E-R	CE 2U2F +20% 50V D5XL11 P5MM 85C SK 2.2/50V 5 X11	
C439 C448 C467	H03-CEMFC0226NN-R	CAP ELEC 22UF 16V M P5MM SK 22/16V 5 X11	
C171	CKKIC0121NA-R	120pF 50V Y5P +10% P=5.0MM	
C248	H03-CEHIC0474NN-R	CE 0.47UF +20% 50.0V 85C 5X11 P5MM	
C430 C460 C464 C482 C483 C506 C509 C517	CTMFJ0106ZN-R	CAP TANTAL/CHIP 10uF 16V T491B106K016AS 3528	
C141 C142 C143	CZJII0101BE-R	CAP CHIP 100P0F +5% -5% 50.0V NP0 0603	
C491 C492	CZJII0180BE-R	CAP CHIP 18PF 50V CH J NP0 0603	
C275	CZJII0220BE-R	CCCFMIC 22P0F +5% -5% 50.0V NP0	
C261 C262 C263 C264	CZJII0390BE-R	CAP CHIP 39PF 50V CH J NP0 0603	
C193	CZKFI0823BC-R	CAP CHIP 82NF +/-10% 16V 0603 X7R	
C444 C445 C446 C454 C455 C456 C457 C458 C462 C466 C471 C472 C498 C499 C504 C505 C508 C511	CZKII0102BC-R	CAP CHIP 1N0F +10% -10% 50.0V X7R 0603	
C184 C187 C197 C199 C201 C206 C212 C214 C230 C232 C235 C250 C347 C493 C494 C518	CZKII0103BC-R	CAP CHIP 10N0F +10% -10% 50.0V X7R 0603	
C523	CZKII0392BC-R	3n9F 50V X7R K 0603	
C194	CZKII0822BC-R	CAP CHIP 8N2F +10% -10% 50.0V X7R 0603	
C144 C149 C154 C159 C164 C180 C183 C186 C189 C191 C196 C198 C200 C205 C211 C213 C229 C231 C233 C244 C246 C256 C289 C293 C297 C301 C305 C309 C311 C312 C314 C315 C325 C327 C332 C334 C336 C338 C339 C343 C357 C361 C362 C363 C431 C432 C433 C434 C435 C436 C437 C440 C441 C442 C443 C449 C450 C451 C452 C453 C461 C465 C468 C469 C470 C475 C476 C477 C478 C479 C480 C481 C484 C485 C486 C487 C488 C489 C490 C496 C497 C501 C502 C507 C510 C512 C519 C520 C521	CZZFI0104BF-R	CAP CHIP 100N0F +80% -20% 16.0V Y5V 0603	
C207 C473 C474 C495	CTMFJ0106ZN-R	CAP TANTAL/CHIP 10uF 16V T491B106K016AS 3528	
C247	CZDII0100BE-R	CAP CHIP 10PF 50V CH D NP0 0603	
C236 C237 C267 C268 C269 C282	CZJII0101BE-R	CAP CHIP 100P0F +5% -5% 50.0V NP0 0603	
C273 C340	CZJII0220BE-R	CCCFMIC 22P0F +5% -5% 50.0V NP0	
C254	CZJII0270BE-R	CAP CHIP 27P0F +5% -5% 50.0V NP0 0603	
C253	CZJII0300BE-R	CAPA CHIP 30PF 50V CH NP0 +5% 0603	

Ref. Designator	Part Number	Description	
VIDEO PCB			
C166	CZJII0331BE-R	CAP CHIP 330P0F +5% -5% 50.0V NPO 0603	
C176 C503	CZKII0102BC-R	CAP CHIP 1N0F +10% -10% 50.0V X7R 0603	
C209 C258 C348 C515 C516	CZKII0103BC-R	CAP CHIP 10N0F +10% -10% 50.0V X7R 0603	
C280 C281	CZKII0221BA-R	CAP CHIP 220PF 50V K SL 0603	
C350 C358	CZKII0223BC-R	CAP CHIP 22N0F +10% -10% 50.0V X7R 0603	
C272 C274	CZKII0391BC-R	CAP CHIP 390PF 50V X7R K 0603	
C173	CZKII0561BC-R	CAP CHIP 560P0F +10% -10% 50.0V X7R 0603	
C522	CZKII0821BC-R	CAP CHIP 820P0F +10% -10% 50.0V X7R 0603	
C287	H03-CEHEC02275E-R	CE 220UF +20% 10.0V P=5MM 85C SK 220/10V 5 X11	
C242 C291	H03-CEHIC01055E-R	CE 1UF +20% 50V D5XL11 P5MM 85C SK 1/50V 5 X11	
C603 C174 C175 C177 C178 C179 C192 C208 C259 C260 C364 C365 C366 C438 C447 C459 C463 C500 C537	CZZFI0104BF-R	CAP CHIP 100N0F +80% -20% 16.0V Y5V 0603	
C540	CZJII0820BE-R	CAPACITOR CERAMIC/CHIP .82pF 50V CH J NPO 0603	
C541	CZJII0121BE-R	CAP CHIP 120PF 50V J NPO 0603	
C542	CZDII0100BE-R	CAP CHIP 10PF 50V CH D NPO 0603	
C238	CZJII0470BE-R	CAP CHIP 47P0F +5% -5% 50.0V NPO 0603	
C602 C605	CZJII0330BE-R	CAP CHIP 33P0F +5% -5% 50.0V NPO 0603	
<i>Semiconductors</i>			
Q107 Q108 Q109	H03-TRKTA1267GR-R	KTA1267-GR TO-92M PNP	
Q100 Q102	H03-TRKTC3199GR-R	KTC3199-GR TO-92M NPN	
D110 D111 D601 D602 D604 D605 D606	H03-DS05GBUSCNB-R	DIODE PG05GBUSC	
IC49	H03-IC74LVC254D-R	IC SN74LVC257AD SOIC-16 Quadruple 2-Line To 1-Line Data Selector/Multiplexer With 3-State Outputs	
IC64	H03-ICAD1580BRT-R	IC AD1580BRTZ-REEL7 1.2 V Micropower, Precision Shunt Voltage Reference	
Q121 Q122	H03-TS2N7002LND-R	MOSFET N-CHANNEL 2N7002LT1G SOT-23	
D130 D131 D132 D133 D135 D136 D137 D138 D139 D140 D141 D142	H03-DS05GBUSCNB-R	DIODE PG05GBUSC	
D100 D101 D102 D103 D104 D105 D106 D107 D108 D109 D120 D121 D122 D123 D124 D125 D607	H03-DS1S50094NB-R	D-SLP 1SS355 35.0V 225MIOA	
D126 D127 D128	H03-DSBAV99LTNB-R	DIODE SWITCHING BAV99LT1G SOT-23	
D129	H03-DSUDZ09V1NB-R	D-ZENER UDZS 9.1B 9.1V 200MIOW	
IC30	H03-ICKIA7806I2-R	IC KIA7806AP VOLTAGE REGULATOR TO-220AB	
IC66	H03-IC74CB3T3D2-R	IC SN74CB3T3306DCTR SSOP-8 Dual Bus Switch Voltage Translator	
IC40	H03-ICADA44106A-R	IC ADA4410-6ACPZ Integrated Video Filter with Selectable Cutoff Frequencies for GBR, HD/SD, Y, C, and CVBS	
IC39	H03-ICADA44123A-R	IC ADA4412-3ARQZ Integrated Triple Video Filter with Selectable Cutoff Frequencies for RGB, HD and SD	
IC29	H03-ICADV7320KS-R	IC ADV7320LKSTZ 12-bit 216MHz Video Encoder with NSV and Macrovision® Copy Protection	
IC24	H03-ICADV7401EF-R	ADV7401BSTZ-110 LQFP100 10-Bit, Integrated, Multiformat SDTV/HDTV Video Decoder and RGB Graphics Digitizer	
IC12 IC42 IC45	H03-ICBU4053BB4-R	IC BU4053BCF SOP16 ANALOG MPX/DMPX	
IC18 IC19 IC20 IC21 IC22	H03-ICBU4094BD3-R	IC CMOS BU4094BCF SOP16 8-bit compatible shift / store register	
IC65	H03-ICIL1117J2-R	IC VOLTAGE REGULATOR IL1117-2.5 SOT-223	
IC11	H03-ICIL1117S33-R	IC LOW DROP REGULATOR IL1117-3.3 3.3V SOT-223 IK SEMICONDUCTOR	
IC43 IC46	H03-ICEEP24LCD2-R	24LC08BT-I/SNG SOIC-8P MICROCHIP 8K I2C Serial EEPROM	
IC60	H03-ICLM02068D2-R	IC-OPERAMP NJM2068M-TE1 DUAL OP-AMP SOP8	
IC25 IC26 IC33 IC34 IC35 IC36 IC37	H03-ICM1503XNRE-R	MM1503XNRE SOT-26B Video Switch 75 driver Y/C mix	
IC32	H03-ICMM1511XDL-R	IC-VIDEO SW MM1511XNRE SOT-26B Video Switch 75 driver Y/C mix	
IC13 IC14 IC15	H03-ICNJM2296D3-R	IC-LINEAR NJM2296M-TE1 5-INPUT 3-OUTPUT VIDEO SWITCH	
IC38	H03-ICNJM2586MN-R	IC VIDEO AMP NJM2586M-TE1 DMP24 WIDE BAND 3-INPUT 1-OUTPUT 3-CIRCUIT VIDEO AMPLIFIER	
IC55	H03-ICSII903144-R	IC HDMI RECEIVER SIL9031CTU TQFP144 Multi-Channel Audio Receiver Chipset	
IC54	H03-ICSIL903080-R	HDMI TRANSMITTER SII9030CTU TQFP80	

Ref. Designator	Part Number	Description	
VIDEO PCB			
IC23 IC28 IC31	H03-ICTSH95IDB4-R	IC-VIDEOPROC TSH95ID VIDEO AMPLIFIER	
Q119 Q120	H03-TS2N7002LND-R	MOSFET N-CHANNEL 2N7002LT1G SOT-23	
Q101	H03-TRKTC3875ND-R	TRANSISTOR NPN KTC3875S SOT23	
Q110 Q111 Q112	H03-TSKRA107SNI-R	KRA107S SOT-23 PNP	
Q103 Q104 Q105 Q106 Q113 Q114 Q115 Q118	H03-TSKRC107SND-R	KRC107S SOT-23 NPN	
IC41 IC44 IC58	H03-TSUPA672TNH-R	TRANSISTOR MOSFET N-CHANNEL UPA672T-T1-A SMD	
IC56 IC57 IC61 IC62	H03-DSAMP0514MN-R	DIODE TVS ARRAY RCLAMP0514M MSOP-10L	
IC10	H03-ICIL1117SDG-R	IC LOW DROP REGULATOR IL1117S-1.8 1.8V SOT-223	
D608	H03-DSKDZ3V30NB-R	DIODE ZENER,KDZ3.3EV KEC	
IC27	H03-ICLC74763ME-R	LC74763M-9602-E SOP30 On-Screen Display LSI	
<i>Resistors</i>			
R191 R192 R618 R619	RS1AD0750NA-R	RES CHIP 75OHM 1% 1/16W 0603	
R153	RS1AD1691NA-R	RES CHIP 1K69 ohm 1/16W 1% 0603	
R288 R291 R294 R298 R301 R302 R304 R357 R602 R603	RS3AD0000NA-R	RES CHIP, 0 R 1/16W +/-5%, 0603	
R358 R359	RS3AD0101NA-R	RES CHIP,100R 1/16W +/-5%,0603	
R251 R255 R258 R371	RS3AD0102NA-R	RES CHIP,1K 1/16W +/-5% ,0603	
R164 R223 R224 R225	RS3AD0103NA-R	RES CHIP,10K 1/16W +/-5% ,0603	
R173 R174 R334	RS3AD0105NA-R	RES CHIP 1M 1/16W +5% 0603	
R230 R231	RS3AD010ANA-R	RES CHIP,1R 1/16W +/-5%,0603	
R126	RS3AD0123NA-R	RES CHIP,12K 1/16W +/-5%,0603	
R165	RS3AD0152NA-R	RES CHIP 1K5 1/16W +5% 0603	
R252 R253 R256 R259	RS3AD0153NA-R	RES CHIP,15K 1/16W,+/-5%,0603.	
R339	RS3AD0201NA-R	RES.CHIP,200 1/16W +-5%,0603.	
R261 R263	RS3AD0222NA-R	RMGCFMIC 2K2 OHM +5% 0603	
R151 R152	RS3AD0272NA-R	RMGCFMIC 2K7 OHM +5% 0603	
R368	RS3AD0302NA-R	RMGCFMIC 3K0 OHM +5% 0603	
R335	RS3AD0330NA-R	RMGCFMIC 33R0 OHM +5% 0603	
R260 R262	RS3AD0333NA-R	RMGCFMIC 33K0 OHM +5% 0603	
R369	RS3AD0390NA-R	RES,CHIP 39 OHM 1/16W +/-5% 0603	
R206 R336	RS3AD0470NA-R	RMGCFMIC 47R0 OHM +5% 0603	
R208 R282 R283 R333 R345 R346 R381 R382	RS3AD0472NA-R	RES CHIP,4K7 1/16W +/-5%,0603	
R247 R250	RS3AD0680NA-R	RMGCFMIC 68R0 OHM +5% 0603	
R370	RS3AD0681NA-R	RES CHIP,680R 1/16W +/-5%,0603	
R163	RS3AD0682NA-R	RMGCFMIC 6K8 OHM +5% 0603	
R254 R257	RS3AD0752NA-R	RES CHIP 7.5K,1/16W,+5%,0603.	
R186	RS3AD0301NA-R	RES,CHIP 300 OHM 1/16W +/-5% 0603	
R400 R401 R402 R403	RS3AD0473NA-R	RES CHIP,47K 1/16W +/-5%,0603	
R478	RS1AD0101NA-R	RES CHIP 100 OHM 1/16W 1% 0603	
R500	RS3AD0682NA-R	RMGCFMIC 6K8 OHM +5% 0603	
RV16 RV17 RV18 RV19 RV20 RV21 RV22 RV23	H03-VR0402V275R-R	VARISTOR CHIP CT0402V275RFG 16V	
RV10 RV11 RV12 RV13 RV14 RV15	H03-VR0603V150R-R	VARISTOR CHIP CT0603V150RFG	
R100 R101 R102 R103 R105 R106 R107 R108 R109 R110 R111 R189 R190 R210 R217 R218 R219 R233 R234 R237 R238 R239 R240 R241 R242 R243 R244 R245 R246 R267 R268 R269 R270 R271 R272 R273 R274 R275 R277 R278 R279 R383 R384 R385 R386 R387 R388 R617	RS1AD0750NA-R	RES CHIP 75OHM 1% 1/16W 0603	
R332	RS1AD4750NA-R	RES.CHIP 475 OHM 1/16W +/-1% 0603	
R601	RS1AD5493NA-R	RES,CHIP 549K 1/16W +/-1% 0603	
R104 R209 R211 R232 R236	RS1AD787ANA-R	RES CHIP 78.7 ohm 1/16W 1% 0603	
R286 R292 R296 R355 R475	RS3AD0000NA-R	RES CHIP, 0 R 1/16W +/-5%, 0603	
R168 R177 R178 R179 R180 R330 R331 R340 R341 R378 R379	RS3AD0101NA-R	RES CHIP,100R 1/16W +/-5%,0603	

Ref. Designator	Part Number	Description
VIDEO PCB		
R123 R124 R125 R127 R128 R129 R131 R132 R133 R135 R136 R137 R139 R140 R141 R160 R161 R170 R171 R172 R347 R351	RS3AD0102NA-R	RES CHIP,1K 1/16W +/-5% ,0603
R144 R145 R146 R159 R169 R212 R213 R214 R220 R221 R222 R311 R312 R313 R342 R349 R350 R353 R354 R360 R361 R606 R610 R611	RS3AD0103NA-R	RES CHIP,10K 1/16W +/-5% ,0603
R615	RS3AD0104NA-R	RES CHIP,100K 1/16W +/-5% ,0603
R154 R155	RS3AD0105NA-R	RES CHIP 1M 1/16W +5% 0603
R112 R113 R114 R115 R116 R117 R118 R119 R147 R148 R157 R158 R184 R185 R215 R216 R227 R228 R229 R264 R265 R266 R276 R389 R390	RS3AD010ANA-R	RES CHIP,1R 1/16W +/-5%,0603
R162 R187 R188 R226	RS3AD0121NA-R	RMGCFMIC 120R0 OHM +5% 0603
R130 R134 R138 R142	RS3AD0123NA-R	RES CHIP,12K 1/16W +/-5%,0603
R167 R612	RS3AD0124NA-R	RES CHIP,120K 1/16W +/-5%,0603
R474	RS3AD0150NA-R	RES,CHIP 15 OHM +/-5%,1/16W, 0603
R150	RS3AD0154NA-R	RMGCFMIC 150K0 OHM +5% 0603
R343 R344	RS3AD0182NA-R	RES CHIP,1.8K,1/16W,+5%,0603.
R248	RS3AD0222NA-R	RMGCFMIC 2K2 OHM +5% 0603
R348 R352 R607 R608	RS3AD0223NA-R	RES CHIP,22K 1/16W +/-5%,0603
R166 R609	RS3AD0224NA-R	RES CHIP,220K 1/16W +/-5%,0603
R149	RS3AD0271NA-R	RMGCFMIC 270R0 OHM +5% 0603
R365	RS3AD0302NA-R	RMGCFMIC 3K0 OHM +5% 0603
R249	RS3AD0333NA-R	RMGCFMIC 33K0 OHM +5% 0603
R367	RS3AD0390NA-R	RES,CHIP 39 OHM 1/16W +/-5% 0603
R181 R182 R183 R207 R362 R380 R614	RS3AD0470NA-R	RMGCFMIC 47R0 OHM +5% 0603
R120	RS3AD0471NA-R	RMGCFMIC 470R0 OHM +5% 0603
R175 R176 R280 R281 R284 R285 R337 R338 R364	RS3AD0472NA-R	RES CHIP,4K7 1/16W +/-5%,0603
R604 R605 R613	RS3AD0473NA-R	RES CHIP,47K 1/16W +/-5%,0603
R156	RS3AD0624NA-R	RES,CHIP 620K 1/16W +/-5% 0603
R235	RS3AD0820NA-R	RMGCFMIC 82R0 OHM +5% 0603
R143	RS3AD0822NA-R	RMGCFMIC 8K2 OHM +5% 0603
RA10 RA11 RA12 RA13 RA16 RA17 RA18 RA19 RA22 RA33 RA34 RA35 RA36 RA39	RS3AY0470NA-R	RES NETWORK RCA 47R0 OHM +5% 62M15W CN34JT470
RA30 RA31 RA32	RN3AY0220NA-R	RES NETWORK RCA 22OHM 1/16W 5% CN34JT220
R372 R373 R374 R375 R376 R377	RS1AD3000NA-R	RES.CHIP 300R 1/16W +/-1% 0603
R473	RS1AD049ANA-R	RES.CHIP 4.99OHM 1/16W +/-1% 0603
R476 R477	RS1AD301ANA-R	RES.CHIP 30.1R 1/16W +/-1% 0603
R121	RS3AD024ANA-R	RESISTOR CHIP 2R4 OHM 1/16W 5% 0603
<i>Miscellaneous</i>		
Y100	H03-OSXBE14M39S-R	CRYSTAL 14.31818MHZ HC-49/S WOOIN
Y101	H03-OSXBE17M79S-R	CRYSTAL 17.734475MHZ HC-49/S WOOIN
Y104	H03-OSXBE28M39S-R	CRYSTAL 28.322MHZ 18pF HC-49/S
K100 K101 K102 K103	H03-RLL0517811A-R	RELAY D3009(1-1462033-4)
NJ16	H03-SOR12BJ12NN-R	JACK RCA 12P BJ120154JN
NJ10 NJ11	H03-SORA60031YN-R	JACK RCA+S-VIDEO 6P C8030031YN
P602	H03-WN04AB00000-R	CONN 2.0MM GIL-S-04P-S2L2-EF 4P
P700 P701	H03-WN04AB100WH-R	CONN WAFER 2.0MM 4P 35237-0410 WHT
N700 N701	H03-WN04SB100WH-R	CONN WAFER 2.0MM 4P 35336-0410 WHT
P601	H03-WN06AB00000-R	CONNECT 2.0mm 6P GIL-S-6P-S2L2-EF
N608 P702	H03-WN10AB000WH-R	CONNECT WAFER 2.0mm 10P 35237-1010 WHT

Ref. Designator	Part Number	Description	
VIDEO PCB			
N702	H03-WN10SB100WH-R	CONNECT WAFER 2.0mm 10P 35336-1010 WHT	
P605	H03-WN29AI00000-R	CONN 1.25MM 29 FE R WH GF120-29S-LS 2794 A6	
BK10	H03-ZMD27S05A00-R	BKT IPOD	
N611	H03-WN16AI00000-R	CONNECT 1.25MM 16P GF120-16S-LS 1.25MM 16P	
P603	H03-WN07AD00000-R	CONNECT WAFER 2.5MM 7P 5268-07A WHT ANGLE	
P612	H03-WN14AI00000-R	CONNECT 1.25mm 14P,GF120-14S-LS 1.25mm 14P	
N607	H03-WN05SB26000-R	WIRE ASS'Y,UL1533/2547#26(TA) 260mm 2.0mm 5P GRY	
P604	H03-WN05AB00000-R	GIL-S-05P-S2L2-EF 5P	
L101 L102 L103 L121	H03-FB05B3580NN-R	BEAD AXIAL/TAP,HC3580 80.5ohm	
L122	H03-LAINB0470CR-R	LF 47U0H +10% 5.8 OHM 500MIOA	
L109	H03-LALNB056ACR-R	INDUCTOR COIL AL02TB5R6J 5.6UH 1.9OHM +5%	
L100 L130 L131 L132 L133 L134 L135 L136 L137 L138 L139 L140 L141 L146	H03-FB1212012KF-R	FCM2012KF-121T08 120ohm 2012	
L110 L112	H03-FB2012F1R5K-R	FCI2012F-1R5K 1.5UH 0805	
L105 L106 L107 L108 L114 L115 L116 L118 L119 L120 L154	H03-FB2012F3R9K-R	FCI2012F-3R9K 3.9UH 0805	
L111 L113	H03-LS2012F1R8K-R	INDUCTOR COIL FCI2012F-1R8K 1.8UH 0805	
L142 L143 L144 L145	H03-LS2012H9002-R	CHOKE COIL ACM2012H-900-2P	
NJ60	H03-SO1R018H91E-R	DA1R018H91E	
NJ17 NJ18 NJ19	H03-SOYKF457009-R	JACK HDMI YKF45-7009 JALCO	
F100	H03-SWNANDC1502-R	SWITCH POLY NANOSMDC150F-2 SMD	
Y103	H03-OSX27MSCOB0-R	CRYSTAL,27.000MHz SCO-103 25-27.000M	
MECHANICAL ASSEMBLY			
	H03-TXPWMEI95B0-R	SW PUSH POWER SDDL15700	
	H03-TXPWMEI95B0-R	POWER TRANSFORMER AVR645 MAIN TRANS 120V 60Hz	US
	H03-TXPWMEI93B0-R	POWER TRANSFORMER AVR645 MAIN TRANS 230V 50Hz	EU
	H03-WF22S2605RT-R	DHCDT-22/260-P1.25-RT(5/5,10/10)	
	H03-WG02SG8532A-R	WIRECONASY UNIQUE 2P 530MM UL1617 PVC DBL INSULATED	
	H03-WG04SB81400-R	UL1007#26 STR 140mm 2.0mm 4P WHT	
	H03-WN29SI02000-R	WIRE FFC(CARD CABLE) DHCDT-29/200-P1.25-ST(5/5,10/10)	
	H03-ZMB01S00100-R	BKT HEADPHONE	
	H03-ZMB01S02200-R	SPRING PLATE GND C5212 0.2T	
	H03-ZMC11S00200-R	AL DOOR AVR	
	H03-ZMC11S04B00-R	BKT FRAME GUIDE	
	H03-ZMC11S06A00-R	SPRING STOPPER AVR	
	H03-ZMC11S07A00-R	CHASSIS FRONT AVR	
	H03-ZMC11S09A00-R	BKT FAN FRONT AVR	
	H03-ZMC11S10A00-R	BKT FAN REAR AVR	
	H03-ZMC11S12A00-R	CAP BUTTON STAND-BY AVR	
	H03-ZMC11S14A00-R	BRACKET DOOR	
	H03-ZMC12S07A00-R	COVER BOTTOM	
	H03-ZMC12S08B00-R	BKT TRANS BOTTOM	
	H03-ZMC12S09A00-R	BKT HEATSINK	
	H03-ZMC12S19A00-R	BKT AC INLET	
	H03-ZMD05S16A00-R	BKT HINGE AVR7300	
	H03-ZMD2701ZANI-R	BRACKET POSISTOR,METAL,AVR	
	H03-ZMD2702GAGY-R	AL PANEL FRONT,AVR	
	H03-ZMD2703GAGY-R	BADGE FRONT,AL,AVR,GREY,HOT STAMPING	
	H03-ZMD27HS0100-R	H/SINK AMP AVR	
	H03-ZMD27HS0200-R	H/SINK MAIN AVR	
	H03-ZMD27HS0300-R	HEATSINK AMP SMALL	
	H03-ZMD27S04A00-R	BKT FRAME GUIDE AVR	
	H03-ZMD27S06A00-R	BKT VIDEO	
	H03-ZMD27S08A00-R	COVER TOP AVR	
	H03-ZMD27S13A00-R	CHASSIS MAIN AVR	
	H03-ZMD27S20A00-R	BADGE harman/kardon COVER TOP AVR	
	H03-ZMD29S02A00-R	PANEL REAR AVR645US	
	H03-ZPC1004GASG-R	BUTTON 7 KEY	
	H03-ZPC1018GART-R	FILTER VFD	

Ref. Designator	Part Number	Description	
MECHANICAL ASSEMBLY			
	H03-ZPD0315GAMW-R	VOLUMN KNOB	
	H03-ZPD0316GASG-R	COVER KNOB	
	H03-ZPD0317GACR-R	CAP KNOB VOLUMN	
	H03-ZPD2919GABT-R	WINDOW DISPLAY AVR645+BADGE NAME AVR645	
	H03-ZVC11DWT100-R	TAPE DOOR	
	H03-ZVC11DWT200-R	TAPE PANEL	
	H03-ZVC11GEAR01-R	DAMPER GEAR DP120	
	H03-ZVC11TUNE01-R	TUNER MODULE KST-MB011MW0-81 US	US
	H03-ZVD01TUNE00-R	TUNER MODULE KST-MB114MW1-81 OEM EU	EU
	H03-ZVJF0925S00-R	DC FAN JF0925S1M-003C651R 12V 92x92x25mm	
	ZFD122062SB-R	RUBBER TOP AVR635	
	ZFD122072SB-R	RUBBER TOP AVR635	
	ZFNR13830SB-R	RUBBER SIDE	
	ZFNR19720SB-R	RUBBER FOOT 19.7X19.7X2T BK	
	ZMC12S13AYE-R	STANDOFF HEX M4X0.7 6X31.9H	
	ZMC12S14AYE-R	STANDOFF HEX M4X0.7 6X61.9H	
	ZNSSM4045HZ-R	NUT M4 HEXAGON CIRCULAR EXTERNAL	
	ZPC1002GAGY-R	DOOR AVR	
	ZPC1003GAGY-R	BUTTON POWER	
	ZPC1005GAGY-R	BUTTON 8 KEY	
	ZPC1006GAWH-R	BUTTON STANDBY	
	ZPC1007GAMW-R	INDICATOR STAND-BY	
	ZPC1017GABK-R	HOLDER VFD AVR	
	ZPC1102GAMW-R	INDICATOR VIDEO	
	ZPC1103GAGY-R	FOOT 50MM 15.8MM	
	ZPD2701GAGY-R	PANEL FRONT AVR745	
	ZSMCM4008BY-R	SCREW BM 4X8	
	ZSMCM4010BB-R	SCREW BM 4X10	
	ZSMPM3006LB-R	SCREW.M.S.M3X6 P/HD BLACK	
	ZSTBM3008BY-R	SCREW ST BH 3X8	
	ZSTBM3010BB-R	SCREW ST BH 3X10	
	ZSTBM3012BY-R	SCREW ST BH 3X12 PIVOT	
	ZSTGM3010BB-R	SCREW ST BH 3X10 GROUND	
	ZSTWM3006BB-R	SCREW ST WPH 3X6	
	ZSTWM3008BY-R	SCREW ST WPH 3X8	
	ZSTWM3A08BY-R	SCREW ST W7.5PH 3X8	
	ZSTWM4008BC-R	SCREW ST WPH 4X8 SILVER CHROM	
	ZUC1201AABK-R	SPONGE 30X30X10T BK	
	ZWF793008PO-R	WASHER FIBER 3 0.8T	
	ZWM623108SZ-R	WASHER SPRING 3	
	ZWM763109SZ-R	AC SPRING WASHER RT2250(PAV5005)	
	ZWM803305PZ-R	WASHER PLAIN 3	
	ZWMC04810PZ-R	WASHER PLAIN 4	
	H03-WF16S0700ST-R	WIRE FFC CABLE DHCDT-16/70-P1.25-ST(5/5,10/10)	
	H03-WF14S1705ST-R	WIRE FFC CABLE DHCDT-14/170-P1.25-ST(5/5,10/10)	
	H03-WG09SB82000-R	WIRE ASS'Y UL1007#26(TA) 200mm 2.0mm 9P WHT	
	H03-FBD0480BR00-R	FCORE CLAMP FILTER LF80BR W5 SRH 16X28X9	
	H03-ZUD0301ABBK-R	SPONGE-UL 30X30X12T BK	
	H03-ZMD27S07A00-R	SHIELD AL	
	ZSTBM3014BY-R	SCREW ST BH 3X14 PIVOT	
	ZFNR19730SB-R	RUBBER FOOT 19.7X19.7X3.0T BK	
TUNER MODULE USA ONLY	H03-ZVC11TUNE01-R	TUNER MODULE KST-MB011MW0-81 USA ONLY	
TUNER MODULE EUROPE	H03-ZVD01TUNE00-R	TUNER MODULE KST-MB114MW1-81 OEM EUROPE ONLY	

SCHEMATIC DIAGRAM AVR745 PROCESSOR(1/2)
harman kardon PROCESSOR B'D

REVISION RECORD		
No.	Date	Contents

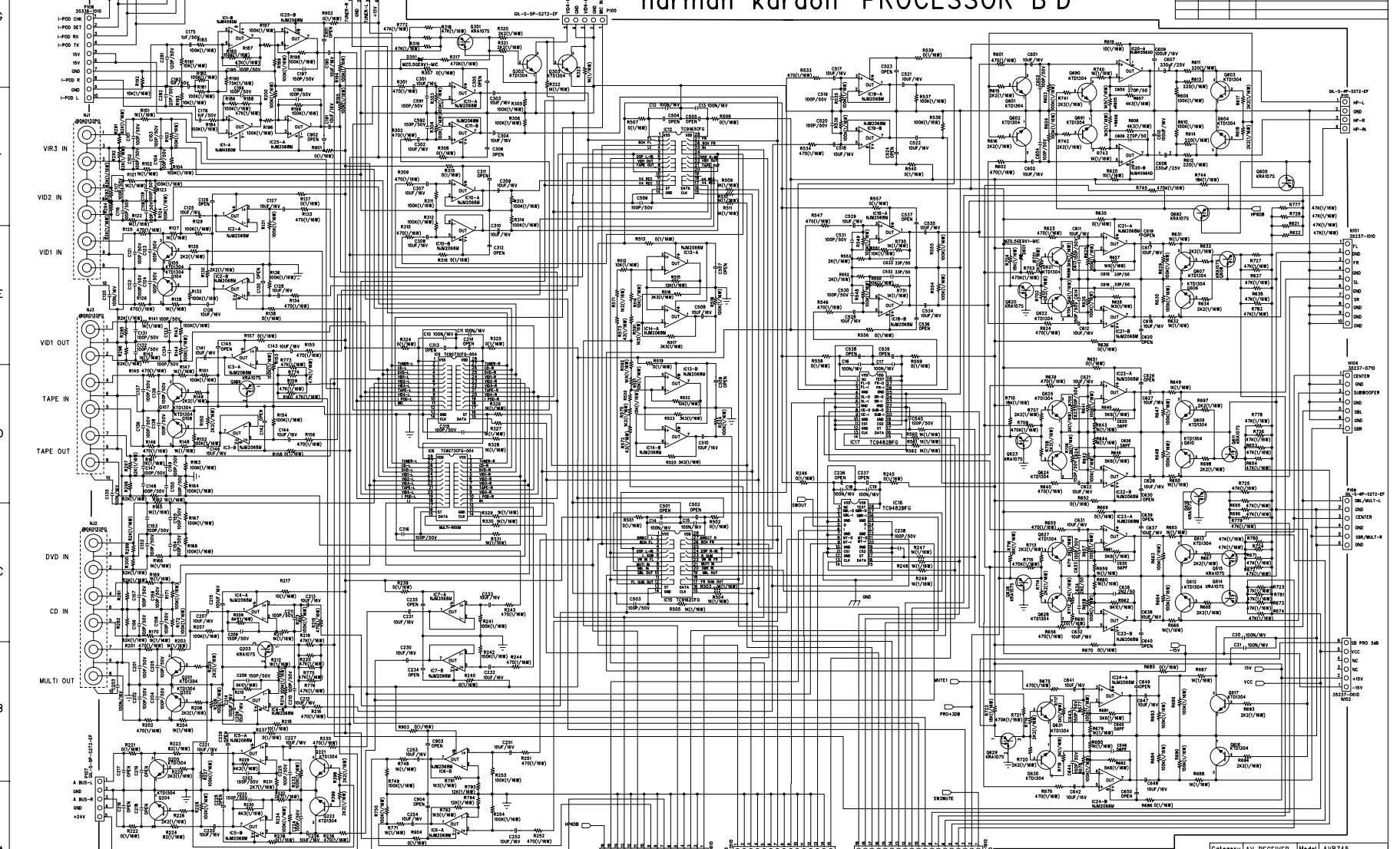

Category	AV RECEIVER	Model	AVR745
Sheet	1	2	PROCESSOR
Draw	Approved	Date	Drawing No
J.S.CHOI		16 May 2006	

REVISION RECORD		
NO.	Date	Contents

SCHEMATIC DIAGRAM AVR745 PROCESSOR (2/2)
 harman kardon PROCESSOR B'D

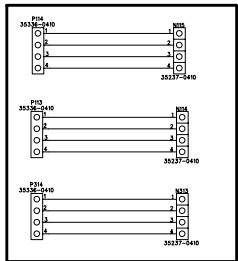
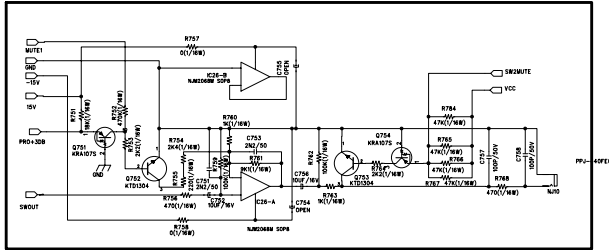

Category	AV RECEIVER	Model	AVR745
Stage	Ver.	Sheet	B'D name
MP		2 / 2	PROCESSOR
Draw	Approved	Date	Drawing No
J.S.CHOI		16.May.2006	

AVR645

SCHEMATIC DIAGRAM AVR645-US SUPPLY & RS232
harman kardon

harman/kardon

REVISION RECORD		
NO.	Date	Contents

G
F
E
D
C
B
A

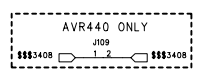
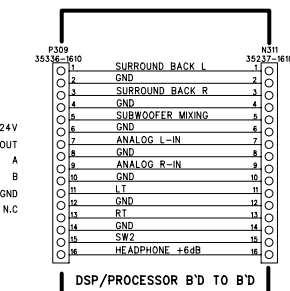
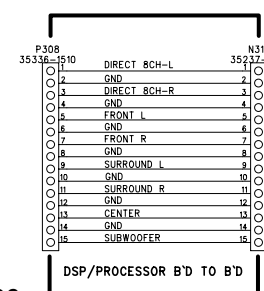
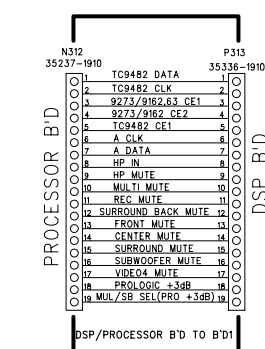
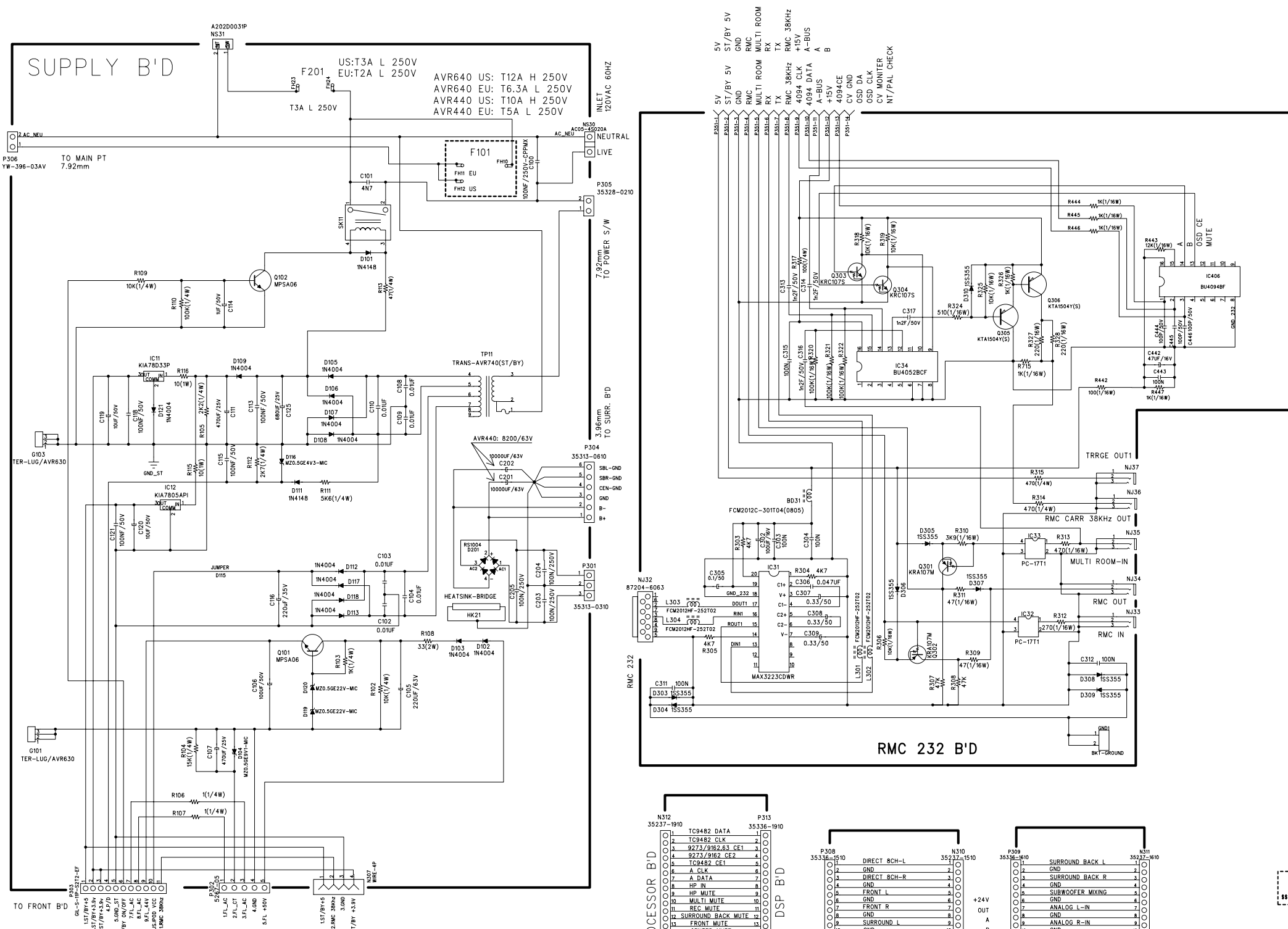

Category	A/V RECEIVER	Model	AVR645-US
Stage	Ver.	Sheet	B'D name
FTMS		1 / 1	SUPP/REGU
Draw	Approved	Date	Drawing No
S.Y. KIM		04.May.2006	

Schematic Diagram

HARMAN KARDON AVR645 VIDEO

REVISION RECORD		
NO.	Date	Contents

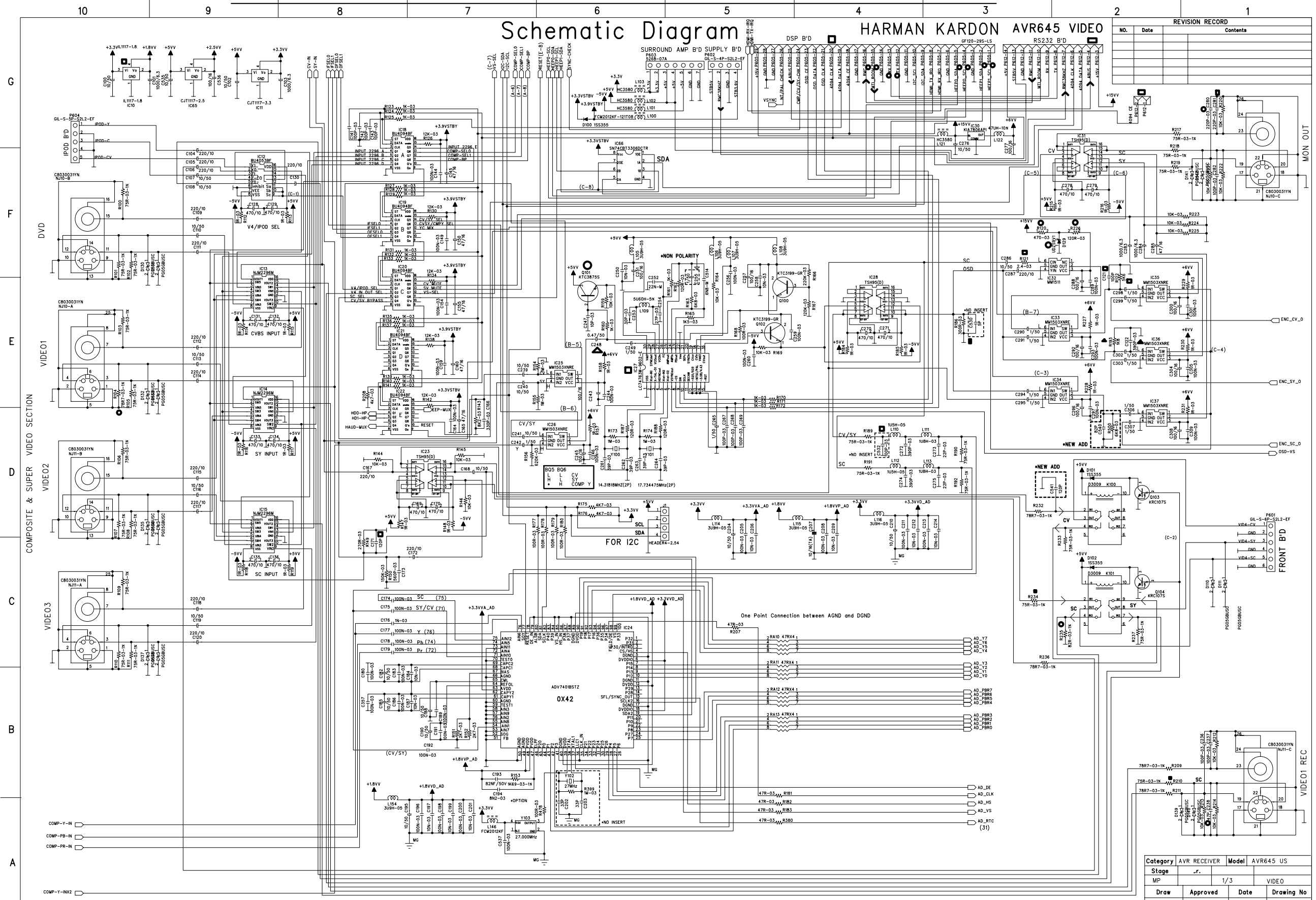

Category	AVR RECEIVER	Model	AVR645 US
Stage	.		
MP		1/3	VIDEO
Draw	Approved	Date	JUN.13.06.
Drawn	GEUM.J.G		

Schematic Diagram

HARMAN KARDON AVR645 VIDEO

REVISION RECORD		
NO.	Date	Contents

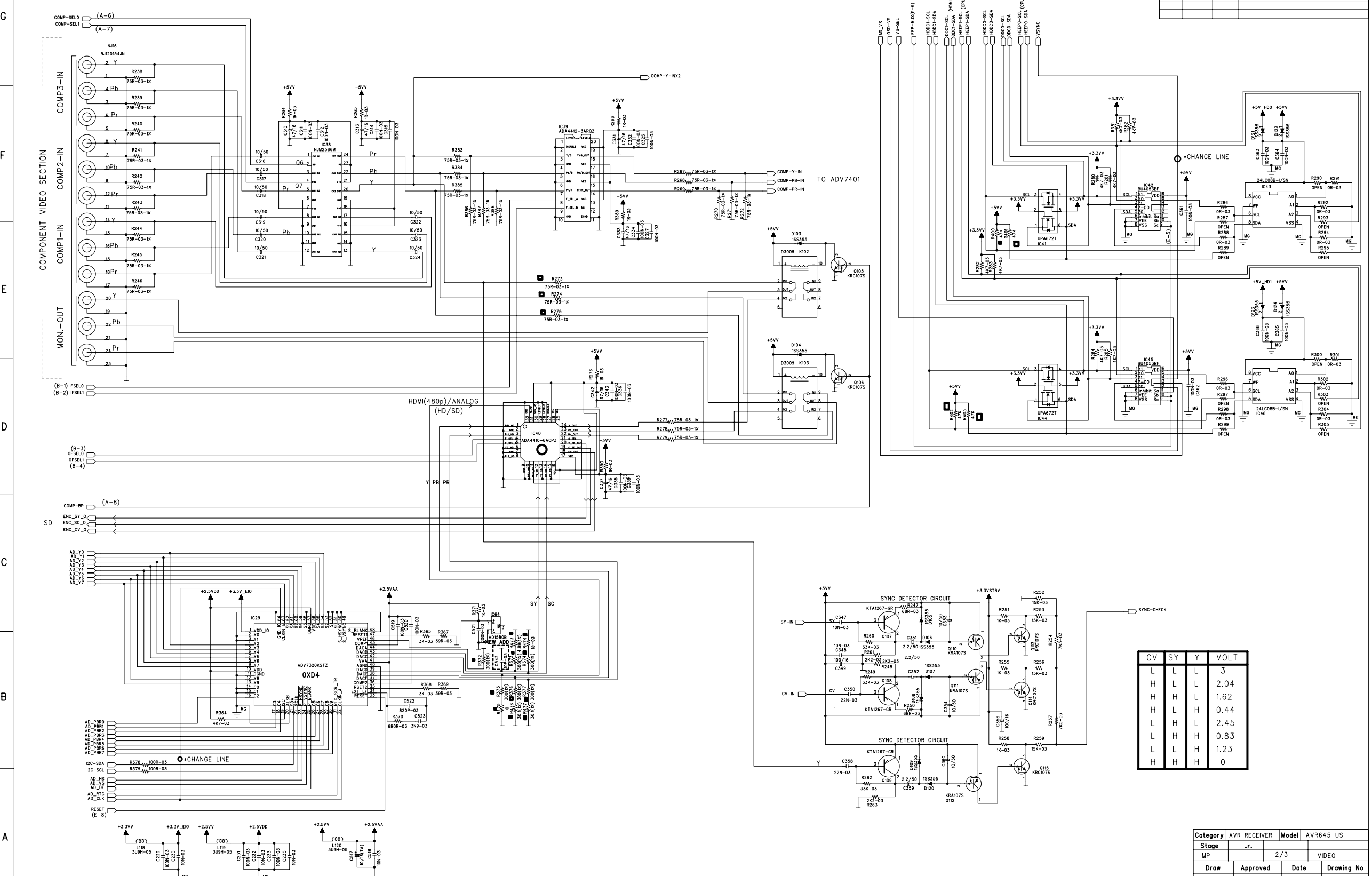

CV	SY	Y	VOLT
L	L	L	3
H	L	L	2.04
H	H	L	1.62
H	L	H	0.44
L	L	H	2.45
L	H	H	0.83
H	H	H	1.23

Category	AVR RECEIVER	Model	AVR645 US
Stage	.r.		
MP		2/3	VIDEO
Draw	Approved	Date	Drawing No
GEUM.J.G		JUN.13.06.	

Schematic Diagram

HARMAN KARDON
AVR645 VIDEO

REVISION RECORD		
NO.	Date	Contents

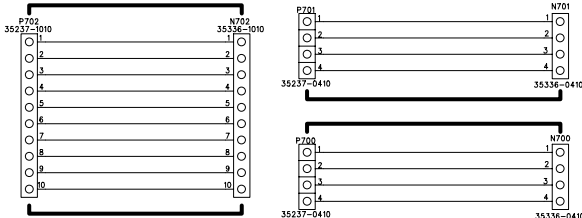
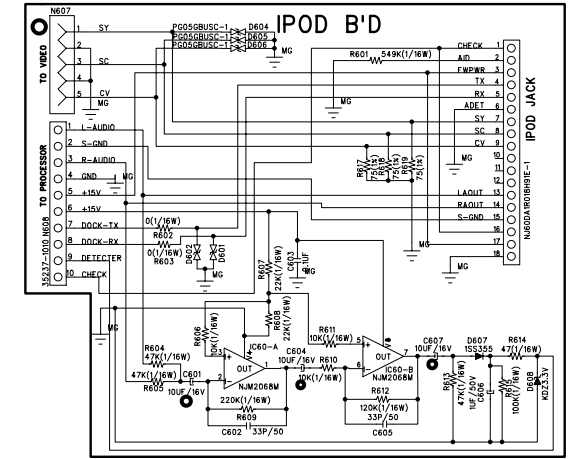
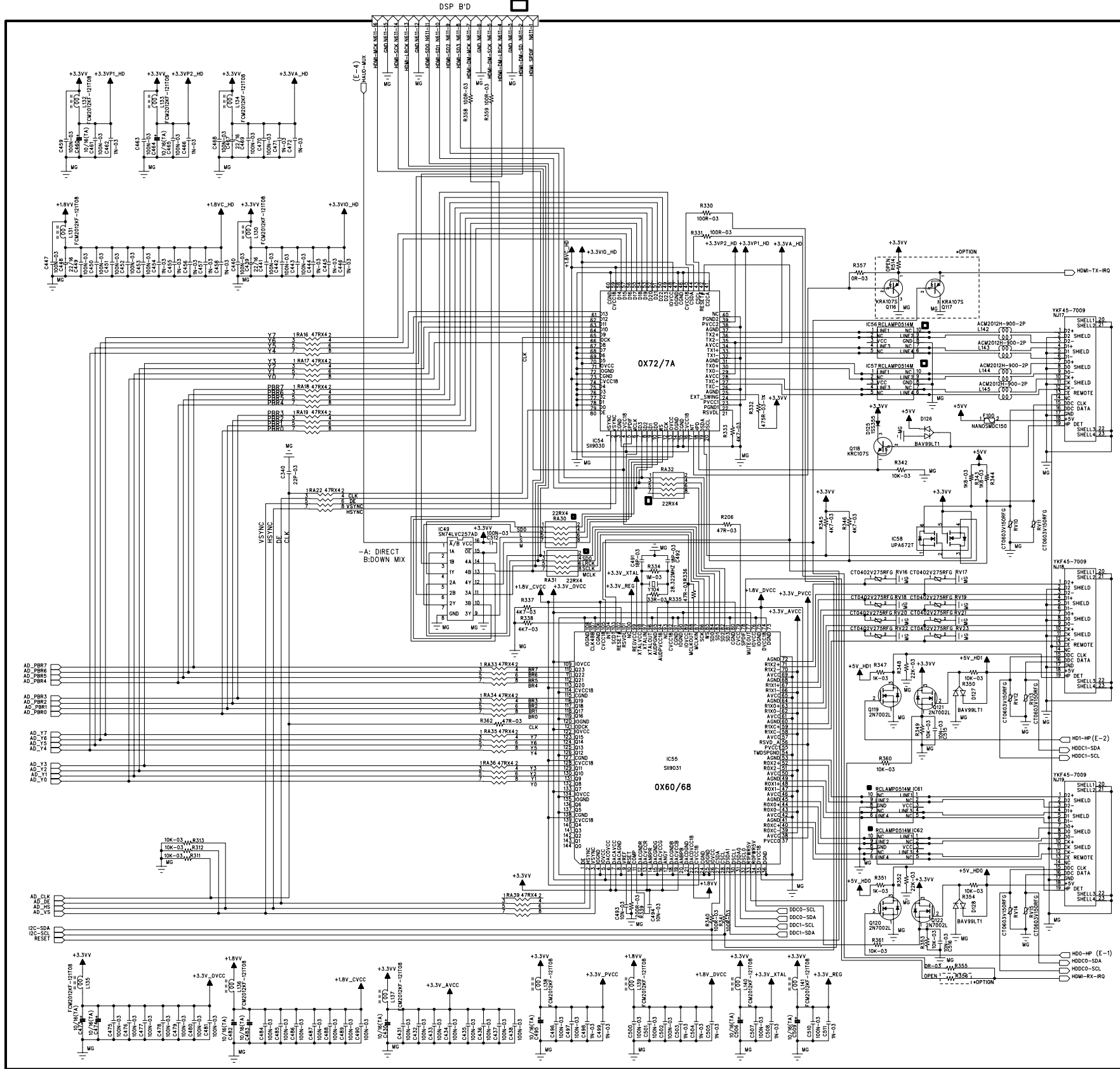

Category	AVR RECEIVER	Model	AVR645 US
Stage	-		
MP		3/3	VIDEO
Draw	Approved	Date	Drawing No
GEUM,J.G		JUN.13.06.	

SCHEMATIC DIAGRAM

harman/kardon
AVR745 FRONT

REVISION RECORD		
NO.	Date	Contents

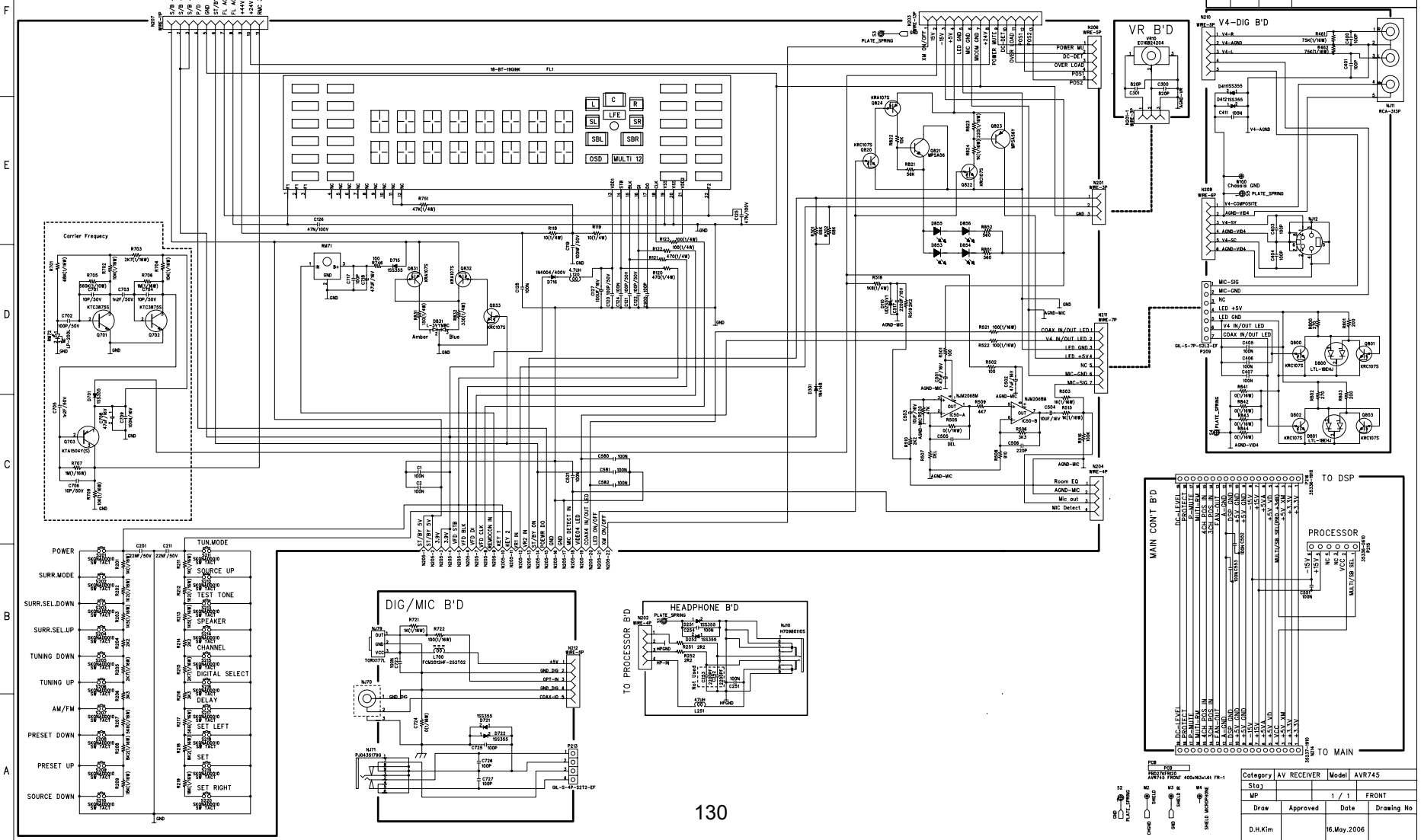

F
F
D
C
B
A

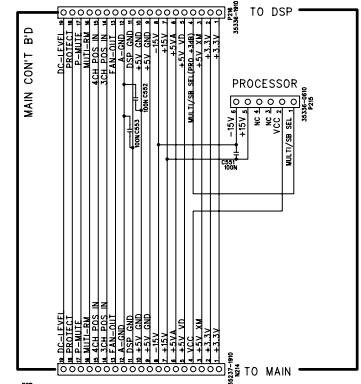
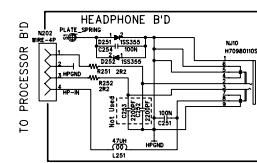
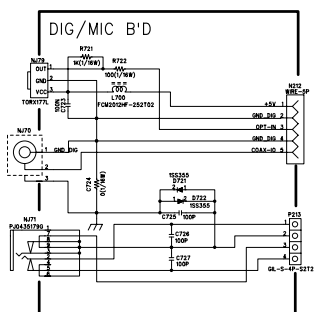
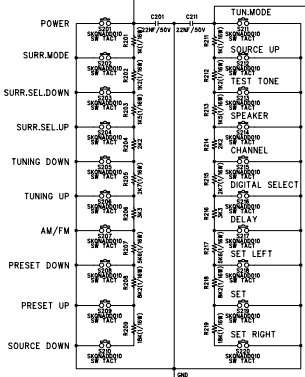

Category	AV RECEIVER	Model	AVR745
MP	1	1	FRONT
Draw	Approved	Date	Drawing No.
D.H.Kim		16.May.2006	

AVR645

AVR440 ONLY

harman/kardon

NO.	Date	Contents
1		
2		
3		
4		
5		
6		
7		
8		
9		
10		

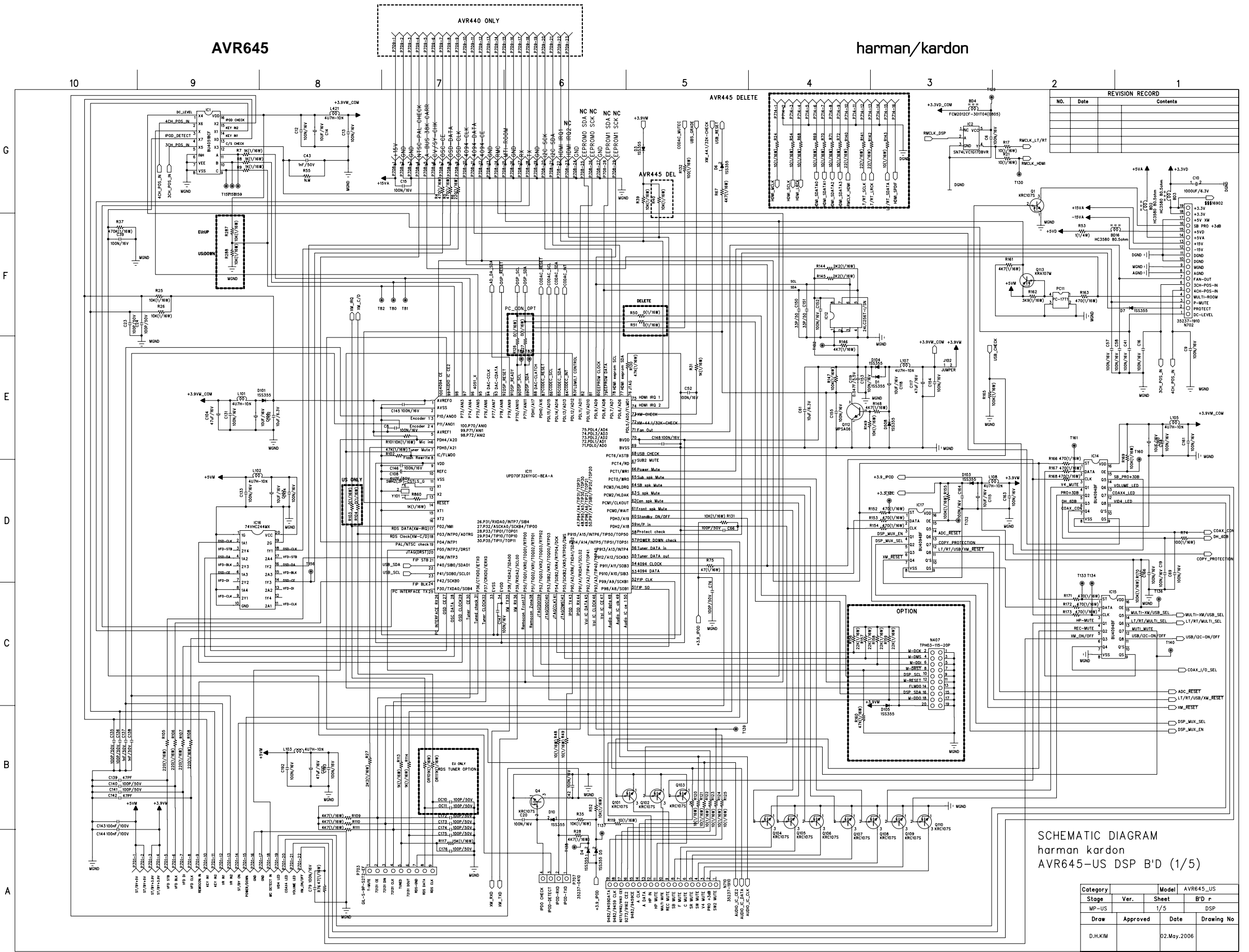

SCHEMATIC DIAGRAM harman kardon AVR645-US DSP B'D (1/5)

Category	Model	AVR645-US
Stage	Ver.	Sheet
MP-US	1/5	DSP
Draw	Approved	Date
D.H.KIM		02.May.2006
		Drawing No

REVISION RECORD		
NO.	Date	Contents

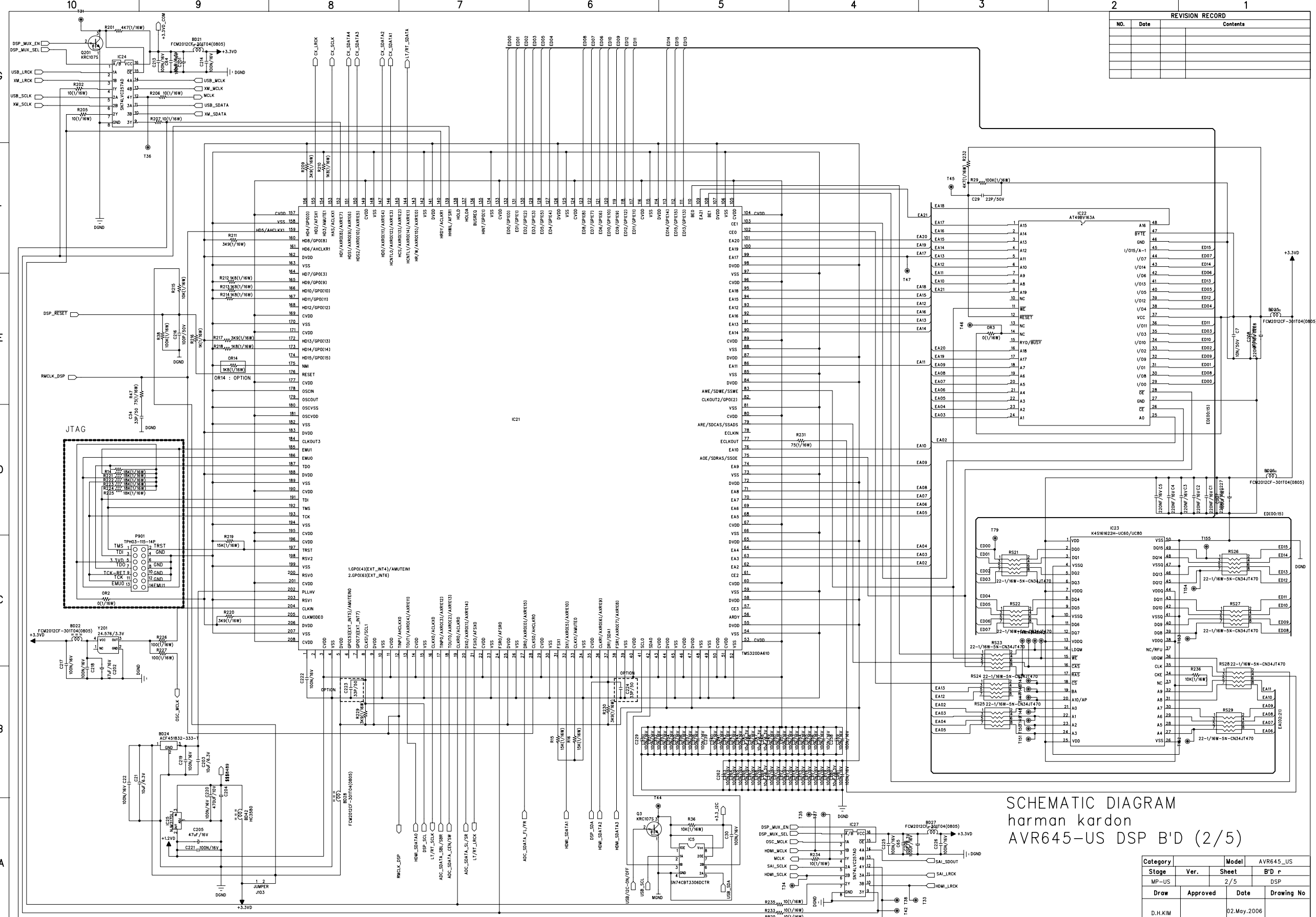

SCHEMATIC DIAGRAM
harman kardon
AVR645-US DSP B'D (2/5)

Category	Model	AVR645-US
Stage	Ver.	B'D r
MP-US	Sheet	2/5
Draw	Approved	Date
D.H.KIM		02.May.2006
		Drawing No

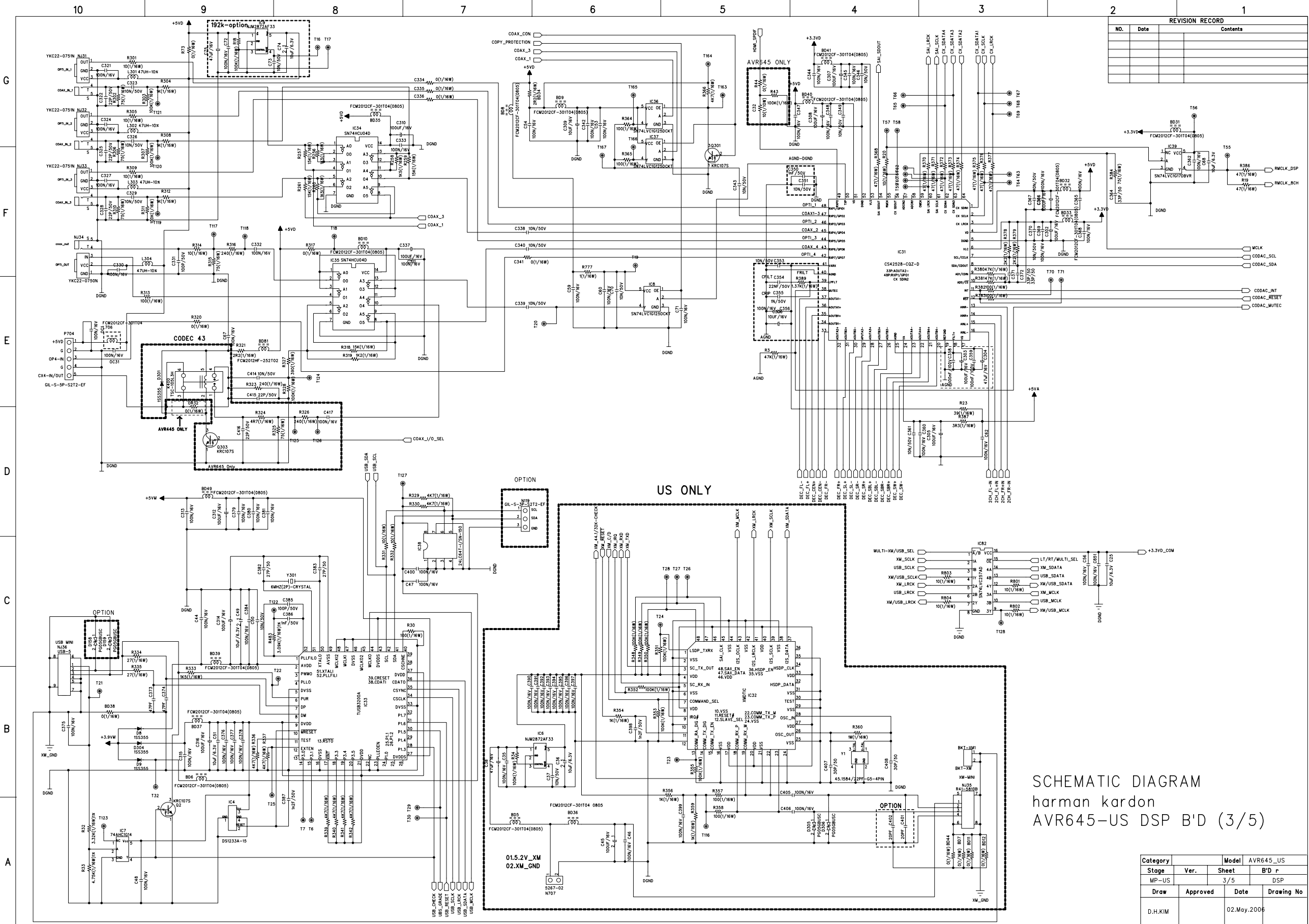

REVISION RECORD		
NO.	Date	Contents

SCHEMATIC DIAGRAM
harman kardon
AVR645-US DSP B'D (3/5)

Category	Model	AVR645_US	
Stage	Ver.	Sheet	B'D r
MP-Us		3/5	DSP
Draw	Approved	Date	Drawing No
D.H.KIM		02.May.2006	

10

9

8

7

6

5

4

3

2

1

REVISION RECORD		
NO.	Date	Contents

G

F

E

D

C

B

A

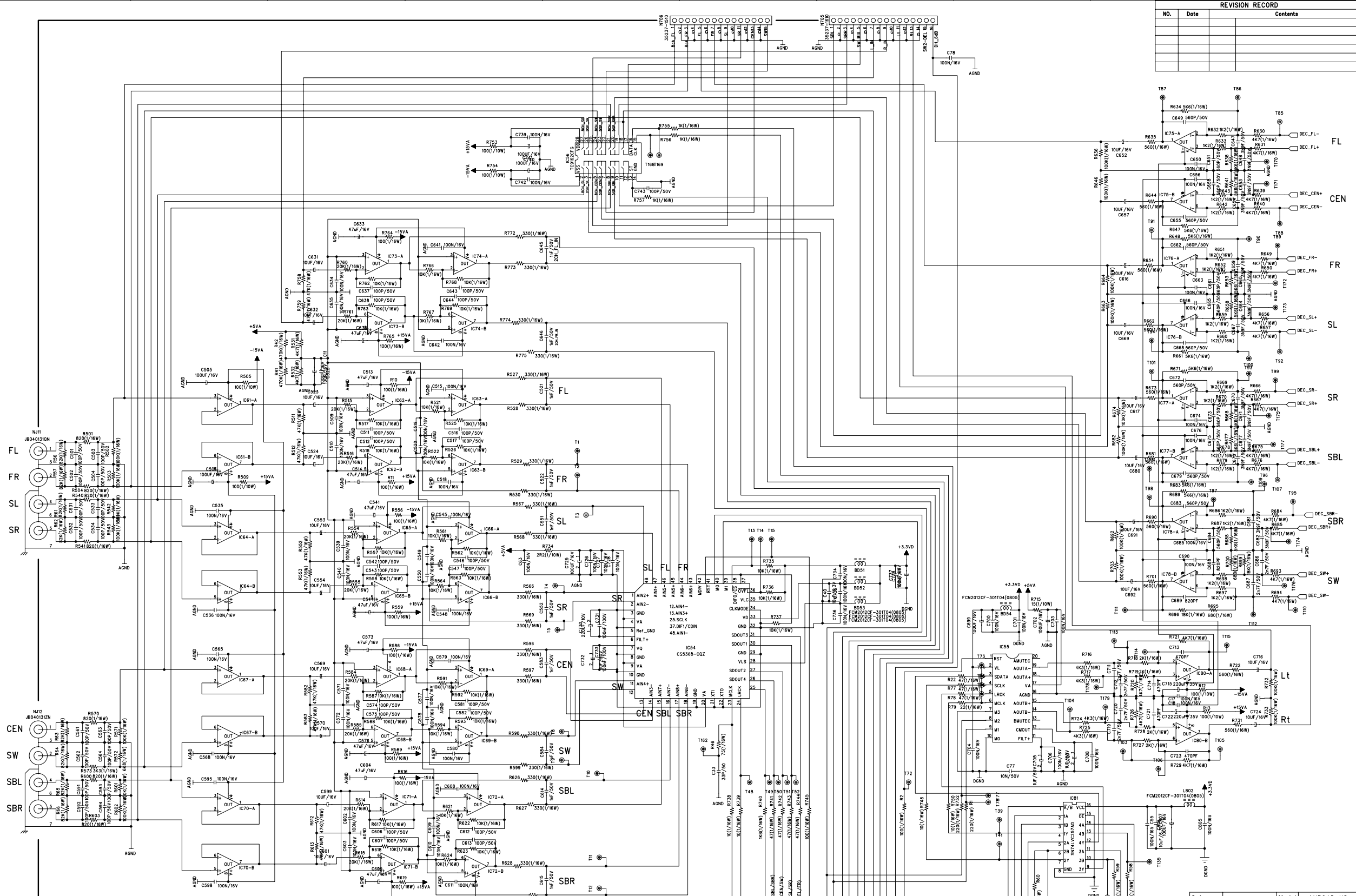

SCHEMATIC DIAGRAM
 harman kardon
 AVR645-US DSP B'D (4/5)

Category	Model	AVR645_US	
Stage	Ver.	Sheet	B'D r
MP-US		4/5	DSP
Draw	Approved	Date	Drawing No
D.H.KIM		02.May.2006	

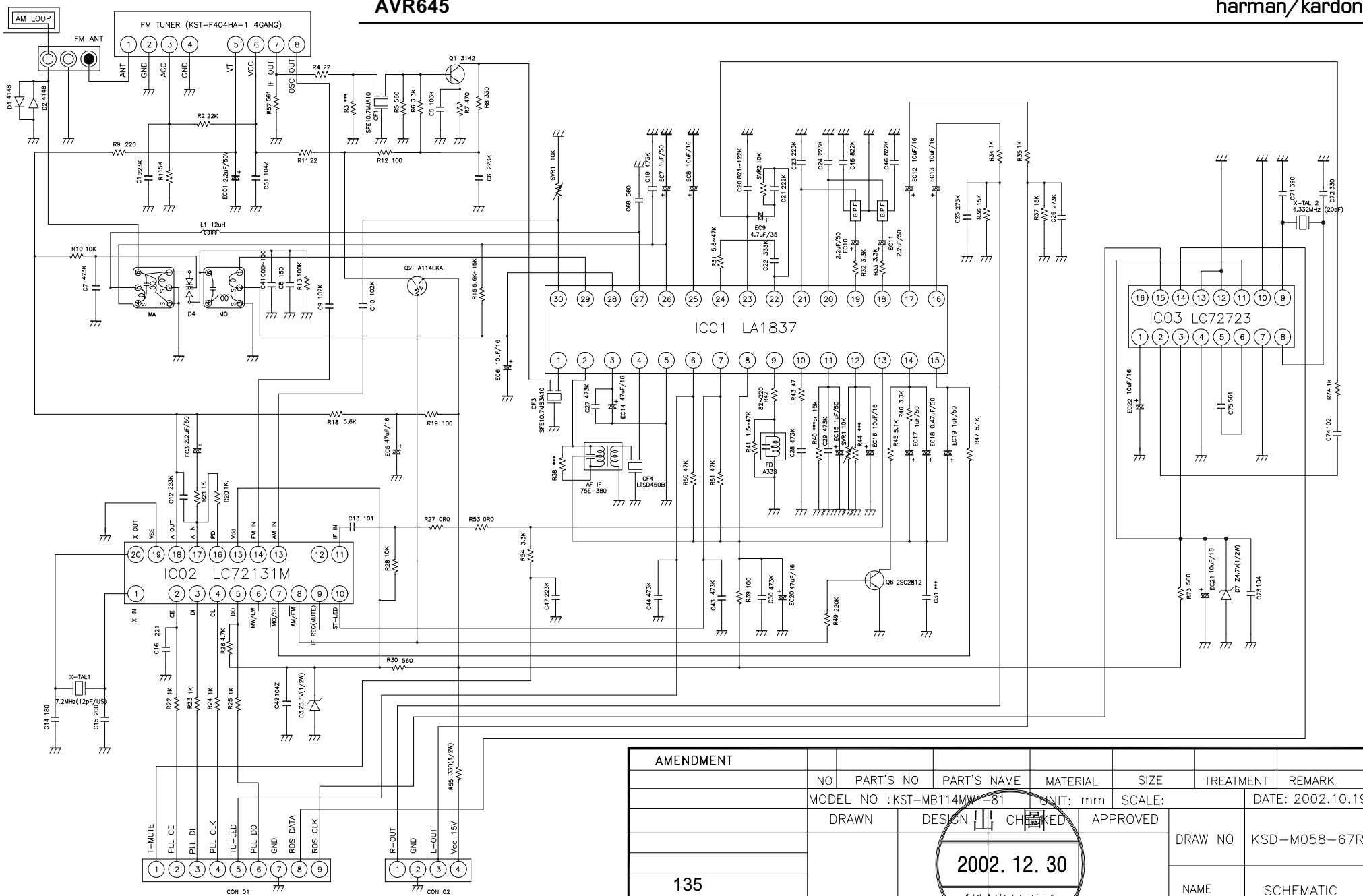

AMENDMENT		NO	PART'S NO	PART'S NAME	MATERIAL	SIZE	TREATMENT	REMARK
		MODEL NO :KST-MB114MM-81			UNIT: mm	SCALE:		DATE: 2002.10.19
		DRAWN		DESIGN	CHECKED	APPROVED		DRAW NO KSD-M058-67RS
				2002. 12. 30				NAME SCHEMATIC DIAGRAM
135				(株)光星電子				

AVR645

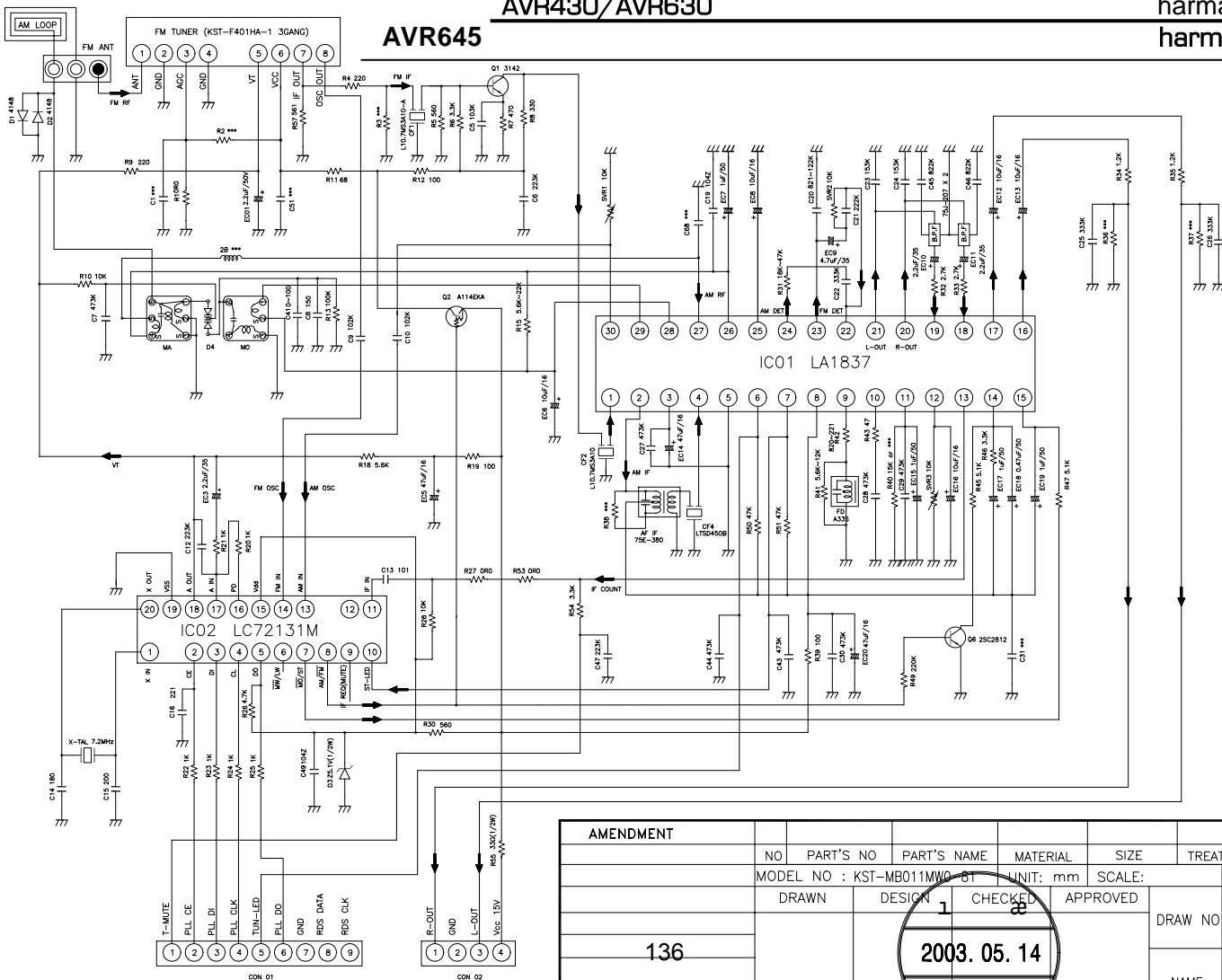

AMENDMENT											
	NO	PART'S NO	PART'S NAME	MATERIAL	SIZE	TREATMENT	REMARK				
		MODEL NO : KST-MB011MWO-8T			UNIT: mm	SCALE:		DATE: 2002.09.06			
	DRAWN	DESIGN	CHECKED	APPROVED			DRAW NO	KSD-M058-672			
			1				NAME	SCHEMATIC DIAGRAM			

2003.05.14

AVR745 MAIN AMP SCHEMATIC DIAGRAM

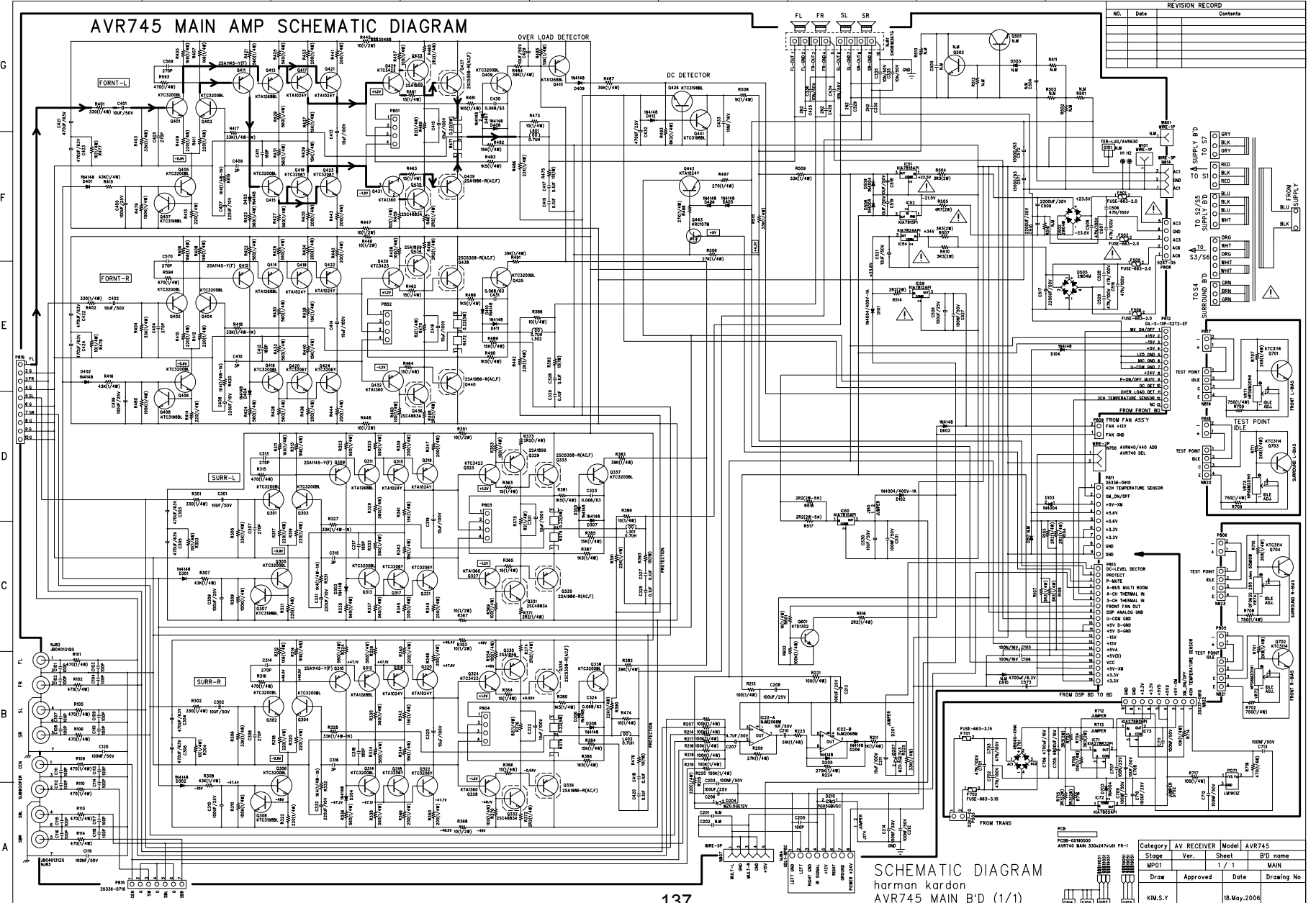

REVISION RECORD	
No.	Date

Category	AV RECEIVER	Model	AVR745
Slope	Ver.	Sheet	B'D name
MP01		1 / 1	MAIN
Draw	Approved	Date	Drawing No
KIM.S.Y		18 May 2006	

SCHEMATIC DIAGRAM
 harman kardon
 AVR745 MAIN B'D (1/1)

REVISION RECORD		
NO.	Date	Contents

SCHEMATIC DIAGRAM AVR745 CENTER SB AMP B'D

harman kardon

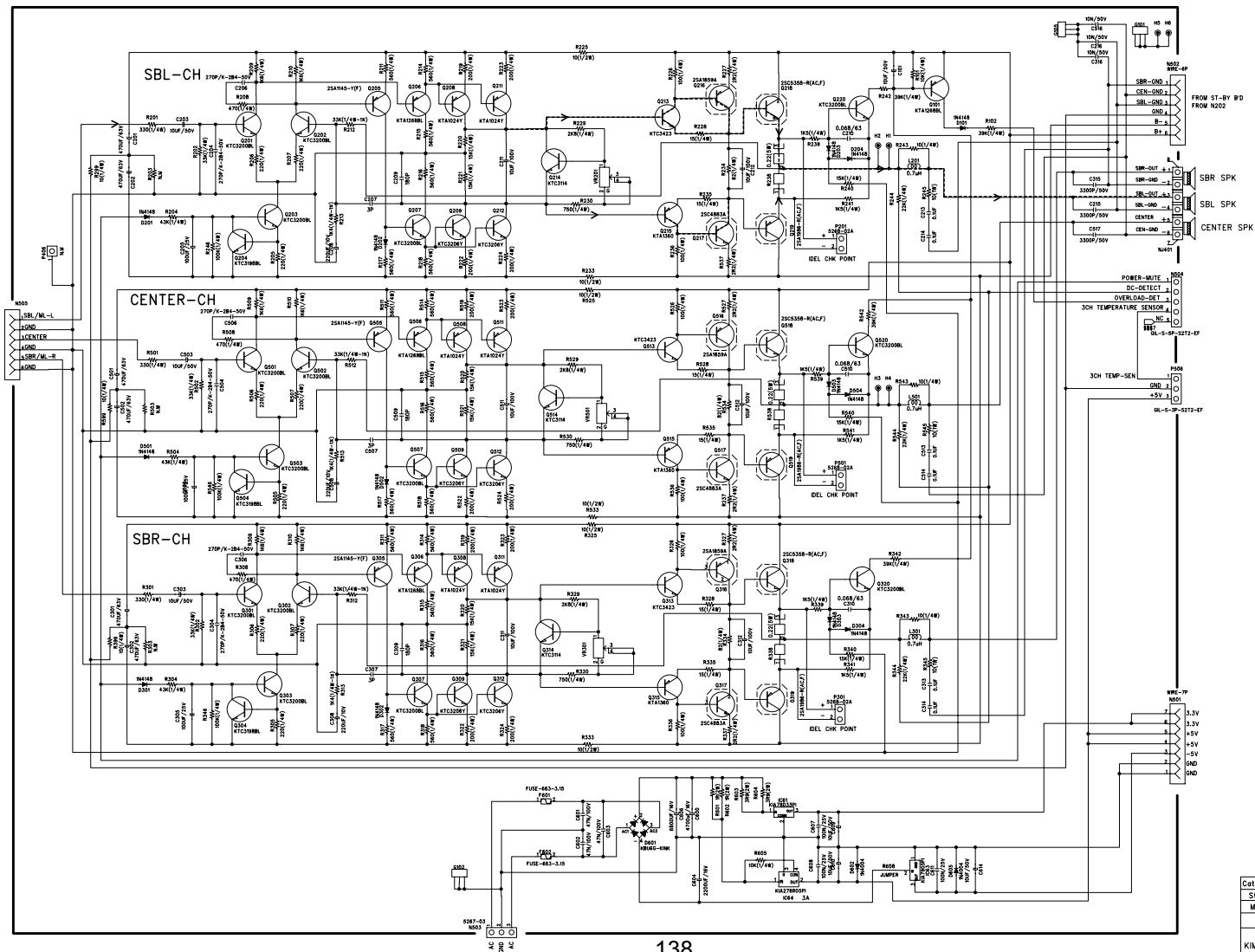

Category	AV RECEIVER	Model	AVR745
Stage	MP01	Sheet	1 / 1
Draw	Approved	Date	16.May.2006
KIM.S.Y			Drawing No

H/K AVR745/645 WIRING DIAGRAM

REVISION RECORD		
NO.	Date	Contents

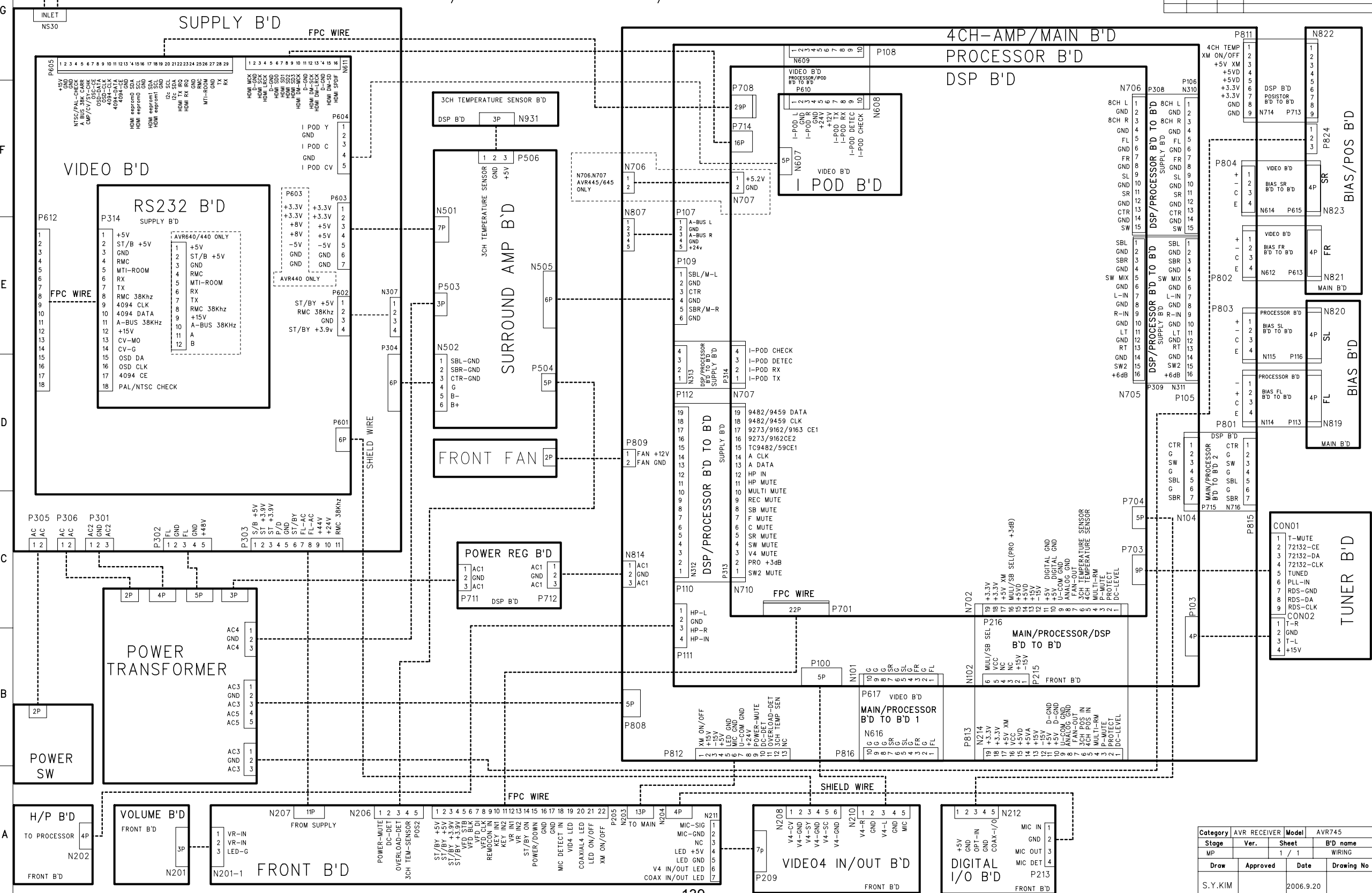

Category	AVR RECEIVER	Model	AVR745
Stage	Ver.	Sheet	B'D name
MP		1 / 1	WIRING
Draw	Approved	Date	Drawing No
S.Y.KIM		2006.9.20	